

# TM 9-6920-742-14-4

---

TECHNICAL MANUAL  
OPERATOR, UNIT, DIRECT SUPPORT,  
AND GENERAL SUPPORT MAINTENANCE MANUAL  
FOR

## ENHANCED REMOTED TARGET SYSTEM (ERETS)

INTERCONNECTING BOX,  
TARGET INTERFACE  
(NSN 5975-01-142-2797)  
(PN 9353787)

INTERCONNECTING BOX,  
HIGH POWER  
(NSN 5975-01-142-2798)  
(PN 9353786)

INTERCONNECTING BOX,  
LOW POWER  
(NSN 5975-01-142-2799)  
(PN 9341190)

DISTRIBUTION STATEMENT A - Approved for public release; distribution is unlimited.

---

HEADQUARTERS, DEPARTMENT OF THE ARMY

FEBRUARY 1997



## SAFETY SUMMARY

The following are general safety precautions that must be followed during operation and maintenance of the Interconnecting Box, Target Interface (TIU); Interconnecting Box, High Power (ICB/High Power); and Interconnecting Box, Low Power (ICB/Low Power). Personnel should become familiar with these precautions and adhere to the requirements.

### KEEP AWAY FROM LIVE CIRCUITS

Maintenance personnel must observe all safety precautions during maintenance and troubleshooting of the TIU, ICB/High Power, and ICB/Low Power. Live circuits are exposed during some maintenance and troubleshooting procedures. Capacitors within the equipment are capable of storing high voltage even after the equipment has been turned off. All capacitors should be grounded before working inside the equipment with the power turned off.

### DO NOT LIFT HEAVY OBJECTS ALONE

Always get help when lifting heavy objects. The ICB/High Power weighs approximately 50 lbs (22.7 kg). Use proper lifting procedures when removing or installing.

Refer to 21-11, First Aid for Soldiers.

### WARNING



Before working on the TIU, ICB/High Power, or ICB/Low Power, ensure that all circuit breakers have been set to OFF. Care must be taken to prevent wires shorting out to ground. Failure to do so could result in death or serious injury.

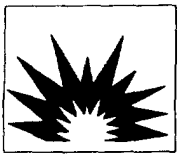

Explosion is possible and can cause personal injury and damage to equipment. Pyrotechnics are used during range operation.



Dry cleaning solvent (SD2) is toxic and flammable. Wear protective mask, goggles and gloves and use only in a well ventilated area.

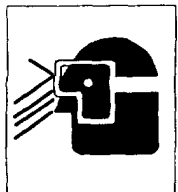

Compressed air used for cleaning purposes will not exceed 30 pounds per square inch (207 kilopascals). Use only with effective chip guarding and personal protective equipment or injury to personnel could result.

## SAFETY SUMMARY - Continued

### WARNING



ICB/HIGH Power transformer assembly weighs approximately 40 pounds (18.16 kilograms). Use proper lifting procedures when removing or installing. Failure to do so could result in serious bodily injury.

TECHNICAL MANUAL

NO. 9-6920-742- 14-4

HEADQUARTERS  
DEPARTMENT OF THE ARMY  
Washington, D.C., 13 February 1997

**TECHNICAL MANUAL**

**OPERATOR, UNIT, DIRECT SUPPORT,  
AND GENERAL SUPPORT MAINTENANCE MANUAL**

**ENHANCED REMOTED TARGET SYSTEM (ERETS)**

**INTERCONNECTING BOX, TARGET INTERFACE**

**(NSN 5975-01-142-2797) (PN 9353787)**

**INTERCONNECTING BOX, HIGH POWER**

**(NSN 5975-01-142-2798) (PN 9353786)**

**INTERCONNECTING BOX, LOW POWER**

**(NSN 5975-01-142-2799) (PN 9341190)**

**REPORTING OF ERRORS AND RECOMMENDING IMPROVEMENTS**

You can help improve this manual. If you find any mistakes or if you know of a way to improve the procedures, please let us know. Mail your letter, DA Form 2028 (Recommended Changes to Publications and Blank Forms), or DA Form 2028-2 located in the back of this manual direct to: Director, Armament and Chemical Acquisition and Logistics Activity, ATTN: AMSMC-AC-NML, Rock Island, IL 61299-7630.

**DISTRIBUTION STATEMENT A** - Approved for public release; distribution is unlimited.

**HEADQUARTERS, DEPARTMENT OF THE ARMY**

**TABLE OF CONTENTS**

	<b>Page</b>
<b>CHAPTER 1 INTRODUCTION .....</b>	1-1
<b>SECTION I GENERAL INFORMATION .....</b>	1-1
1-1 HOW TO USE THIS MANUAL .....	1-2
1-2 SCOPE .....	1-2
1-3 MAINTENANCE FORMS, LOGBOOKS, RECORDS, AND REPORTS.....	1-3

**TABLE OF CONTENTS - Continued**

		Page
<b>CHAPTER 1</b>	<b>INTRODUCTION - Continued</b>	
<b>SECTION I</b>	<b>GENERAL INFORMATION - Continued</b>	
1-4	REPORTING EQUIPMENT IMPROVEMENT RECOMMENDATIONS (EIR) .....	1-3
1-5	CORROSION PREVENTION AND CONTROL (CPC) .....	1-3
1-6	DESTRUCTION OF ARMY MATERIEL TO PREVENT ENEMY USE .....	1-4
1-7	PREPARATION FOR STORAGE OR SHIPMENT .....	1-4
1-8	NOMENCLATURE CROSS-REFERENCE LIST .....	1-4
1-9	LIST OF ABBREVIATIONS .....	1-5
<b>SECTION II</b>	<b>REPAIR PARTS; SPECIAL TOOLS; TEST, MEASUREMENT, AND DIAGNOSTIC EQUIPMENT (TMDE); AND SUPPORT EQUIPMENT ..</b>	
1-10	COMMON TOOLS AND EQUIPMENT .....	1-6
1-11	SPECIAL TOOLS, TMDE, AND SUPPORT EQUIPMENT .....	1-6
1-12	REPAIR PARTS .....	1-6
<b>SECTION III</b>	<b>EQUIPMENT DESCRIPTION .....</b>	1-6
1-13	EQUIPMENT CHARACTERISTICS, CAPABILITIES, AND FEATURES ...	1-6
1-14	LOCATION AND DESCRIPTION OF MAJOR COMPONENTS .....	1-6
1-15	EQUIPMENT DATA .....	1-8
1-16	EQUIPMENT CONFIGURATION .....	1-9
<b>SECTION IV</b>	<b>PRINCIPLES OF OPERATION .....</b>	1-10
1-17	FUNCTIONAL DESCRIPTION .....	1-10
<b>CHAPTER 2</b>	<b>OPERATING INSTRUCTIONS .....</b>	2-1
<b>SECTION I</b>	<b>DESCRIPTION AND USE OF OPERATOR'S CONTROLS AND INDICATORS .....</b>	2-1
2-1	GENERAL .....	2-1
2-2	CONTROLS AND INDICATORS .....	2-1
<b>SECTION II</b>	<b>OPERATOR PREVENTIVE MAINTENANCE CHECKS AND SERVICES (PMCS) .....</b>	2-5
2-3	GENERAL .....	2-5
<b>SECTION III</b>	<b>OPERATION UNDER USUAL CONDITIONS .....</b>	2-5
2-4	ASSEMBLY AND PREPARATION FOR USE .....	2-5
2-5	INITIAL ADJUSTMENTS, DAILY CHECKS, AND SELF-TEST .....	2-12
2-6	OPERATING PROCEDURES .....	2-12
2-7	DECALS AND INSTRUCTION PLATES .....	2-13
<b>CHAPTER 3</b>	<b>OPERATOR MAINTENANCE INSTRUCTIONS ..</b>	3-1
<b>SECTION I</b>	<b>LUBRICATION INSTRUCTIONS .....</b>	3-1
3-1	LUBRICATION .....	3-1
<b>SECTION II</b>	<b>OPERATOR TROUBLESHOOTING PROCEDURES ..</b>	3-1
	GENERAL .....	3-1
<b>SECTION 3-2</b>	<b>OPERATOR MAINTENANCE PROCEDURES ..</b>	3-1
3-3	INTRODUCTION .....	3-1
<b>CHAPTER 4</b>	<b>UNIT MAINTENANCE INSTRUCTIONS .....</b>	4-1
<b>SECTION I</b>	<b>SERVICE UPON RECEIPT .....</b>	4-1
4-1	GENERAL .....	4-1
<b>SECTION II</b>	<b>UNIT PREVENTIVE MAINTENANCE CHECKS AND SERVICES (PMCS) .....</b>	4-1
4-2	GENERAL .....	4-1
4-3	PMCS PROCEDURES .....	4-1

	Page
<b>SECTION III TROUBLESHOOTING</b> .....	4-3
4-4 TROUBLESHOOTING PROCEDURES .....	4-3
<b>SECTION IV UNIT MAINTENANCE PROCEDURES</b> .....	4-15
4-5 TIU REPLACEMENT (9353787) .....	4-15
4-6 TIU COVER ASSEMBLY REPLACEMENT (11829343-2) .....	4-17
4-7 TIU COVER ASSEMBLY GASKET REPLACEMENT (9387225 AND 11829403) .....	4-18
4-8 TIU POWER SUPPLY REPLACEMENT (9353789) .....	4-19
4-9 TIU POWER SUPPLY TERMINAL LUG REPLACEMENT (MS25036-103) .....	4-21
4-10 TIU POWER SUPPLY TERMINAL LUG REPLACEMENT (MS25036-106) .....	4-23
4-11 TIU POWER SUPPLY TERMINAL LUG REPLACEMENT (MS25036-108) .....	4-25
4-12 TIU CABLE ASSEMBLY REPLACEMENT (W107) (9363185) .....	4-27
4-13 ICB/HIGH POWER POWER BLOCK REPLACEMENT (TB5) (9353917) .....	4-28
4-14 ICB/HIGH POWER CIRCUIT BREAKER ASSEMBLY REPLACEMENT (CB1) (9354038-1) .....	4-30
4-15 ICB/HIGH POWER WIRING HARNESS REPLACEMENT (9354132) .....	4-32
4-16 ASSEMBLY OF ICB/HIGH POWER WIRING HARNESS ASSEMBLY (9354132) .....	4-34
4-17 ICB/HIGH POWER CABLE ASSEMBLY REPLACEMENT (W101-2) (9354096-2) .....	4-36
4-18 ICB/HIGH POWER CABLE ASSEMBLY REPLACEMENT (W102-2) (9354098-2) .....	4-37
4-19 ICB/LOW POWER POWER BLOCK REPLACEMENT (TB5) (9353917) ..	4-39
4-20 ICB/LOW POWER CIRCUIT BREAKER ASSEMBLY REPLACEMENT (CB1) (9354038-2) .....	4-41
4-21 ICB/LOW POWER WIRING HARNESS REPLACEMENT (9354132) .....	4-43
4-22 ASSEMBLY OF ICB/LOW POWER WIRING HARNESS ASSEMBLY (9354132) .....	4-45
4-23 ICB/LOW POWER CABLE ASSEMBLY REPLACEMENT (W101-1) (9354096-1) .....	4-47
4-24 ICB/LOW POWER CABLE ASSEMBLY REPLACEMENT (W102-1) (9354098-1) .....	4-48
4-25 ICB/LOW POWER OUTLET ASSEMBLY REPLACEMENT (CB2) (12974140) .....	4-50
<b>CHAPTER 5 DIRECT SUPPORT MAINTENANCE INSTRUCTIONS</b> .....	5-1
<b>SECTION I TROUBLESHOOTING PROCEDURES</b> .....	5-1
5-1 TROUBLESHOOTING PROCEDURES .....	5-1
<b>SECTION II DIRECT SUPPORT MAINTENANCE PROCEDURES</b> .....	5-20
5-2 GENERAL .....	5-20
5-3 TIU CONTROL LOGIC CCA REPLACEMENT (9341125) .....	5-21
5-4 TIU ETISD CCA REPLACEMENT (9387536) .....	5-22
5-5 TIU HOUSING REPLACEMENT (9353783) .....	5-24
5-6 TIU CARD HOLDER ASSEMBLY REPLACEMENT (9353816) .....	5-28
5-7 TIU CARD GUIDE FRAME REPLACEMENT (11829319) .....	5-31
5-8 TIU SUPPRESSOR ASSEMBLY REPLACEMENT (9354186-3) .....	5-32
5-9 ASSEMBLY OF TIU SUPPRESSOR ASSEMBLY (9354186-3) .....	5-34
5-10 TIU WIRING HARNESS REPLACEMENT (9353793) .....	5-35

TABLE OF CONTENTS - Continued

	Page
<b>CHAPTER 5 DIRECT SUPPORT MAINTENANCE INSTRUCTIONS (CONTINUED)</b> .....	5-1
<b>SECTION II DIRECT SUPPORT MAINTENANCE PROCEDURES (CONTINUED)</b> .....	5-20
5-11 TIU CIRCUIT BREAKER REPLACEMENT (M39019/01-321).....	5-38
5-12 TIU CONNECTOR J1 REPLACEMENT (MS3124E16-14P) .....	5-40
5-13 TIU CONNECTOR J2 REPLACEMENT (MS3474W20-39S) .....	5-42
5-14 TIU CONNECTOR J3 REPLACEMENT (MS3474W22-41 S) .....	5-44
5-15 TIU CONNECTOR J5 REPLACEMENT (MS3474W14-9P) .....	5-46
5-16 TIU CONNECTOR XA1 REPLACEMENT (9353914).....	5-48
5-17 TIU TERMINAL LUG REPLACEMENT (MS25036-106) .....	5-50
5-18 TIU TERMINAL LUG REPLACEMENT (MS25036-102) .....	5-52
5-19 TIU TERMINAL LUG REPLACEMENT (MS25036-150) .....	5-54
5-20 TIU CONNECTOR XA2 REPLACEMENT (M55302/58A70X).....	5-56
5-21 TIU WIRING HARNESS REPLACEMENT (9353958).....	5-57
5-22 ASSEMBLY OF TIU WIRING HARNESS ASSEMBLY (9353958).....	5-59
5-23 TIU CABLE 9363185 CONNECTOR P3 REPLACEMENT (11784668) ....	5-61
5-24 TIU CABLE 9363185 CONNECTOR P2 REPLACEMENT (11784662)....	5-63
5-25 ICB/HIGH POWER REPLACEMENT (9353786).....	5-65
5-26 ICB/HIGH POWER EMI FILTER REPLACEMENT (9353813).....	5-68
5-27 ICB/HIGH POWER GA TUBE ARRESTOR REPLACEMENT (9353905).....	5-70
5-28 ICB/HIGH POWER SUPPRESSION BOARD REPLACEMENT (9353854) .....	5-72
5-29 ICB/HIGH POWER CAPACITOR ASSEMBLY REPLACEMENT (M39014/02-1419) .....	5-74
5-30 ICB/HIGH POWER RECTIFIER BRACKET ASSEMBLY REPLACEMENT (9353898-1).....	5-75
5-31 ICB/HIGH POWER TRANSFORMER ASSEMBLY REPLACEMENT (9353821) .....	5-77
5-32 ICB/HIGH POWER TERMINAL LUG REPLACEMENT (MS25036-156)...	5-79
5-33 ASSEMBLY OF ICB/HIGH POWER CIRCUIT BREAKER ASSEMBLY (CBI) (9353916) .....	5-81
5-34 ICB/HIGH POWER JUMPER ASSEMBLY REPLACEMENT (9387197-1) .....	5-82
5-35 ASSEMBLY OF ICB/HIGH POWER JUMPER ASSEMBLY (9387197-1 ) .....	5-84
5-36 ICB/HIGH POWER JUMPER ASSEMBLY REPLACEMENT (9387197-2)	5-85
5-37 ASSEMBLY OF ICB/HIGH POWER JUMPER ASSEMBLY (9387197-2).....	5-87
5-38 ICB/HIGH POWER CONNECTOR P3 REPLACEMENT (MS3476W20-39P) .....	5-88
5-39 ICB/HIGH POWER TERMINAL LUG REPLACEMENT (9354176).....	5-91
5-40 ICB/HIGH POWER CONNECTOR REPLACEMENT (9353932).....	5-92
5-41 ICB/HIGH POWER CONNECTOR P2 REPLACEMENT (MS3126E16-14S) .....	5-94
5-42 ICB/HIGH POWER TERMINAL LUG REPLACEMENT (MS25036-156)...	5-97
5-43 ICB/HIGH POWER TERMINAL LUG REPLACEMENT (MS25036-149)...	5-98
5-44 ICB/LOW POWER REPLACEMENT (9341190) .....	5-100
5-45 ICB/LOWER POWER SUPPRESSION BOARD REPLACEMENT (9353854) .....	5-103
5-46 ICB/LOW POWER EMI FILTER REPLACEMENT (9353813).....	5-104



	<b>Page</b>
5-47 ICB/LOW POWER GAS TUBE ARRESTOR REPLACEMENT (9353905).....	5-106
5-48 ICB/LOW POWER CAPACITOR ASSEMBLY REPLACEMENT (M39014/02-1419).....	5-108
5-49 ICB/LOW POWER RECTIFIER ASSEMBLY REPLACEMENT (9353898-2).....	5-109
5-50 ASSEMBLY OF ICB/LOW POWER CIRCUIT BREAKER ASSEMBLY (CB1) (9353915).....	5-111
5-51 ICB/LOW POWER TRANSFORMER ASSEMBLY REPLACEMENT (9354036).....	5-112
5-52 ICB/LOW POWER TERMINAL LUG REPLACEMENT (MS25036-149).....	5-114
5-53 ICB/LOW POWER TERMINAL LUG REPLACEMENT (MS25036-153) . . .	5-116
5-54 ICB/LOW POWER JUMPER ASSEMBLY REPLACEMENT (9387197-1)	5-118
5-55 ASSEMBLY OF ICB/LOW POWER JUMPER ASSEMBLY (9387197-1) .	5-120
5-56 ICB/LOW POWER JUMPER ASSEMBLY REPLACEMENT (9387197-2)	5-122
5-57 ASSEMBLY OF ICB/LOW POWER JUMPER ASSEMBLY (9387197-2) .	5-124
5-58 ICB/LOW POWER CONNECTOR P3 REPLACEMENT (MS3476W20-39P).....	5-125
5-59 ICB/LOW POWER TERMINAL LUG REPLACEMENT (9354176).....	5-128
5-60 ICB/LOW POWER CONNECTOR REPLACEMENT (9353932) . . . . .	5-129
5-61 ICB/LOW POWER CONNECTOR P2 REPLACEMENT (MS312EI6-14S).....	5-131
5-62 ICB/LOW POWER TERMINAL LUG REPLACEMENT (MS25036-156) . . .	5-134
5-63 ICB/LOW POWER TERMINAL LUG REPLACEMENT (MS25036-149) . . .	5-135
5-64 ASSEMBLY OF ICB/LOW POWER OUTLET ASSEMBLY (12974140) . . .	5-137
 <b>APPENDIX A REFERENCES</b> .....	 A-1
A-1 SCOPE.. ..	A-1
A-2 PUBLICATION INDEXES.....	A-1
A-3 TECHNICAL PUBLICATIONS.....	A-1
A-4 FIELD MANUALS.. ..	A-1
A-5 FORMS .....	A-1
 <b>APPENDIX B MAINTENANCE ALLOCATION CHART</b> .....	 B-1
<b>SECTION I INTRODUCTION</b> .....	B-1
B-1 GENERAL .....	B-1
B-2 MAINTENANCE FUNCTIONS.....	B-2
B-3 EXPLANATION OF COLUMNS IN THE MAC, SECTION II .....	B-2
B-4 EXPLANATION OF COLUMNS IN TOOL AND TEST EQUIPMENT REQUIREMENTS, SECTION III .....	B-3
B-5 EXPLANATION OF COLUMNS IN REMARKS, SECTION IV .....	B-3
<b>SECTION II MAINTENANCE ALLOCATION CHART</b> .. ..	B-4
<b>SECTION III TOOLS AND TEST EQUIPMENT REQUIREMENTS</b> .....	B-6
<b>SECTION IV REMARKS</b> .....	B-7
 <b>APPENDIX C UNIT MAINTENANCE COMMON TOOLS AND SUPPLEMENTS AND SPECIAL TOOLS/FIXTURES LIST</b> .....	 C-1

**TABLE OF CONTENTS - Continued**

		<b>Page</b>
<b>APPENDIX D</b>	<b>EXPENDABLE AND DURABLE ITEMS LIST .....</b>	D-1
<b>SECTION I</b>	<b>INTRODUCTION .....</b>	D-1
D-1	SCOPE .....	D-1
D-2	EXPLANATION OF COLUMNS .....	D-1
<b>SECTION II</b>	<b>EXPENDABLE AND DURABLE ITEMS LIST .....</b>	D-1
<b>APPENDIX E</b>	<b>TORQUE LIMITS .....</b>	E-1
<b>SECTION I</b>	<b>INTROOUCTION .....</b>	E-1
E-1	GENERAL .....	E-1
<b>SECTION II</b>	<b>TORQUE TABLE .....</b>	E-1

**LIST OF FIGURES**

<b>Figure</b>	<b>Title</b>	<b>Page</b>
FO-1	TIU Wiring Diagram .....	FP-1/FP-2 Blank
FO-2	ICB/High Power Wiring Diagram .....	FP-3/FP-4 Blank
FO-3	ICB/Low Power Wiring Diagram .....	FP-5/FP-6 Blank
FO-4	System Wiring Diagrams .....	FP-7/FP-8 Blank

**NOTE**

This manual replaces TM 9-6920-742-14&P-8, dated 11 July 1987, and TM 9-8920-742-14&P-1, dated 7 July 1987, which have been rescinded..

# CHAPTER 1

## INTRODUCTION

### SECTION I. GENERAL INFORMATION

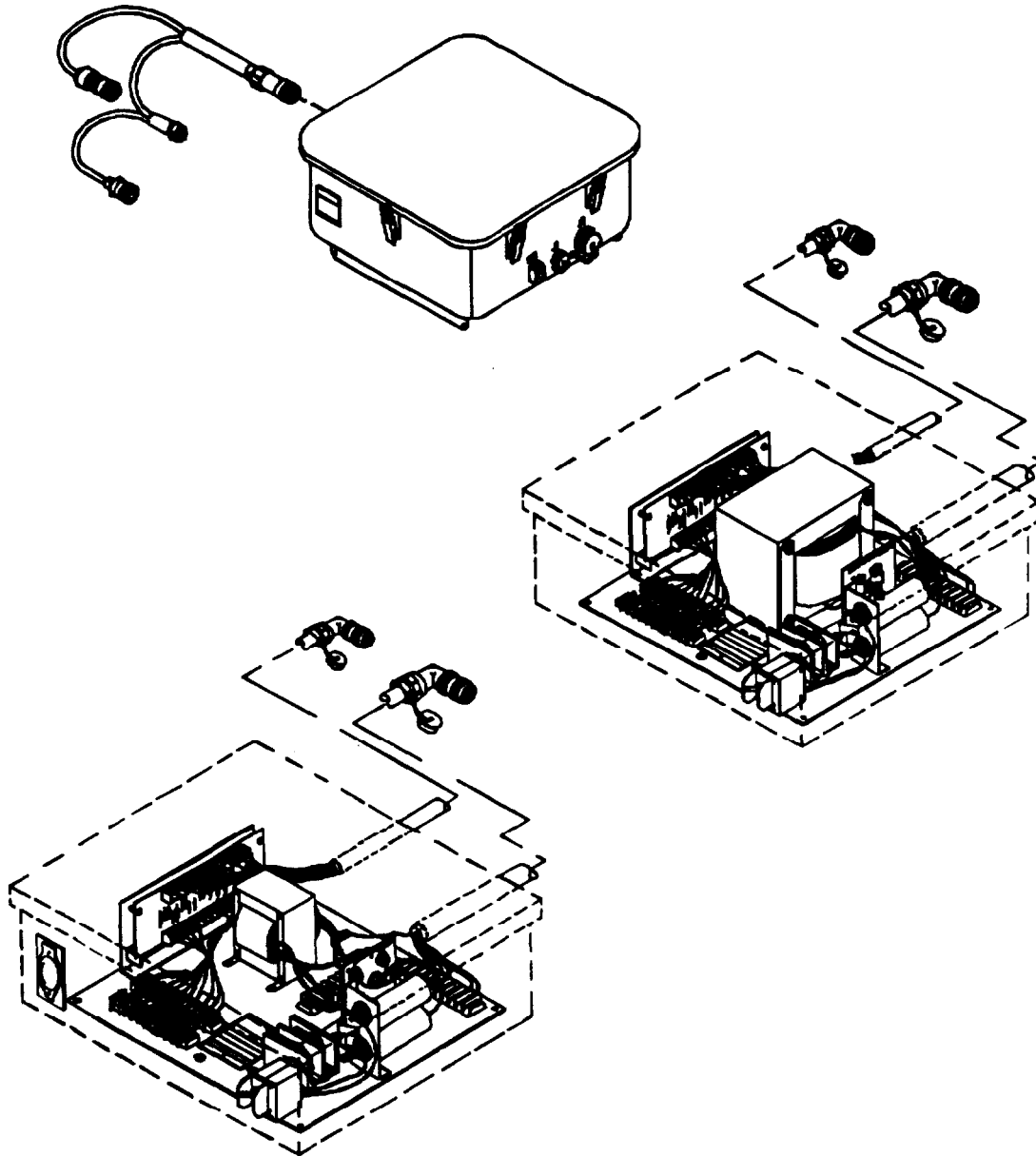

Figure 1-1. Interconnecting Box, Target Interface; Interconnecting Box, High Power; Interconnecting Box, Low Power.

## 1-1 HOW TO USE THIS MANUAL.

This manual contains operating instructions and maintenance procedures for the Interconnecting Box, Target Interface (TIU); Interconnecting Box, High Power (ICB/High Power); and Interconnecting Box, Low Power (ICB/Low Power). The manual includes five chapters, five appendixes, and an index. Chapters in this manual are divided into sections, and the sections are divided into paragraphs. Maintenance tasks are arranged in top-down breakdown order and are grouped by chapter in accordance with maintenance levels authorized to perform the tasks.

The manual follows the same presentation outlined in the table of contents. Chapter 1 provides an introduction to the TIU, ICB/High Power, and ICB/Low Power that includes equipment descriptions and principles of operation. Chapter 2 contains operating instructions for the TIU, ICB/High Power, and ICB/Low Power, as well as operator Preventive Maintenance Checks and Services (PMCS). Chapter 3 contains operator maintenance instructions. Chapter contains unit troubleshooting procedures and maintenance instructions. Chapter 4 contains direct support troubleshooting procedures and maintenance instructions.

Appendixes follow the chapters. Appendix A lists references contained in the manual. Appendix B contains the Maintenance Allocation Chart (MAC). Appendix C contains the Common Tools and Supplements and Special Tools/Fixtures List. Appendix D contains the Expendable and Durable Items List. Appendix E is a standard torque chart for common hardware. An index at the rear of the manual contains an alphabetical listing of subjects under every topic covered in the manual.

All chapter, section, paragraph, and appendix titles are listed in the table of contents. If you are looking for information on a specific subject or procedure, refer to the table of contents in the front of the manual. Find the subject or procedure in the table of contents and turn to the indicated page. If the subject or procedure is not listed in the table of contents, try looking in the Index at the rear of the manual.

## 1-2 SCOPE.

This manual presents all the information and procedures necessary to operate and maintain the TIU, ICB/High Power, and ICB/Low Power at the operator, unit, and direct support levels. Since no maintenance tasks for the TIU, ICB/High Power, or ICB/Low Power are authorized at the general support level, the manual does not contain a chapter for general support maintenance instructions.

The TIU provides power and signal to targets on the Enhanced Remoted Target System (ERETS) range. The ICB/High Power, and ICB/Low Power act as interfaces between underground data and power cables and the range equipment.

Operating and maintenance procedures allocated to the operator, unit, and direct support levels are organized in accordance with the MAC contained in appendix B. Appendix C, Common Tools and Supplements and Special Tools/Fixtures List, is not applicable. Appendix D provides a listing of expendable and durable items needed to operate and maintain the TN, ICB/High Power, and ICB/Low Power. Appendix E provides a torque limits table for common bolts and defines the difference between grades.

## 1-3 MAINTENANCE FORMS, LOGBOOKS, RECORDS, AND REPORTS.

Department of the Army forms and procedures used for equipment maintenance will be those prescribed by DA PAM 738-750, The Army Maintenance Management System. Accidents involving injury to personnel or damage to material will be reported on DA form 285 (Accident Report) in accordance with AR 385-40.

## 1-4 REPORTING EQUIPMENT IMPROVEMENT RECOMMENDATIONS.

If your TIU, ICB/High Power, or ICB/Low Power needs improvement, let us know. Send us an Equipment Improvement Recommendation (EIR). You, the user, are the only one who can tell us what you don't like about your equipment. Let us know why you don't like the design or the performance. Put it on an SF 368, Product Quality Deficiency Report (QDR). Mail it to us at: Directorr, U.S. Army Armament Research, Development and Engineering Center, ATTN: AMSTA-AC-QAW-A(R), Customer Feedback Center, Rock Island, IL 61299-7630. We will send you a reply.

## 1-5 CORROSION PREVENTION AND CONTROL (CPC).

Corrosion prevention and control (CPC) for Army material is a continuing concern. It is important that any corrosion problems with the TIU, ICB/High Power, or ICB/Low Power be reported so that the problem can be corrected and improvements can be made to prevent the problem in future items.

**a. What To Report.** While corrosion is typically associated with rusting of metals, it can also include deterioration of other materials, such as rubber and plastic. Unusual cracking, softening, swelling, or breaking of these materials may be a corrosion problem.

**b. How To Report CPC.** If a corrosion problem is identified, it can be reported using Standard Form 368, Quality Deficiency Report. Use of key words such as "corrosion," "rust," "deterioration," or "cracking," will assure that the information is identified as a CPC problem.

**c. Where To Send the Report.** This form should be submitted to: Directorr, U.S. Army Armament Research, Development and Engineering Center, ATTN: AMSTA-AC-QAW-A(R), Customer Feedback Center, Rock Island, IL 61299-7630.

### **d. Cleaning and Painting.**

- (1) Wire brush metal parts to remove rust and corrosion.

### WARNING



**Dry cleaning solvent (SD2) is toxic and flammable. Wear protective mask, goggles and gloves and use only in well ventilated area.**

- (2) Clean metal parts with dry cleaning solvent. Metal or fiber brushes may be used to apply cleaning solvent and to remove softened or dissolved material. Hand scraping with metal scrapers may be used to remove soft coatings or deposits.
- (3) Soak very oily or greasy metal parts in a tank containing dry cleaning solvent. The time parts must be in solvent varies with the type and amount of material to be removed.
- (4) Do not use solvent to clean electrical insulation, wires, cables, or wiring harnesses. Clean these parts by wiping with a damp cloth. Use a mild soap solution if necessary. Dry immediately with clean, dry cloths. Clean contact points with flint abrasive paper and dust thoroughly after cleaning.

**1-5 CORROSION PREVENTION AND CONTROL (CPC) (CONTINUED).**

- (5) Do not use dry cleaning solvent to clean rubber parts. Clean rubber parts by washing with a mild solution of soap and water.

**WARNING**

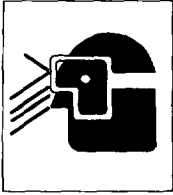

**Compressed air used for cleaning purposes will not exceed 30 pounds per square inch (207 kilopascals). Use only with effective chip guarding and personal protective equipment or injury to personnel could result.**

- (6) Dry parts by blowing with low-pressure compressed air or wiping with lint-free cloths.
- (7) Paint metal surfaces after repaired as required. Sand and paint damaged areas. Apply one coat of rust inhibitor primer. Allow primer to dry for 30 minutes minimum before applying enamel. Paint with enamel to match existing color.

**1-6 DESTRUCTION OF ARMY MATERIEL TO PREVENT ENEMY USE.**

Destruction of Army materiel to prevent enemy use shall be in accordance with TM 750-244-3.

**1-7 PREPARATION FOR STORAGE OR SHIPMENT.**

Refer to AR 750-1 for requirements for administrative storage.

**1-8 NOMENCLATURE CROSS-REFERENCE LIST.**

**Table 1-1. Nomenclature Cross-Reference List.**

OFFICIAL NOMENCLATURE	COMMON NAME
Adapter, Power Supply	Range Control Station Adapter (RCS Adapter)
Console, Target Training Set - ERETS (Armor)	Range Control Station, Enhanced Remoted Target System, Armor (RCWERETS Armor)
Console, Target Training Set - ERETS (Infantry)	Range Control Station, Enhanced Remoted Target System, Infantry (RCS/ERETS Infantry)
Interconnecting Box, High Power	Interconnecting Box (ICB)
Interconnecting Box, Low Power	Interconnecting Box (ICB)
Interconnecting Box, Target Interface	Target Interface Unit (TIU)

Table 1-1. Nomenclature Cross-Reference List (Continued).

OFFICIAL NOMENCLATURE	COMMON NAME
Simulator, Gunfire	Armor Target Kill Simulator (ATKS)Target Kill Simulator (TKS)Gunfire Simulator Device (GUFS)
Simulator, Muzzle Flash, Small Arms	Muzzle Flash Simulator (MFS)
Simulator, Sound, Small Arms	Rifle Fire Simulator (RFS)Small Arms Sound Simulator (SASS)
Target Holding Mechanism, Tank Gunnery	Target Holding Mechanism, Tank Gunnery (THM/TG)Automatic Tank Target System (ATTS)
Target Holding Set, Training	Infantry Target Mechanism (ITM)
Track System, Target Training Set - Armor	Armor Moving Target Carrier (AMTC)
Track System, Target Training Set - Infantry	Infantry Moving Target Carrier (IMTC)

**1-9 LIST OF ABBREVIATIONS.**

The following list contains the acronyms and abbreviations used throughout the manual and in conjunction with the range system.

AMTC	Armor Moving Target Carrier
CCA	Circuit Card Assembly
ERETS	Enhanced Remoted Target System
GUFS	Gunfire Simulator
ICB	Interconnecting Box
ILTEM	Improved Lift Target Elevating Mechanism
IMTC	Infantry Moving Target Carrier
ITM	Infantry Target Mechanism
RCS	Range Control Station
THMITG	Target Holding Mechanism, Tank Gunnery
TIU	Target Interface Unit
TTA	Tank Target Assembly
SASS	Small Arms Sound Simulator

## **SECTION II. REPAIR PARTS; SPECIAL TOOLS; TEST, MEASUREMENT, AND DIAGNOSTIC EQUIPMENT (TMDE); AND SUPPORT EQUIPMENT**

### **1-10 COMMON TOOLS AND EQUIPMENT.**

For authorized common tools and equipment, refer to the Table of Distribution and Allowances (TDA) applicable to your unit.

### **1-11 SPECIAL TOOLS, TMDE, AND SUPPORT EQUIPMENT.**

Refer to appendix B, Maintenance Allocation Chart, and TM 9-6920-742-24P-4, Repair Parts and Special Tools List, for any special tools, TMDE, and support equipment required to maintain the TIU, ICB/High Power, or ICB/Low Power.

### **1-12 REPAIR PARTS.**

Repair parts are listed and illustrated in the Repair Parts and Special Tools List, TM 9-6920-742-24P-4.

## **SECTION III. EQUIPMENT DESCRIPTION**

### **1-13 EQUIPMENT CHARACTERISTICS, CAPABILITIES, AND FEATURES.**

The TIU is an electrical device which receives encoded target control data from the RCS and decodes it into control signals used by the THM/TG, Gunfire Simulator, and Track System, Target Training Set - Armor. The TIU provides a limited power source to recharge the battery in the THM/TG. The TIU also encodes and sends status and hit information to the RCS.

The ICB/High Power, and ICB/Low Power provide interfaces between the underground data and power cables and the equipment. They provide the following: (1) 24 vdc power for use by the targets; (2) power and data cable transient protection; (3) circuit breaker electrical protection; and (4) 240 vat for use by the THM/TG battery eliminator assembly (ICB/Low Power only). The ICB/High Power is used exclusively with the IMTC while the ICB/Low Power is used for all other configurations.

### **1-14 LOCATION AND DESCRIPTION OF MAJOR COMPONENTS.**

The following subparagraphs give a brief description of the major components of the TIU, ICB/High Power, and ICB/Low Power. Refer to figure 1-2 for the location.

#### **a. Interconnecting Box, Target Interface.**

(1) **Housing.** The TIU housing provides a watertight enclosure for the components as well as connections for various interfacing cables.

(2) **W107 Cable Assembly.** The W107 cable assembly provides an interface between TIU connector J3 and the THM/TG control assembly and proximity switch cable.



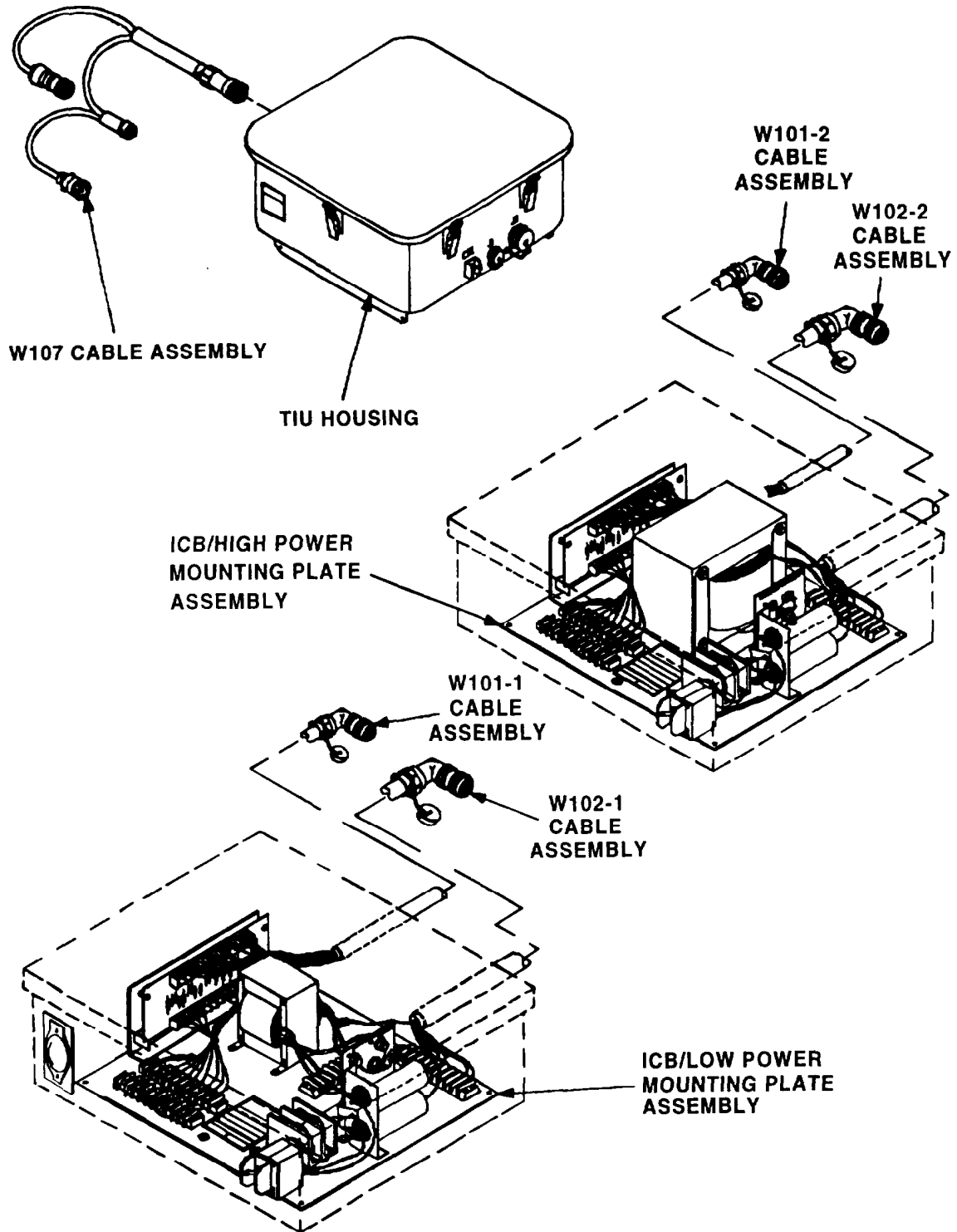

Figure 1-2. Location and Description of Major Components.

**b. Interconnecting Box, High Power.**

(1) **Mounting Plate Assembly.** The mounting plate assembly provides a platform on which most of the ICB/High Power components are secured. It also provides terminal board connections for various interfacing cables.

(2) **W101-2 Cable Assembly.** The W101-2 cable assembly provides a data interface between the ICB/High Power and IMTC connector J2.

(3) **W102-2 Cable Assembly.** The W102-2 cable assembly provides a power interface between the ICB/High Power and IMTC connector J1.

**c. Interconnecting Box, Low Power.**

(1) **Mounting Plate Assembly.** The mounting plate assembly provides a platform on which most of the ICB/High Power components are secured. It also provides terminal board connections for various interfacing cables.

(2) **W101-1 Cable Assembly.** The W101-1 cable assembly provides a data interface between the ICB/Low Power and TIU connector J2 or ITM connector J3.

(3) **W102-1 Cable Assembly.** The W102-1 cable assembly provides a power interface between the ICB/Low Power and TIU connector J1 or ITM connector J1 .

**1-15 EQUIPMENT DATA.**

**Table 1-2. Equipment Data.**

<b>PHYSICAL CHARACTERISTICS</b>	
<b>TIU:</b>	
Weight	approximately 20 lbs (9.08 kg)
Height	8 in (20.32 cm)
Length	16 in (40.64 cm)
Width	16 in (40.64 cm)
<b>ICB/High Power:</b>	
Weight	approximately 50 lbs (22.7 kg)
Height	6.5 in (16.51 cm)
Length	16 in (40.64 cm)
Width	14 in (35.56 cm)
<b>ICB/Low Power:</b>	
Weight	approximately 15 lbs (6.81 kg)
Height	6.5 in (16.51 cm)
Length	16 in (40.64 cm)
Width	14 in (35.56 cm)

**Table 1-2. Equipment Data (Continued).**

<b>ENVIRONMENTAL STANDARDS</b>	
<b>TIU:</b>	
Temperature	+5 to +125 °F (-15 to +52 °C)
Relative Humidity	5 to 95 percent
Low Pressure Limit	16.9 in Hg/15,000 ft altitude (42.93 cm Hg/4,575 m altitude)
<b>ICB/High Power:</b>	
Temperature	+5 to +125 °F (-15 to +52 °C)
Relative Humidity	5 to 95 percent
Low Pressure Limit	16.9 in Hg/15,000 ft altitude (42.93 cm Hg/4,575 m altitude)
<b>ICB/Low Power:</b>	
Temperature	+5 to +125 °F (-15 to +52 °C)
Relative Humidity	5 to 95 percent
Low Pressure Limit	16.9 in Hg/15,000 ft altitude (42.93 cm Hg/4,575 m altitude)
<b>ELECTRICAL CHARACTERISTICS</b>	
<b>TIU:</b>	
Input Voltage	24 ±1 .5 vdc
Input Current	3 A/72 W
Output Voltage	24 ±1.5 vdc, 12 ±1.5 vdc
<b>ICB/High Power:</b>	
Input Voltage	240 ±5 vac
Output Voltage	240 ±5 vac, 24 ±1.5 vdc
Minimum Output Current	50±1 A
<b>ICB/Low Power:</b>	
Input Voltage	240 ±5 vac
Output Voltage	240 ±5 vac, 24 ±1.5 vdc
Minimum Output Current	15±1 A

**1-16 EQUIPMENT CONFIGURATION.**

All ERETS ranges are constructed differently. The configuration will depend upon design, climate, terrain, and mission. This technical manual was developed to the technical data packages. There are other configurations of the TIU, ICB/High Power, and ICB/Low Power in the field. The user/maintainer must consider the differences and make allowances between the specific unit and the manual.

## SECTION IV. PRINCIPLES OF OPERATION

### 1-17 FUNCTIONAL DESCRIPTION.

a. **General.** The TIU, ICB/High Power, and ICB/Low Power are designed to operate with the ERETS RCS computer. There are two types of targets used with the TIU: the Target Holding Mechanism, Tank Gunnery (THM/TG), a stationary target with up/down capabilities and the Armor Moving Target Carrier (AMTC), a moving armor target.

b. **TIU.** The TIU is used to decode commands from the ERETS RCS and provides the necessary control signals for the AMTC, THM/TG and the GUFs. When a frame of data is addressed to this unit, it is held in the input data register and used to command the target controlled by this unit. The TIU contains a power supply, a control logic board CCA, and a signal distributor board CCA. The power source for the TIU is the ICB Low Power which supplies 24 +1.5 vdc through connector J1 to circuit breaker CBI .

The TIU makes the hit count and up/down-attack/retreat limit status available to the ERETS RCS computer and also provides the necessary power for charging the THM/TG battery.

The TIU interfaces with the various components by means of cables that connect to five box-mounted connectors (see FO1).

The TIU operates on unfiltered, full wave rectified dc power. The rectifier is fed by an ac signal of 28 ±3 vac (RMS) and delivers five amps of current.

Communication between the TIU and the RCS is accomplished via four pairs of wires. The scheme consists of a clock signal, a 32-bit data word, and a 32-bit status word. The fourth wire pair is used for status power.

The TIU responds to command data and sends status back to the RCS only if the address in the command word corresponds to the TIU address. The TIU address is selectable by a nine-position switch on the control logic card inside the TIU. Communication protocol is such that the TIU responds to the command word, if addresses correspond, and send the current status during the same clock train. Status determining proper response to the present command word is transmitted from the TIU to the RCS on the next clock train

c. **ICB/High Power and ICB/Low Power.** The ICBs are used as tie-in points for 240 vac power and the RCS data lines to the targets, The RCS provides +24-volt switched output and noise-suppressed data lines for computer communication. Each separately addressable target system has its own interconnecting box. The ICB/High Power supplies the data and higher power requirements of the IMTC while the ICB/Low Power supplies the data and power requirements for all other applications.

The main power cables to the ICBs contain four wires: two wires provide 240 vac, one is the earth ground, and one is a return line which is not used. The power wires are attached to TB5 terminals 1 and 2, and go back out of the ICBs for routing to the next box. From TB5, the power is routed to CB1. When in the ON position, 240 vac is applied through filters FL1 and FL2 to the primary of transformer T1 . T1's secondary windings are routed to the rectifier assembly where power is rectified to +24 vdc.

Data, clock, status, and status power signals enter the ICBs and are attached to TB1 . From this point, data wires also exit the ICBs and go to the next box. Data, data return, clock, and clock return lines are wired from TB8 to TB7, pin to pin, where cable W-101 attaches to route the signals to the target system control unit.

Status power, +12 vdc, and its return are wired from TB8 to TB7, pin to pin, where cable W-101 attaches to route the signals to the target system control unit.

Status lines which are wired to terminals 1 and 2 of TB8, are capacitance-coupled to terminals 6 and 7 where cable W-101 is attached. Eight resistors, one per line, R1 through R8, serve to isolate the lane data cable from the suppressor circuits in each ICB.



## CHAPTER 2

### OPERATING INSTRUCTIONS

#### SECTION I. DESCRIPTION AND USE OF OPERATOR'S CONTROLS AND INDICATORS

##### **2-1 GENERAL.**

This section shows the location and describes the function and use of the controls and indicators used on the Interconnecting Box, Target Interface (TIU); Interconnecting Box, High Power (ICB/High Power); and Interconnecting Box, Low Power (ICB/Low Power). It provides preliminary procedures which are required to place the unit in service.

##### **2-2 CONTROLS AND INDICATORS.**

Controls and indicators on the TIU are described in the table 2-1 and illustrated in figure 2-1. The controls and indicators for the ICB/High Power are described in table 2-2 and illustrated in figure 2-2. The controls and indicators for the ICB/Low Power are described in table 2-3 and illustrated in figure 2-3.

**Table 2-1. TIU Controls and Indicators.**

KEY	CONTROL OR INDICATOR	FUNCTION
1	Circuit Breaker CB1	Removes all power to the TIU when in the POWER OFF position. In the POWER ON position, it applies 24 vdc power to the TIU and provides overload protection.
2	Pressure Relief Valve	When pressed, equalizes internal pressure in unit.
3	Address Switch	Establishes an address code for TIU. TIU only responds to commands from Target Training Set Console (RCS) - Enhanced Remoted Target System (ERETS) addressed with same code.

2-2 CONTROLS AND INDICATORS (CONTINUED).

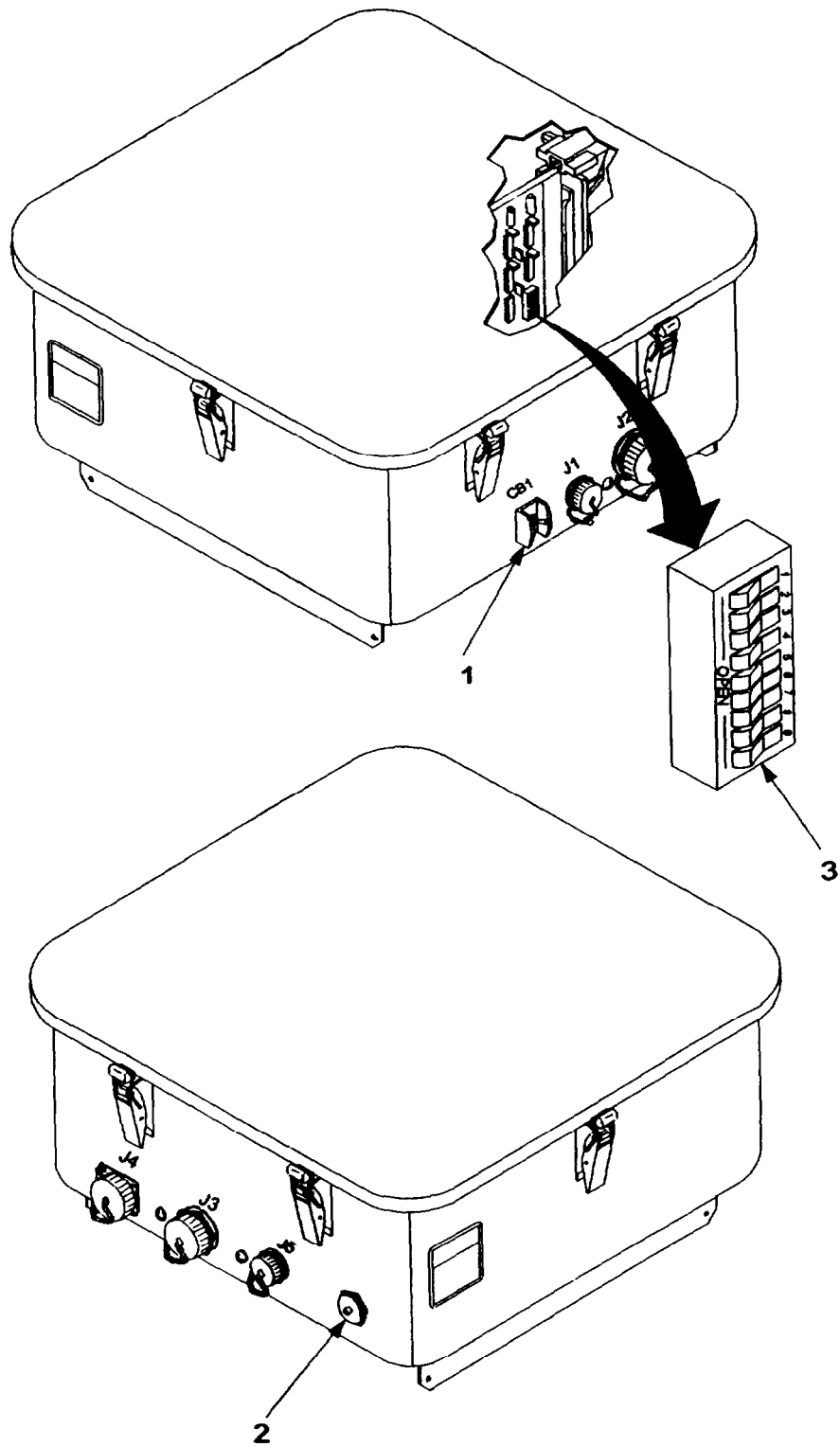

Figure 2-1. TIU Controls and Indicators.



Table 2-2. ICB/High Power Controls and Indicators.

KEY	CONTROL OR INDICATOR	FUNCTION
1	Circuit Breaker CB1	Removes all power to the ICB/High Power in the POWER OFF position. In the POWER ON position, it applies 240 vac power to the ICB/High Power and provides overload protection.

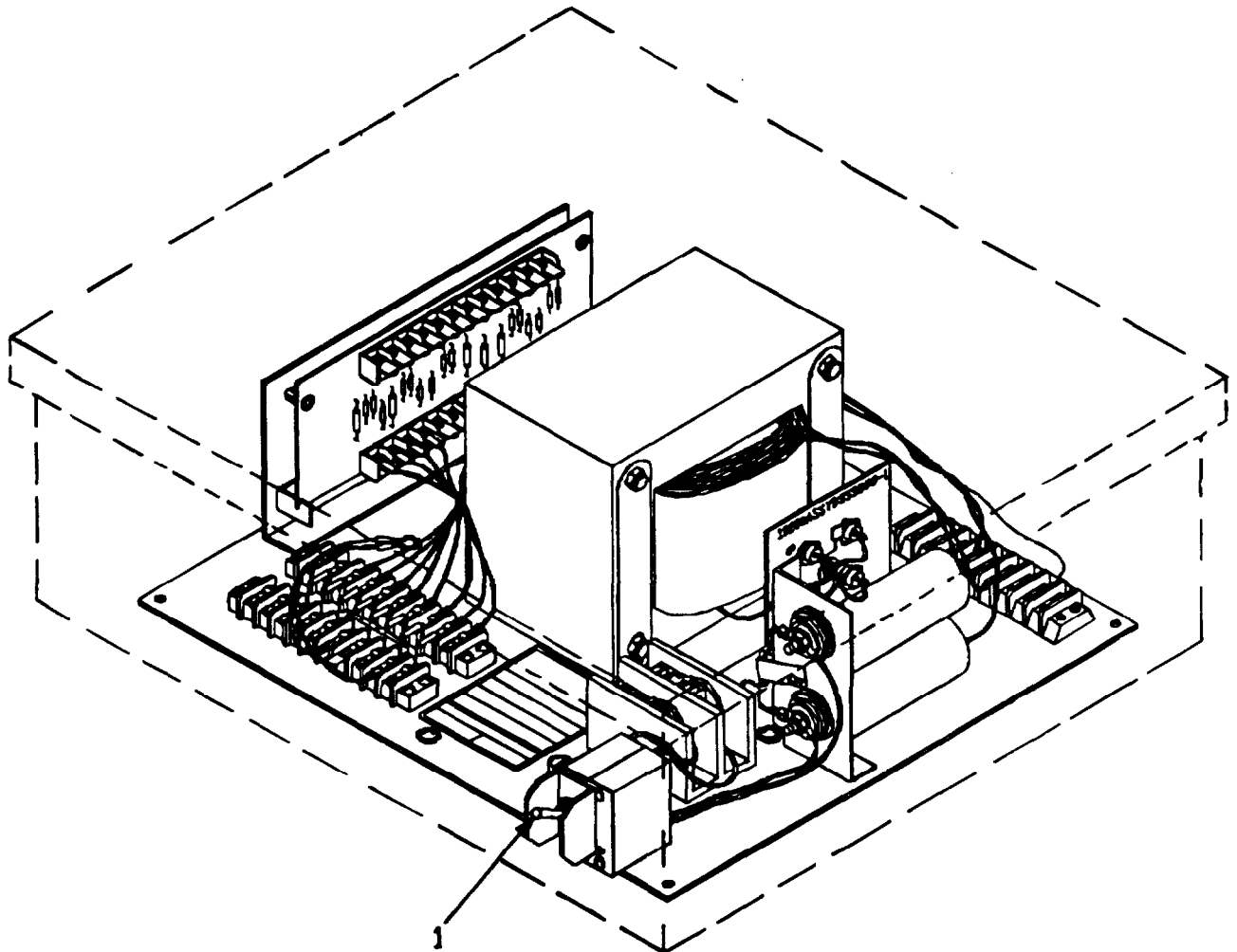

Figure 2-2. ICB/High Power Controls and Indicators.

Table 2-3. ICB/Low Power Controls and Indicators.

KEY	CONTROL OR INDICATOR	FUNCTION
1	Circuit Breaker CB1	Removes all power to the ICB/Low Power in the POWER OFF position. In the POWER ON position it applies 240 vac to the ICB/Low Power and provides' overload protection.
2	Outlet assembly	Provides an outlet for 240 vac,

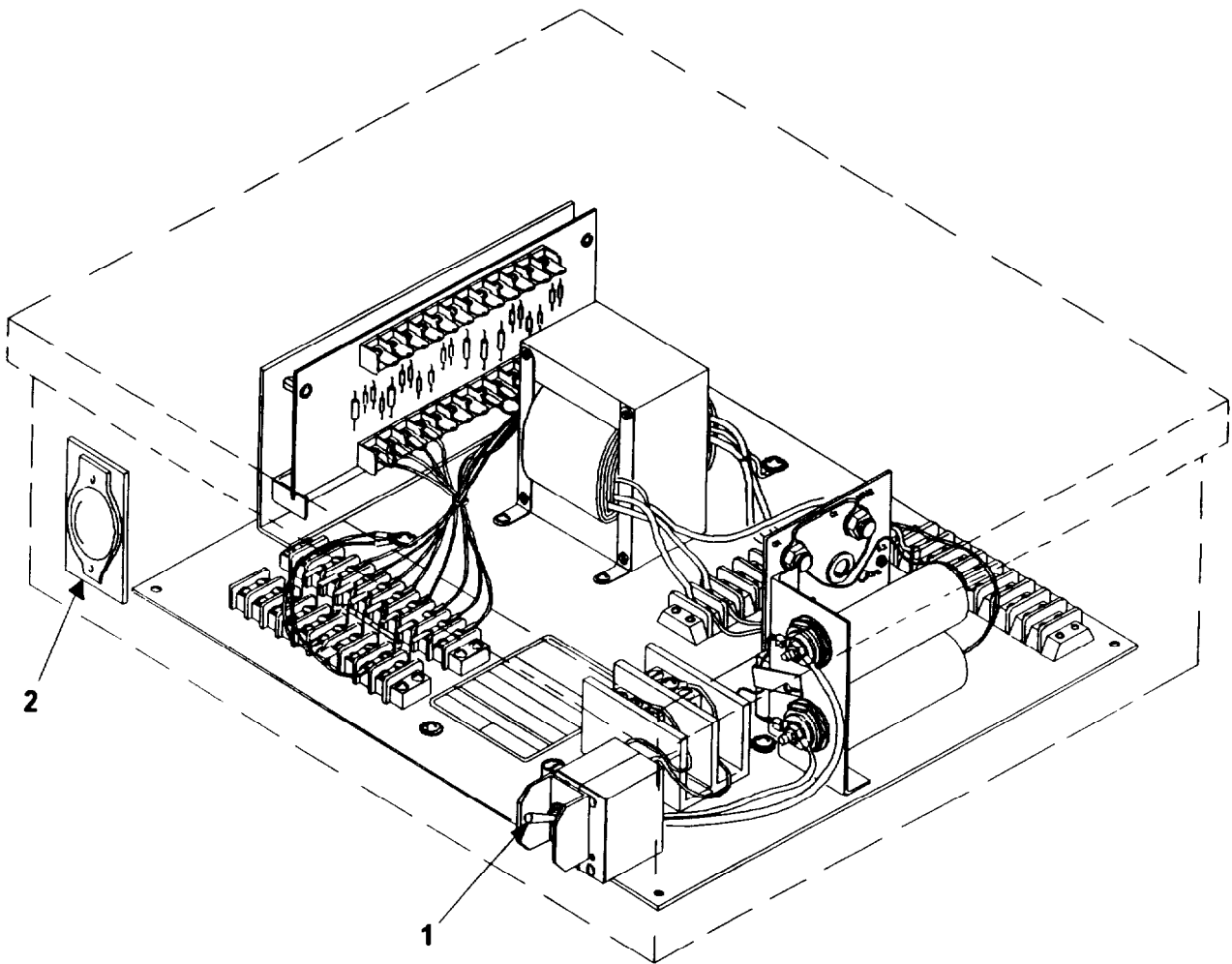

Figure 2-3. ICB/Low Power Controls and Indicators.

## SECTION II. OPERATOR PREVENTIVE MAINTENANCE CHECKS AND SERVICES (PMCS)

### 2-3 GENERAL.

No PMCS is performed by the operator for the TIU; ICB/High Power; or ICB/Low Power. All PMCS procedures are performed by unit maintenance.

## SECTION III. OPERATION UNDER USUAL CONDITIONS

### 2-4 ASSEMBLY AND PREPARATION FOR USE.

The TIU, ICB/High Power, and ICB/Low Power are used with the range control station ERETS. The following procedures describe the steps necessary to prepare the TIU, ICB/High Power, and ICB/Low Power for operation.

a. **Assembly and Preparation of TIU.** To assemble and prepare the TIU for operation, refer to figure 2-4 and FO-1 and perform the following steps:

#### WARNING



**Disarm, then disconnect the gunfire simulator (GUFs) from TIU connector J4. The GUFs must be disconnected before performing the next steps.**

- (1) Place ICB/Low Power CB1 in the POWER OFF position.
- (2) Place TIU CB1 (1) in the POWER OFF position.
- (3) Install cable assembly W101-1P3 (2) from ICB/Low Power to TIU connector J2.
- (4) Install cable assembly W102-1P2 (3) from ICB/Low Power to TIU connector J1.
- (5) Install cable assembly W107 P1 to TIU connector J3 (4) (THM/TG only).
- (6) Install cable assembly W11 P1 to TIU connector J3 (4) (AMTC only).

#### NOTE

**For loading and operation of the GUFs, refer to TM9-6920-742-14-2.**

- (7) Position gunfire simulator in protected area. Clear brush and other flammable material away from GUFs. Connect the GUFs to TIU connector J4 (5).
- (8) Place ICB/Low Power CB1 in the POWER ON position.
- (9) Place TIU CB1 in the POWER ON position.

2-4 ASSEMBLY AND PREPARATION FOR USE (CONTINUED).

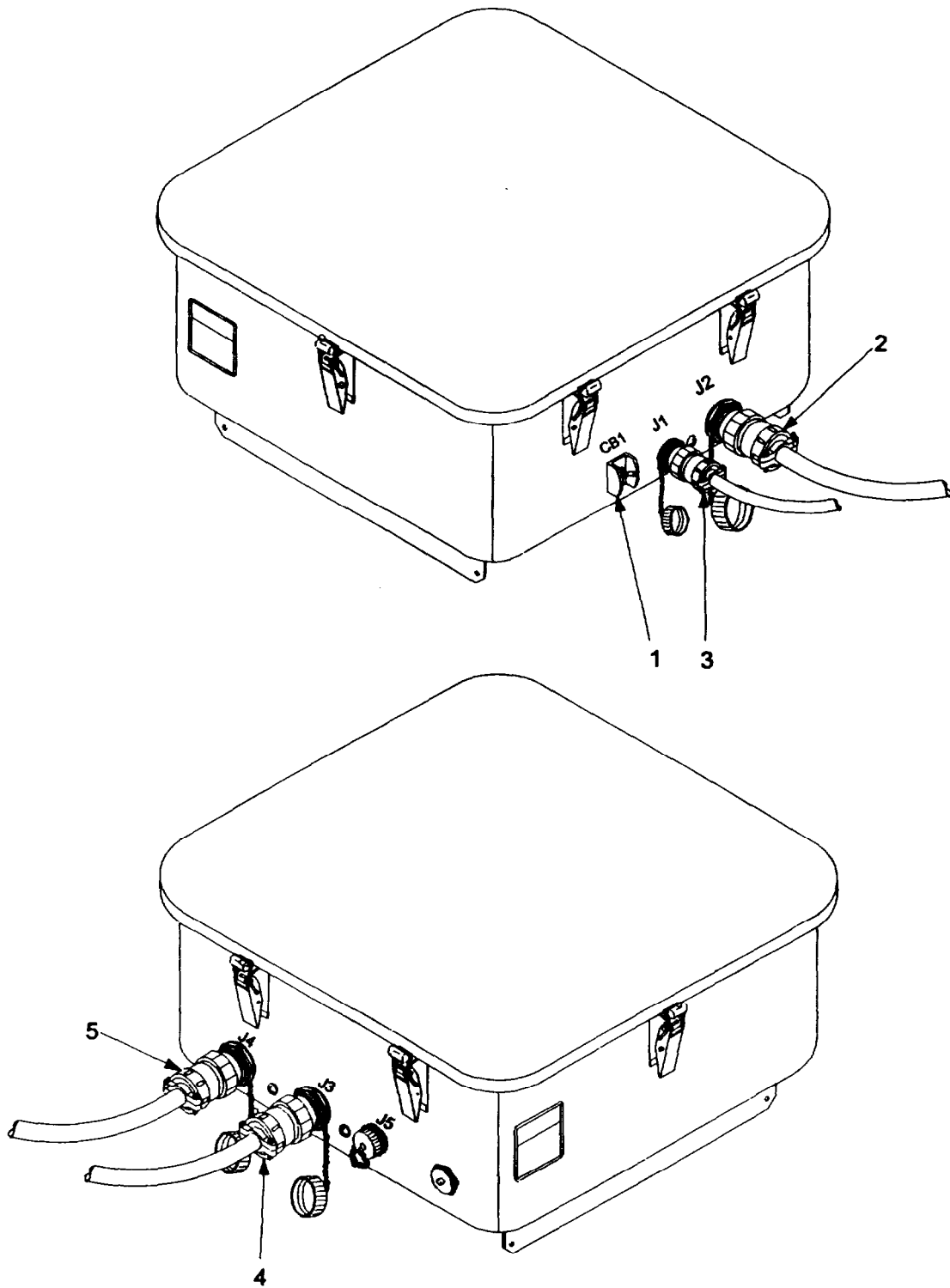
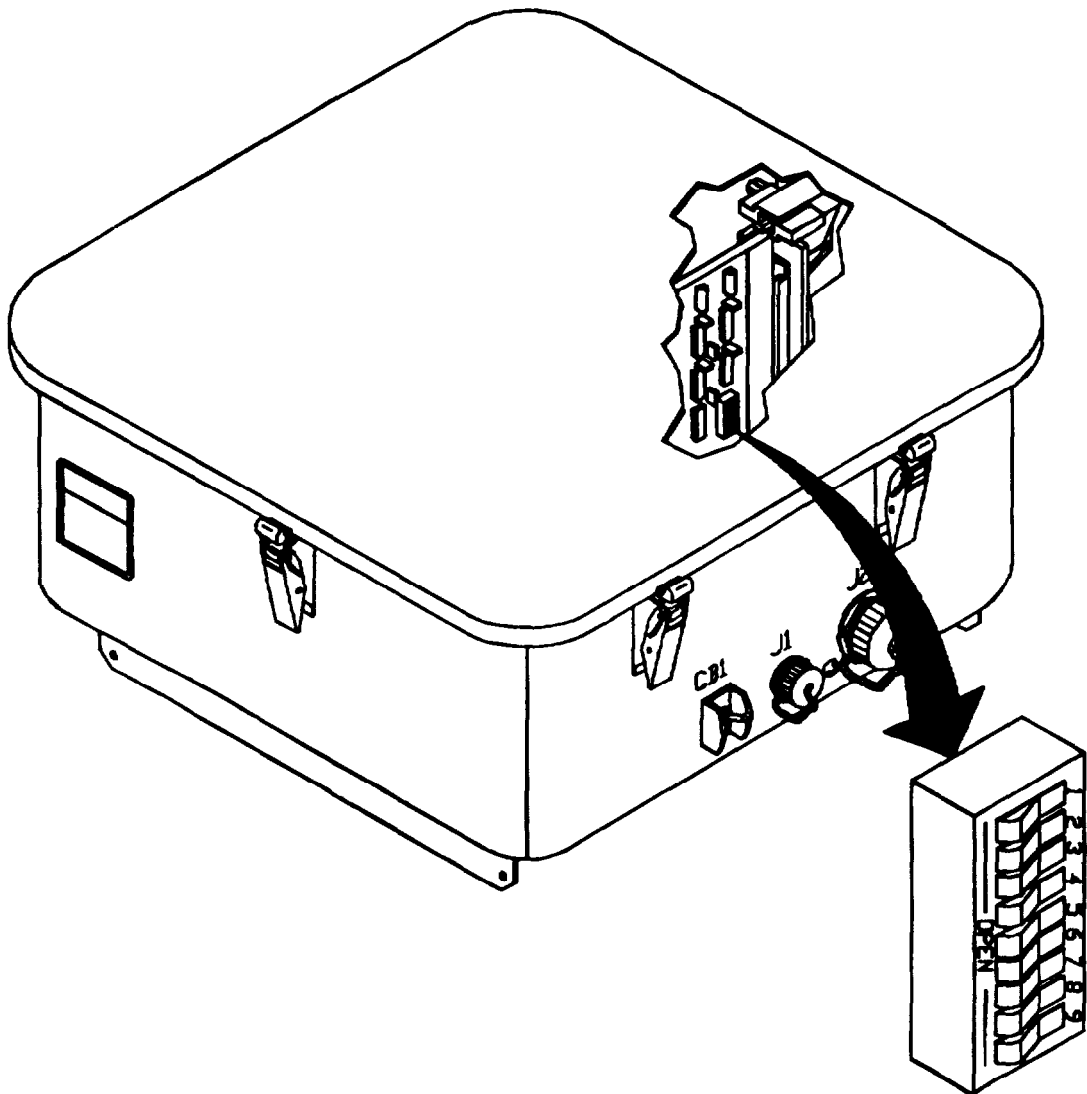

Figure 2-4. Preparation for Use of the TIU.

b. **Setting the Binary Code on the TIU Address Switch.** Each individual TIU on a ERETS range is assigned a specific number or target address. The address of the individual TIU is determined by the setting on the address switch located on the control logic CCA (reference figure 2-1). The target address assigned to the TIU is based on a binary numbering system. A total of nine switches on the address switch can be positioned in "0" and "1" combinations that represent a binary code. The binary code is a combination of binary numbers that are used to identify target numbers 1 through 511.

Binary numbers are obtained from a method of counting that compounds the value of each successive numeral. Table 2-4 shows the binary number that is represented by each one of the nine switches and the real number to which it is equal.



**2-4 ASSEMBLY AND PREPARATION FOR USE (CONTINUED).**

Switch numbers "1" through "9" are used to represent binary numbers "1" through "9." And binary numbers "1" through "9" are equal to the real numbers listed in table 2-4. Various combinations of these nine binary numbers can be used to create 511 different target addresses.

**Table 2-4. Binary Numbers on Address Switch.**

BINARY NUMBER (ADDRESS SWITCH NUMBER)	EQUALS REAL NUMBER
1	1
2	2
3	4
4	8
5	16
6	32
7	64
8	128
9	256

Address code settings are determined by selecting the correct combination of binary numbers whose real number equivalents, when added together, will equal the target number. For each binary number that is selected, the corresponding switch on the address switch must be set to the "1" or OPEN position. The remaining switches must be left in the "0" or closed position. To position one of the nine switches to a setting of "1," use a non-conductible pointed tool and set the switch toward the side of the address switch labeled "OPEN." To position one of the nine switches to a setting of "0," use a non-conductible pointed tool and set the switch toward the side of the address switch marked with numbers "1" through "9."

To arrive at the combination of binary numbers that will equal the target number, first select the largest of the nine binary numbers whose equivalent real number can be subtracted from the target number (reference table 2-4). Subtract the real number (that is equivalent to the binary number) from the target number. Then continue to subtract the largest possible binary number from each remaining real number until zero is reached. For each binary number selected, the corresponding address switch is then set to the OPEN position. The remaining switches are left in the closed position.

For example, if the target number is 341, the binary code setting on the address switch would be determined as follows:

341	(target number)
- <u>256</u>	(real number value of binary number 9)
85	
- <u>64</u>	(real number value of binary number 7)
21	
- <u>16</u>	(real number value of binary number 5)
5	
- <u>4</u>	(real number value of binary number 3)
1	
- <u>1</u>	(real number value of binary number 1)
0	

When the real number equivalents of binary numbers 1, 3, 5, 7, and 9 are added together, the result is 341, the same number as the target. Address switches 1, 3, 5, 7, and 9 would then be set to OPEN. The remaining switches would be left in the closed position.

c. **Assembly and Preparation of ICB/High Power.** To assemble and prepare the ICB/High Power, refer to figure 2-5 and FO-1 and perform the following steps:

**WARNING**



**Ensure range power to ICB/High Power is off before performing the following steps. Failure to do so could result in death or serious injury.**

- (1) Turn off range power to ICB/High Power.
- (2) Place ICB/High Power CB1 (1) in the POWER OFF position.
- (3) Install cable assembly W101-2 to TB7 (2) terminals 3, 4, 6, 7, 8, 9, 10, 11, and 12.
- (4) Install cable assembly W101-2 P3 (3) from ICB/High Power to IMTC connector J2.
- (5) Install cable assembly W102-2 to TB3 (4) terminals 2, 3, 4, 5, 8, 9, and E4.
- (6) Install cable assembly W102-2 P2 (5) from ICB/High Power to IMTC connector J1.
- (7) Install range power cable (6) to TB5 terminals 1 and 2, E7 (7), and E8 (8).
- (8) Install range signal cable (9) to TB1 terminals 3, 4, 5, 6, 7, 8, 9, 10 and E2 (10).
- (9) Turn on range power to ICB/High Power.
- (10) Place ICB/High Power CB1 in the POWER ON position.

2-4 ASSEMBLY AND PREPARATION FOR USE (CONTINUED).

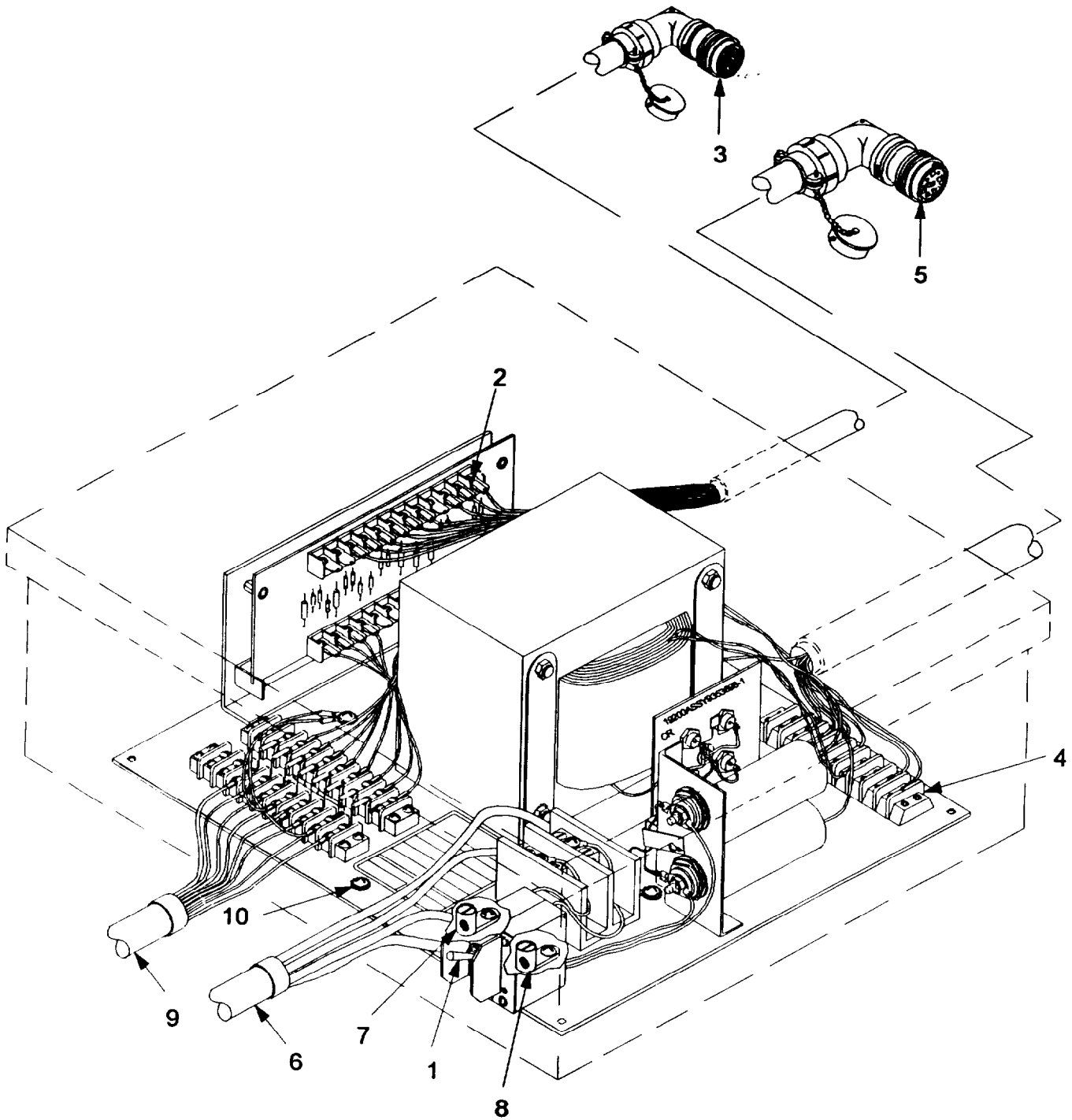
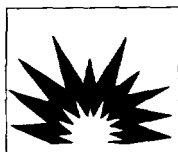

Figure 2-5. Preparation for Use of the ICB/High Power.



d. **Assembly and Preparation of ICB/Low Power.** To assemble and prepare the ICB/Low Power for operation, refer to figure 2-6 and FO-3 and perform the following steps:

**WARNING**



Disarm, then disconnect the gunfire simulator (GUFS) from ICB/Low Power. The GUFS must be disconnected before performing the next steps. Failure to do so could result in death or serious injury.

**WARNING**

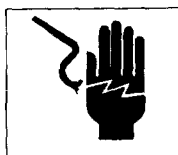

Ensure range power to ICB/Low Power is off before performing the following steps. Failure to do so could result in death or serious injury.

- (1) Turn off range power to ICB/Low Power.
- (2) Place ICB/Low Power CB1 (1) in the POWER OFF position.
- (3) Install cable assembly W101-1 to TB7 (2) terminals 3, 4, 6, 7, 8, 9, 10, 11, and 12.
- (4) Install cable assembly W101-1 P3 (3) from ICB/Low Power to TIU connector J2.
- (5) Install cable assembly W102-1 to TB3 (4) terminals 2, 3, 4, 5, 8, 9, and E4.
- (6) Install cable assembly W102-1 P2 (5) from ICB/Low Power to TIU connector J1
- (7) Install range power cable (6) to TB5 terminals 1 and 2, E7 (7), and E8 (8).
- (8) Install range signal cable (9) to TB1 terminals 3, 4, 5, 6, 7, 8, 9, 10 and E2 (10).

**NOTE**

**For loading and operation of the GUFS, refer to TM 9-6920-742-14-2.**

- (9) Position gunfire simulator in protected area. Clear brush and other flammable material away from GUFS. Connect the GUFS to ICB/Low Power.
- (10) Turn on range power to ICB/Low Power.
- (11) Place ICB/Low Power CBI in the POWER ON position.

**2-4 ASSEMBLY AND PREPARATION FOR USE (CONTINUED).**

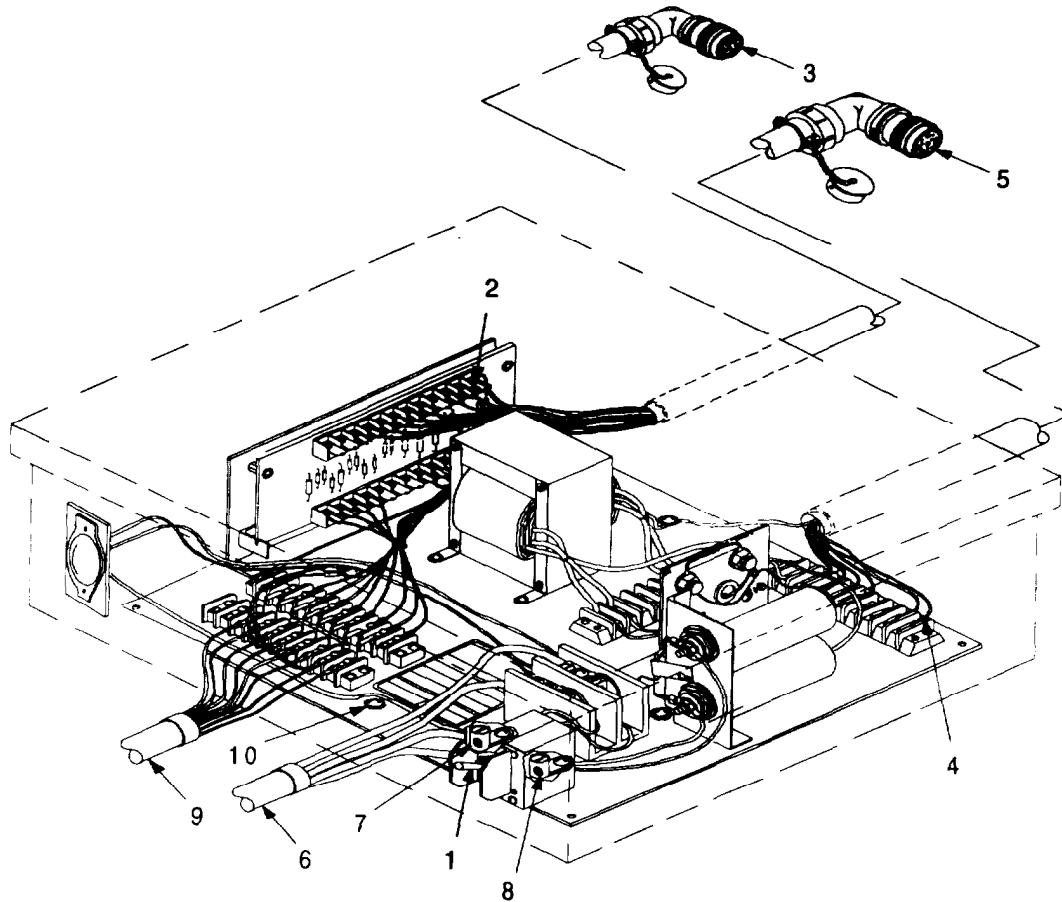

Figure 2-6. Preparation for Use of the ICB/Low Power.

**2-5 INITIAL ADJUSTMENTS, DAILY CHECKS, AND SELF-TEST.**

There are no initial adjustments, daily checks, or self-tests for the TIU, ICB/High Power, or ICB/Low Power.

**2-6 OPERATING PROCEDURES.**

There are no operating procedures for the TIU, ICB/High Power, or ICB/Low Power. All operation beyond assembly and preparation for use is controlled by the range control station ERETS.

**2-7 DECALS AND INSTRUCTION PLATES.**

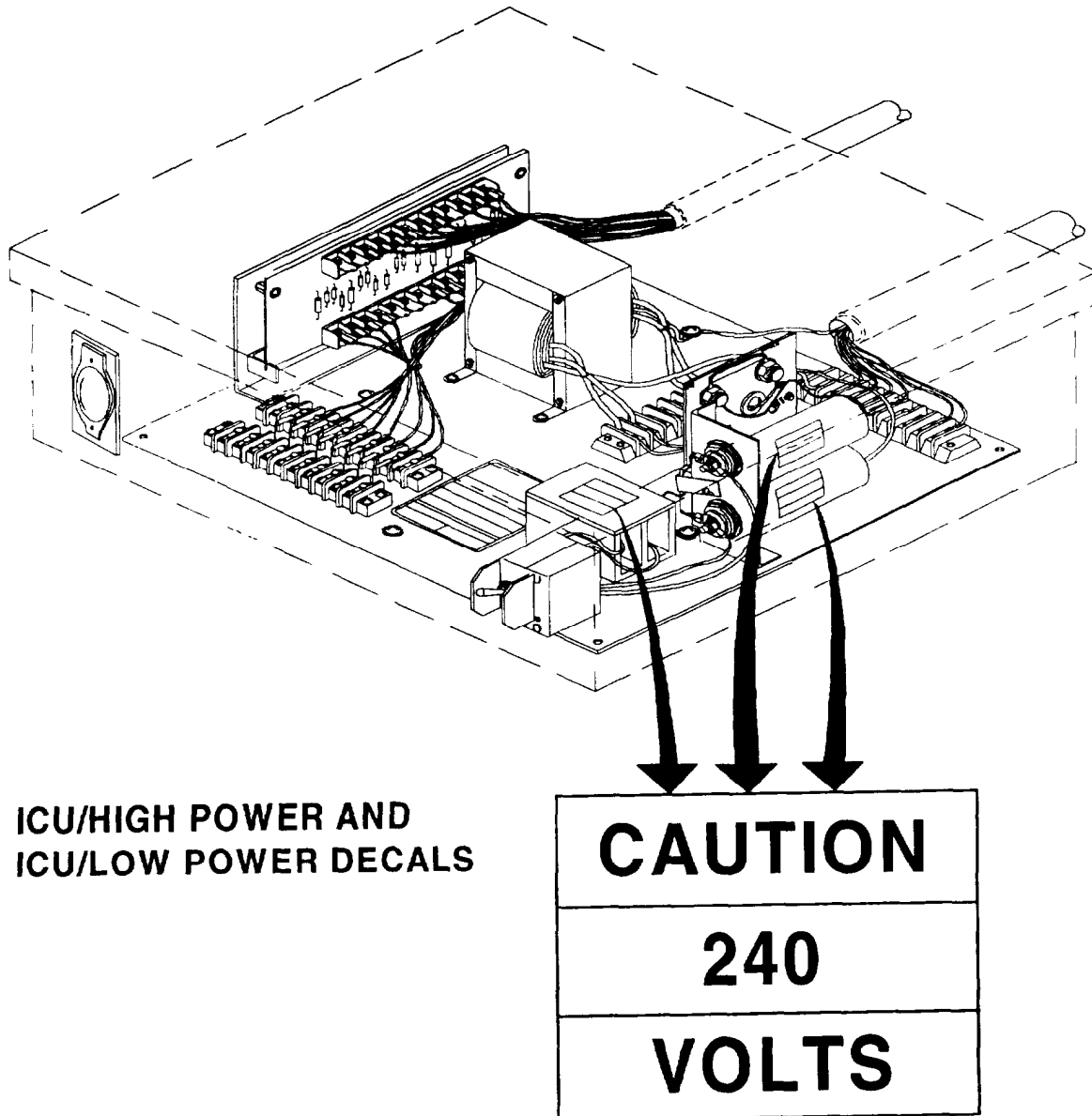

Figure 2-7. Decals and Instruction Plates.



## CHAPTER 3

### OPERATOR MAINTENANCE INSTRUCTIONS

#### SECTION I. LUBRICATION INSTRUCTIONS

##### 3-1 LUBRICATION.

There are no operator lubrication instructions for the Interconnecting Box, Target Interface Unit (TIU); Interconnecting Box, High Power (ICB/High Power); or the Interconnecting Box, Low Power (ICB/Low Power).

#### SECTION II. OPERATOR TROUBLESHOOTING PROCEDURES

##### 3-2 GENERAL.

Operator troubleshooting of the TIU, is limited to checking for proper address switch setting. To set the TIU address switch, refer to paragraph 2-4b. Any other malfunctions of the TIU, ICB/High Power, or the ICB/Low Power should be referred to unit maintenance.

#### SECTION III. OPERATOR MAINTENANCE PROCEDURES

##### 3-3 INTRODUCTION.

There are no operator maintenance procedures for the TIU, ICB/High Power, or the ICB/Low Power.



## CHAPTER 4

### UNIT MAINTENANCE INSTRUCTIONS

#### SECTION I. SERVICE UPON RECEIPT

##### 4-1 GENERAL.

Unpacking, installation, and preliminary servicing and adjustment of the Interconnecting Box, Target Interface (TIU); Interconnecting Box, High Power (ICB/High Power); and Interconnecting Box, Low Power (ICB/Low Power), are performed by a Headquarters, TACOM-ACALA contractor. Other than inspection of replacement parts, no service upon receipt is required by unit level maintenance.

#### SECTION II. UNIT PREVENTIVE MAINTENANCE CHECKS AND SERVICES (PMCS)

##### 4-2 GENERAL.

- a. **Corrosion.** Refer to paragraph 1-5.
- b. **Monthly Touchup/Spot Painting.** Painting is limited to touchup/spot painting.
- c. **Daily.** Always keep in mind the WARNINGS and CAUTIONS. Perform your daily (D) PMCS prior to the TIU, ICB/High Power, and ICB/Low Power performing their intended missions.
- d. **Always** keep in mind the WARNINGS and CAUTIONS while you perform your weekly (VV) PMCS.
- e. **Monthly.** Always keep in mind the WARNINGS and CAUTIONS while you perform your monthly (M) PMCS.
- f. **If Your Equipment Fails to Operate.** Troubleshoot with proper equipment. Report any deficiencies using the proper forms. See DA Pam 738-750.

##### 4-3 PMCS PROCEDURES.

- a. **Preventive Maintenance Checks and Services Table.** Lists the inspections and care of your equipment required to keep it in good operating condition.
- b. **Item Number Column.** The item number column is used for reference. When completing DA Form 2404, Equipment Inspection and Maintenance worksheet, include the item number for the check/service indicating a fault. Item numbers also appear in the order that you must do checks and services for intervals listed.
- c. **Interval Column.** The interval column tells you when to do a certain check or service.

d. **Perform Weekly as Well as Before Operations PMCS if.**

- (1) You are assigned operator and have not operated the TIU, ICB/High Power, or ICB/Low Power since the last weekly.
- (2) You are operating the TIU, ICB/High Power, or ICB/Low Power for the first time.

e. **While You Perform PMCS. Have Tools with You and Keep an Eye Out for the Following.**

(1) **Loose Bolts.** A loose bolt can be difficult to spot without using a wrench. However, you can often identify loose bolts by observing loose or chipped paint around bolt head and bare metal or rust at its base. Tighten loose bolt and spot paint as required.

(2) **Damaged Welds.** Damaged welds may be detected by observing rust or chipped paint where cracks occur.

(3) **Frayed Electrical Wires and Loose Connectors.** Check electrical wiring for cracks due to aging and exposed wires that could cause an electrical short. Tighten loose clamps and connectors.

(4) **Corrosion.** Check for signs of deterioration, rust, unusual cracking, softening, swelling, or breaking.

f. **Leakage Definitions for PMCS Shall be Classified as Follows.**

**CAUTION**

**Equipment operation is allowable with minor leakages (Class I or II). Of course, you must consider the fluid capacity in the item/system being checked or inspected. When in doubt, notify your supervisor. When operating with Class I or Class II leaks, continue to check fluid levels as required in your PMCS.**

- (1) Class I leakage is seepage of fluid (as indicated by wetness or discoloration) not great enough to form drops.
- (2) Class II leakage is leakage of fluid great enough to form drops but not enough to cause drops to drip from item being checked/inspected.
- (3) Class III leakage is leakage of fluid great enough to form drops that fall from item being checked/inspected. Class III leaks should be reported to your supervisor or direct support maintenance.

g. **Damage Definitions Are as Follows.**

- (1) **Burr.** A raised portion, restricting the entrance of a part, component, or assembly.
- (2) **Crack.** A narrow break or separation in material.
- (3) **Gouge.** A groove or cavity in a sealing surface that cannot be repaired.
- (4) **Nick.** An indentation caused by object(s) striking the material.



**h. The Item to be Checked or Serviced Column.** Identifies the item to be serviced.

**i. The Procedures Column.** Tells you how to do the required checks and services. Carefully follow these instructions. If you do not have the tools, or if the procedure tells you to, notify direct support maintenance.

**j. If Your Equipment Does Not Perform as Required.** Refer to the troubleshooting table for possible problems. Report any malfunctions or failures on DA Form 2404, or refer to DA Pam 738-750.

**Table 4-1. Unit Preventive Maintenance Checks and Services.**

ITEM NO	INTERVAL			ITEM TO BE INSPECTED	PROCEDURES CHECK FOR AND HAVE REPAIRED OR ADJUSTED AS NECESSARY	EQUIPMENT NOT READY/ AVAILABLE IF:
	D	W	M			
1	•			TIU	Inspect all cables and TIU housing for damage or loose connections.	Housing or cables are damaged or connections are loose.
2	•			ICB/High Power	Inspect all cables and ICB/High Power for damage and loose connections.	ICB/High Power or cables are damaged or connections are loose.
3	•			ICB/Low Power	Inspect all cables and ICB/Low Power for damage and loose connections.	ICB/Low Power or cables are damaged or connections are loose.

**SECTION III. TROUBLESHOOTING PROCEDURES**

**4-4 TROUBLESHOOTING PROCEDURES.**

Table 4-2 lists the common malfunctions that you may find during operation or maintenance of the TIU, ICB/High Power, and ICB/Low Power. You should perform the tests/inspections and corrective actions in the order listed. Before you begin troubleshooting, ensure that unit PMCS have been performed. The following procedures are based on the premise that unit PMCS have been completed. If in doubt, perform PMCS in accordance with procedures described in table 4-1. This manual cannot list all the malfunctions that may occur nor all the tests or inspections and corrective actions. Notify your supervisor if a malfunction persists and cannot be corrected by prescribed action.

**WARNING**

Personnel working with or near high voltages must be trained and certified in mouth-to-mouth and cardiopulmonary resuscitation. Installation medical activities shall provide certified instructors. Newly assigned maintenance personnel must be trained as soon as practical.

Make sure at least two persons are in the area at all times when work is being performed on exposed live circuits carrying 30 volts or more.

**Malfunction Index**

	<b>Malfunction</b>
<b>TIU/ICB (high and low power)</b>	
Target will not operate while other targets on the lane are operational	1
TIU is inoperative	2
<b>ICB/High Power</b>	
IMTC connected to ICB/High Power will not operate by TEST switch	3
IMTC connected to ICB/High Power will not respond to commands from the RCS	4
<b>ICB/Low Power</b>	
Target mechanism connected to ICB/Low Power will not operate by TEST switch	5
Target mechanism connected to ICB/Low Power will not respond to command from the RCS	6

**Table 4-2. Unit Troubleshooting Procedures.**

---

**MALFUNCTION  
TEST OR INSPECTION  
CORRECTIVE ACTION**

---

1. Target will not operate while other targets on the lane are operational.

**WARNING**

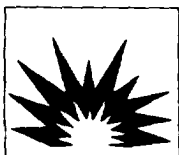

Disarm, then disconnect the GUFs connection from AMTC, THM/TG, or TIU. The GUFs must be disconnected before performing maintenance. Explosion is possible and can cause personal injury and damage to equipment. Pyrotechnics are used during range operation.

**WARNING**



High voltages are present inside the equipment. Death or injury from electric shock may result from failure to observe safety precautions.

- Step 1. Check that CB1 on the ICB/Low Power, TIU, and target are in the ON position. Ensure all cables are properly and securely connected.

If any circuit breakers were off, place them in the ON position.

Table 4-2. Unit Troubleshooting Procedures - Continued.

---

**MALFUNCTION**  
**TEST OR INSPECTION**  
**CORRECTIVE ACTION**

---

Step 2. Attempt to operate the target in accordance with appropriate target manual.

If the ICB/Low Power CB1 trips, remove cable W102-1 connector P1 from TIU J1 . Reset CB1 to the ON position and retest the system. If ICB/Low Power continues to trip, the ICB/Low Power is at fault. Refer to ICB/Low Power troubleshooting. If ICB/Low Power CB1 no longer trips, the TIU is at fault. Proceed to malfunction 2.

If the TIU CBI trips, disconnect appropriate cable from TIU J3. Reset CB1 to the ON position and retest the system. If TIU CB1 continues to trip, the TIU is at fault. Proceed to malfunction 2. If TIU CB1 now holds, TIU is good. Refer to appropriate target manual for troubleshooting.

if no circuit breakers trip and target still fails to operate, proceed to step 3.

Step 3. Using multimeter, check for voltages in and out of ICB/Low Power and TIU at the following points:

<u>RED LEAD</u>	<u>BLACK LEAD</u>	<u>READING</u>
ICB/Low Power TB5-1	ICB/Low Power TB5-2	240 ±4 vac
ICB/Low Power TB3-5	ICB/Low Power TB3-1	24 ±3 vdc
TIU AITB1-1	TIU A1TB1-7	24 ±3 vdc
TIU 53 pin q	TIU J3 pin r	12±1.5 vdc

If all multimeter readings are correct, proceed to step 4.

If multimeter readings into ICB/Low Power are not correct, check facility power. If multimeter readings out of ICB/Low Power are not correct, refer to iCB/Low Power troubleshooting. if multimeter readings into TIU are not correct, refer to ICB/Low Power troubleshooting. If readings out of TIU are not correct, refer to malfunction 2.

Table 4-2. Unit Troubleshooting Procedures - Continued.

---

**MALFUNCTION**  
**TEST OR INSPECTION**  
**CORRECTIVE ACTION**

---

Step 4. Insure all components of the RCS are turned on and operational with a loaded scenario. Place ICB/Low Power CB1 in the OFF position and remove 240 vac incoming power. Open ICB/Low Power and place multimeter leads on the following points and check for dc voltage:

<b>RED LEAD</b>	<b>SIGNAL</b>	<b>BLACK LEAD</b>	<b>READING</b>
TB1-3	status	TB1-4	meter fluctuation
TB1-5	status pwr	TB1-6	12 ±1.5vdc
TB1-7	clock	TB1-8	3 vdc min ERETS
TB1-9	data	TB1-10	meter fluctuation 20-24 vdc
TB2-3	status	TB2-4	meter fluctuation
TB2-5	status pwr	TB2-6	12 ±1.5 vdc
TB2-7	clock	TB2-8	3 vdc min ERETS
TB2-9	data	TB2-10	meter fluctuation 20-24 vdc
TB8-1	status	TB8-2	meter fluctuation
TB8-3	status pwr	TB8-8	12 ±1.5 vdc
TB8-9	clock	TB8-10	3 vdc min ERETS
TB8-11	data	TB8-12	meter fluctuation 20-24 vdc
TB7-6	status	TB7-7	meter fluctuation
TB7-3	status pwr	TB7-8	12 ±1.5vdc
TB7-10	clock	TB7-9	3 vdc min ERETS
TB7-12	data	TB7-11	meter fluctuation 20-24 vdc

If indications are correct, ICB/Low Power data circuit is operational. Refer TIU to next higher level of maintenance.

If any multimeter indications are not correct, ICB/Low Power is at fault. Refer to ICB/Low Power troubleshooting.

**2. TIU is inoperative.**

**WARNING**

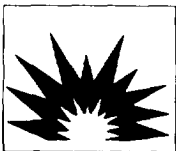

Disarm, then disconnect the GUFFS connection from AMTC, THM/TG, or TIU . The GUFFS must be disconnected before performing maintenance. Explosion is possible and can cause personal injury and damage to equipment. Pyrotechnics are used during range operation.

Table 4-2. Unit Troubleshooting Procedures - Continued.

MALFUNCTION	TEST OR INSPECTION	CORRECTIVE ACTION
-------------	--------------------	-------------------

**WARNING**



High voltages are present inside the equipment. Death or injury from electric shock may result from failure to observe safety precautions.

- Step 1. With CB1 in the ON position, place multimeter red lead on A1TB1 terminal 1 and black lead on A1TB1 terminal 7 (see FO-1). Multimeter should read  $24 \pm 3$  vdc.
- If reading is correct, proceed to step 2.
- If reading is incorrect, place CB1 in the OFF position. Remove P2 from J1 of TIU and use multimeter to check for continuity from J1 pin D to A1TB1 terminal 1 and from J1 pin H to A1TB1 terminal 7. If continuity is found, refer to ICB/Low Power troubleshooting. If continuity is not found, refer to next higher level of maintenance for wiring repair.
- Step 2. With CB1 in the ON position, place multimeter red lead on A1TB1 terminal 4 and black lead on A1TB1 terminal 8 (see FO-1). Multimeter should read  $24 \pm 3$  vdc.
- If reading is correct, proceed to step 3.
- If reading is incorrect, notify next higher level of maintenance to replace CB1 .
- Step 3. With CB1 in the ON position, place multimeter red lead on A2TB1 terminal 3 and black lead on A2TB1 terminal 2. Multimeter should indicate  $12 \pm 1.5$  vdc.
- If reading is correct, notify next higher level of maintenance.
- If reading is incorrect, check power supply terminal lugs for loose connection. If loose terminal lug is found, replace in accordance with paragraph 4-9, 4-10, or 4-11 and repeat step 3. If reading is still incorrect, replace power supply in accordance with paragraph 4-8 and repeat step 3. If TIU still fails to operate, proceed to step 4.
- Step 4. For use with the THM/TG only. Place CB1 in the OFF position. Remove cable W107 from TIU connector J3 and all THM/TG connections. Using multimeter, test cable W107 for continuity at the following points:

Table 4-2. Unit Troubleshooting Procedures - Continued.

**MALFUNCTION**  
**TEST OR INSPECTION**  
**CORRECTIVE ACTION**

<u>RED LEAD</u>	<u>BLACK LEAD</u>
P1-G	P4-B
P1-h	P4-C
P1-F	P4-A
P1-A	Shield
P1-b	P3-D
P1-j	P3-E
P1-d	P3-F
P1-V	P3-NC (see NOTE below)
P1-H	P3-G
P1-X	P3-NC (see NOTE below)
P1-q	P3-K
P1-r	P3-A
P1-n	P3-N
P1-p	P3-M
P2-D	P4-D
P2-A	P4-A
P2-C	P4-C
P2-B	P4-B

**NOTE**

The reference to "NC" means no connection; therefore, check continuity with all connector pins (P1-V and P1-X check continuity with all P3 pins).

If continuity is found, refer TIU to next higher level of maintenance.

If continuity is not found, replace W107 cable and exercise THMTG in accordance with TM 9-6920-742-14-5. If THM/TG now operates normally, TIU is operational. If THM/TG still fails to operate, refer TIU to next higher level of maintenance

3. IMTC connected to ICB/High Power will not operate by TEST switch.

**WARNING**

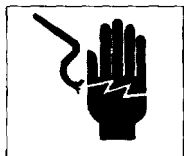

High voltages are present inside the equipment. Death or injury from electric shock may result from failure to observe safety precautions.

Step 1. Check all cables for serviceability. Ensure all cables are properly and securely connected and circuit breaker is in the ON position (see FO-2).

**Table 4-2. Unit Troubleshooting Procedures - Continued.**

<b>MALFUNCTION</b>	<b>TEST OR INSPECTION</b>	<b>CORRECTIVE ACTION</b>
	Step 2. Remove lid. Using multimeter, check for 240 ±24 vac between TB5 terminals 1 and 2.	
	If proper voltage is present, proceed to step 3.	
	If proper voltage is not present, lane power cable is open. Refer to TM 9-6920-742-14-1.	
	Step 3. Using multimeter, place red lead on input terminal of FL1 and black lead on input terminal of FL2. Multimeter should indicate 240 ±24 vac.	
	If proper voltage is present, proceed to step 4.	
	If proper voltage is not present, replace circuit breaker assembly in accordance with paragraph 4-14 and repeat step 3.	
	Step 4. Using multimeter, check for 28 ±3 vdc between TB3-1 and TB3-5.	
	If proper voltage is present, proceed to step 5.	
	If proper voltage is not present, refer to next higher level of maintenance.	
	Step 5. Place CB1 in the OFF position and remove power from 240 vac incoming power line. Using multimeter, test cable W102-2 for continuity from point to point and point to ground using the following chart.	

<u>P1 pin</u>	<u>TB3 terminal</u>
D	4
G	3
<b>E</b>	5
H	2
A	8
P	9
F (SHIELD)	CHASSIS
K (SHIELD)	CHASSIS

If continuity is found in accordance with the chart, ICB/High Power power circuits are operational.

If continuity is not found, replace cable W102-2 in accordance with paragraph 4-18.

Table 4-2. Unit Troubleshooting Procedures - Continued.

---

<b>MALFUNCTION</b>	
<b>TEST OR INSPECTION</b>	
<b>CORRECTIVE ACTION</b>	

---

4. IMTC connected to ICB/High Power does not respond to commands from the RCS.

**WARNING**



High voltages are present inside the equipment. Death or injury from electric shock may result from failure to observe safety precautions.

- Step 1. Check that IMTC connected to the ICB/High Power responds to TEST switch.  
 If IMTC responds to TEST switch, proceed to step 2.  
 If IMTC fails to respond to test switch, proceed to malfunction 3.
- Step 2. Place CB1 in the OFF position.
- Step 3. Remove power from 240 vac incoming power line.
- Step 4. Remove cable W101-2 connector P3 from IMTC.
- Step 5. Using multimeter, check cable W101-2 for point to point and point to ground continuity using the following chart.

<u>P3</u>	<u>TB7</u>
C	12
d	11
X	4
e	10
f	9
Y	4
i	3
i	8
Z	4
h	6
g	7
b	4
L	4



Table 4-2. Unit Troubleshooting Procedures - Continued.

MALFUNCTION	TEST OR INSPECTION	CORRECTIVE ACTION
-------------	--------------------	-------------------

If continuity is found, proceed to step 6.

If continuity is not found, replace cable W101-2 in accordance with paragraph 4-17.

- Step 6. Place CB1 in the OFF position and remove power from 240 vac incoming power line. Place SDA circuit breakers in the OFF position in accordance with TM 9-6920-742-14-1. Using multimeter, check for continuity of wiring harness from point to point and point to ground using the following chart.

<u>TB2</u>	<u>TB8</u>	<u>GROUND</u>
3	1	
4	2	
5	3	
6	8	
7	9	
8	10	
9	11	
10	12	
	4	E5

If continuity is found, refer to next higher level of maintenance.

If continuity is not found, replace wiring harness in accordance with paragraph 4-15.

**5. Target mechanism or simulator connected to ICB/Low Power will not operate by TEST switch.**

**WARNING**

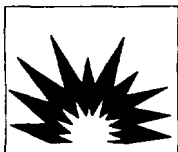

Disarm, then disconnect the GUFs connection from ICB/Low Power. The GUFs must be disconnected before performing maintenance. Explosion is possible and can cause personal injury and damage to equipment. Pyrotechnics are used during range operation.

**WARNING**



High voltages are present inside the equipment. Death or injury from electric shock may result from failure to observe safety precautions.

Table 4-2. Unit Troubleshooting Procedures - Continued.

**MALFUNCTION**

**TEST OR INSPECTION**

**CORRECTIVE ACTION**

- 
- Step 1. Check all cables for serviceability. Ensure all cables are properly and securely connected and circuit breakers are in the ON position (see FO-4).
- Step 2. Remove lid. Using multimeter check for 240 ±4 vac between TB5 terminals 1 and 2.
- If proper voltage is present, proceed to step 3.
- If proper voltage is not present, lane power cable is open. Refer to TM 9-6920-742-1.
- Step 3. Using multimeter, place red lead on input terminal of FL1 and black lead on input terminal of FL2. Multimeter should read 240 ±24 vac.
- If proper voltage is present, proceed to step 4.
- If proper voltage is not present, replace circuit breaker assembly in accordance with paragraph 4-20 and repeat step 3.
- Step 4. Using multimeter, check for 34 ±3 vdc between TB3-1 and TB3-5 (when target is commanded up/down multimeter should read 24 ±3 vdc.)
- If proper voltage is present, proceed to step 5.
- If proper voltage is not present, refer to next higher level of maintenance.
- Step 5. Place CB1 in the OFF position and remove power from 240 vac incoming power line. Using multimeter, test cable W102-1 for continuity from point to point and point to ground using the following chart.

<u>P1 pin</u>	<u>TB3 terminal</u>
D	4
G	3
E	5
H	2
A	8
P	9
F (SHIELD)	CHASSIS
K (SHIELD)	CHASSIS

If continuity is found in accordance with the chart, ICB/Low Power is Operational.

If continuity is not found, replace cable W102-1 in accordance with paragraph 4-24.

Table 4-2. Unit Troubleshooting Procedures - Continued.

---

**MALFUNCTION**  
**TEST OR INSPECTION**  
**CORRECTIVE ACTION**

---

6. Target mechanism or simulator connected to ICB/Low Power will not respond to commands from the RCS.

**WARNING**

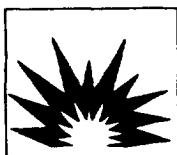

Disarm, then disconnect the GUFFS connection from ICB/Low Power. The GUFFS must be disconnected before performing maintenance. Explosion is possible and can cause personal injury and damage to equipment. Pyrotechnics are used during range operation.

**WARNING**



High voltages are present inside the equipment. Death or injury from electric shock may result from failure to observe safety precautions.

Step 1. Check that target mechanism or simulator connected to the ICB/Low Power responds to its TEST switch.

If unit responds to TEST switch, proceed to step 2.

If unit fails to respond to TEST switch, proceed to malfunction 5.

Step 2. Place CB1 in the OFF position.

Step 3. Remove power from 240 vac incoming power line.

Step 4. Remove cable W101-1 connector P3 from TIU.

Step 5. Using multimeter, check cable W101-1 for point to point and point to ground continuity using the following chart.

<u>P3</u>	<u>TB7</u>
c	12
d	11
X	4
e	10
f	9

Table 4-2. Unit Troubleshooting Procedures - Continued.

---

MALFUNCTION	TEST OR INSPECTION	CORRECTIVE ACTION
-------------	--------------------	-------------------

---

<u>P3</u>	<u>TB7</u>
Y	4
i	3
j	8
Z	4
h	6
g	7
b	4
K	4

If continuity is found, proceed to step 6.

If continuity is not found, replace cable W101-1 in accordance with paragraph 4-23.

- Step 6. Place CB1 in the OFF position and remove 240 vac incoming power. Place SDA circuit breakers in the OFF position. Using multimeter, check for continuity of wiring harness from point to point and point to ground using the following chart.

<u>TB2</u>	<u>TB8</u>	<u>GROUND</u>
3	1	
4	2	
5	3	
6	8	
7	9	
8	10	
9	11	
10	12	
	4	E5

If continuity is found, refer to next higher level of maintenance.

If continuity is not found, replace wiring harness in accordance with paragraph 4-21.

## SECTION IV. UNIT MAINTENANCE PROCEDURES

4-5 TIU REPLACEMENT (9353787).

## INITIAL SETUP

## Tools and Special Tools:

General mechanic's automotive tool kit

## References:

Paragraph 2-4b

## Materials/Parts:

TIU (9353787)

Grease (item 2, appendix D)

## Personnel Required:

2 persons (for safety purposes)

**a. Removal.**

- (1) Set CB1 of ICB/Low Power to the OFF position.
- (2) Set TIU CB1 (1) to the OFF position.
- (3) Disconnect cables from connectors J1 thru J5 as required.

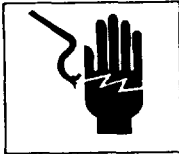
**WARNING**

When working inside the equipment after power has been turned off, always ground every part before touching it. Failure to do so could result in serious injury or death.

- (4) Depress pressure relief valve (2) to equalize pressure before removing cover assembly.
- (5) Release latches and remove cover assembly (3).
- (6) Record dual-in-line/address switch (4) position.
- (7) Install cover assembly and fasten latches.
- (8) Remove holddown pins from base (5).
- (9) Remove TIU.

**b. Installation.**

- (1) Place TIU on range pad.
- (2) Install holddown pins on base (5).

4-5 TIU REPLACEMENT (9353787) (CONTINUED).

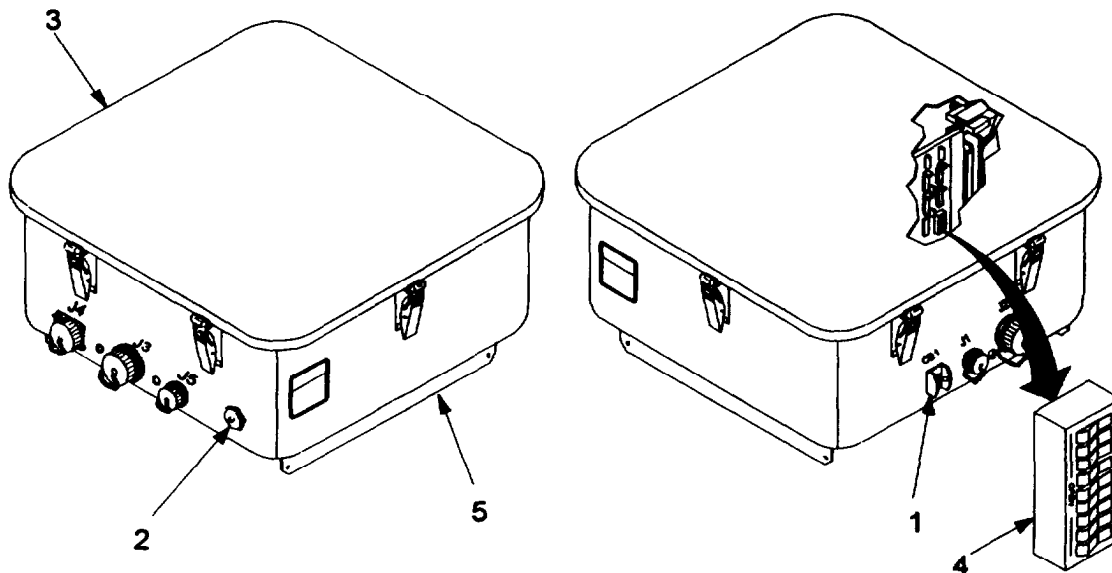

**WARNING**



When working inside the equipment after power has been turned off, always ground every part before touching it. Failure to do so could result in serious injury or death.

- (3) Depress pressure relief valve to equalize pressure before removing cover assembly.
- (4) Release latches and remove cover assembly.
- (5) Set dual-in-line/address switch (4) position in accordance with recorded address. If address was not recorded, determine switch position in accordance with paragraph 2-4b.
- (6) Apply a uniform, thin coating of grease to entire gasket surface.
- (7) Install cover assembly (3) and fasten latches.
- (8) Connect cables to connectors J1 thru J5 as required (see FO-4).
- (9) Set CB1 of ICB/Low Power to the ON position.
- (10) Set TIU CB1 (1) to the ON position.
- (11) Test target mechanism in accordance with appropriate technical manual.

**4-6 COVER ASSEMBLY REPLACEMENT (11829343-2).**

**INITIAL SETUP**

**Materials/Parts:**

Cover (11829343-2)  
Grease (item 2, appendix D)

**Personnel Required:**

2 persons (for safety purposes)

**a. Removal.**

- (1) Set CB1 of ICB/Low Power to the OFF position.
- (2) Set TIU CB1 (1) to the OFF position.

**WARNING**



When working inside the equipment after power has been turned off, always ground every part before touching it. Failure to do so could result in serious injury or death.

- (3) Depress pressure relief valve (2) to equalize pressure before removing cover assembly.
- (4) Release latches and remove cover assembly (3).

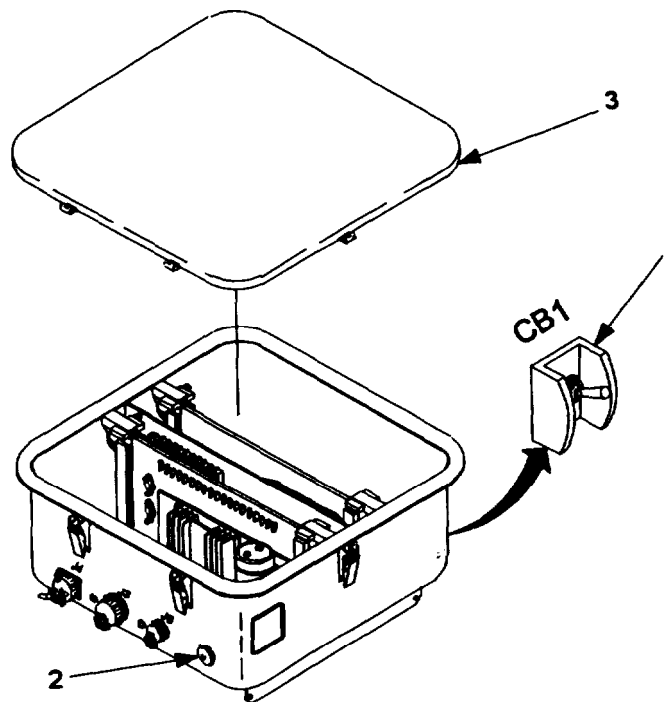

**4-6 TIU COVER ASSEMBLY REPLACEMENT (11829343-2CONTINUED).**

**b. Installation.**

- (1) Apply a uniform, thin coating of grease to entire gasket surface.
- (2) Install cover assembly (3) and fasten latches.
- (3) Set CB1 of ICB/Low Power to the ON position.
- (4) Set TIU CB1 (1) to the ON position.

**4-7 GASKETS REPLACEMENT (9387225) AND (11829403).**

**INITIAL SETUP**

**Tools and Special Tools:**

General mechanic's automotive tool kit

**Materials/Parts:**

Gasket (9387225)

Grease (item 2, appendix D)

Adhesive (item 1, appendix D)

Adhesive (item 1a, appendix D)

**Personnel Required:**

2 persons (for safety purposes)

---

**a. Removal.**

- (1) Set CB1 of ICB/Low Power to the OFF position.
- (2) Set TIU CB1 (1) to the OFF position.

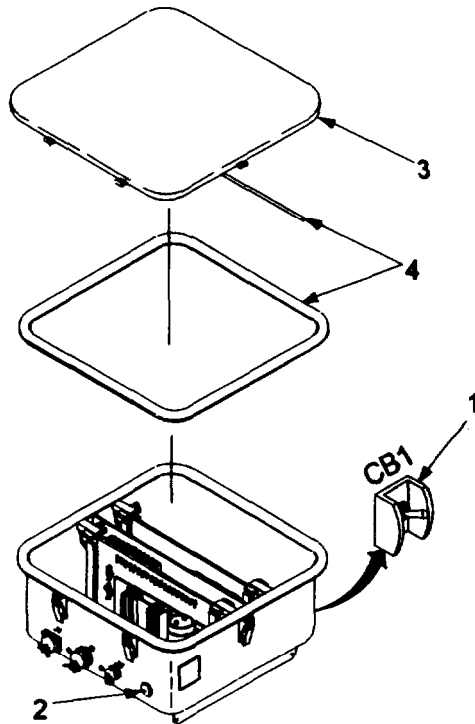



**WARNING**

When working inside the equipment after power has been turned off, always ground every part before touching it. Failure to do so could result in serious injury or death.

- (3) Depress pressure relief valve (2) to equalize pressure before removing cover assembly.
- (4) Release latches and remove cover assembly (3).
- (5) Scrape old gasket (4) from TIU housing.

**b. Installation.**

- (1) Apply adhesive (item 1, appendix D) to TIU housing gasket surface or adhesive (item 1a, appendix D) to TIU cover gasket surface area.
- (2) Position gasket on housing or cover.
- (3) Apply a uniform, thin coating of grease to entire housing gasket surface.
- (4) Install cover assembly (3) and fasten latches.
- (5) Set CB1 of ICB/Low Power to the ON position.
- (6) Set TIU CB1 (1) to the ON position.

**4-8 TIU POWER SUPPLY REPLACEMENT (9353789).****INITIAL SETUP****Tools and Special Tools:**

General mechanic's automotive tool kit

**Personnel Required:**

2 persons (for safety purposes)

**Materials/Parts:**

Power supply (9353789)  
Grease (item 2, appendix D)

**References:**

TM 9-6920-742-14-1

**a. Removal.**

- (1) Set CB1 of ICB/Low Power to the OFF position.
- (2) Set TIU CB1 (1) to the OFF position.

4-8 TIU POWER SUPPLY REPLACEMENT (9353789) (CONTINUED)

**WARNING**

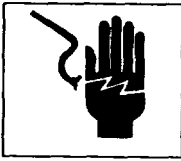

When working inside the equipment after power has been turned off, always ground every part before touching it. Failure to do so could result in serious injury or death.

- (3) Depress pressure relief valve (2) to equalize pressure before removing cover assembly.
- (4) Release latches and remove cover assembly.
- (5) Discharge capacitor to ground.
- (6) Tag and disconnect wires (3) from TB1 on power supply.
- (7) Remove four screws (4) and washers (5) from power supply.
- (8) Remove power supply (6).

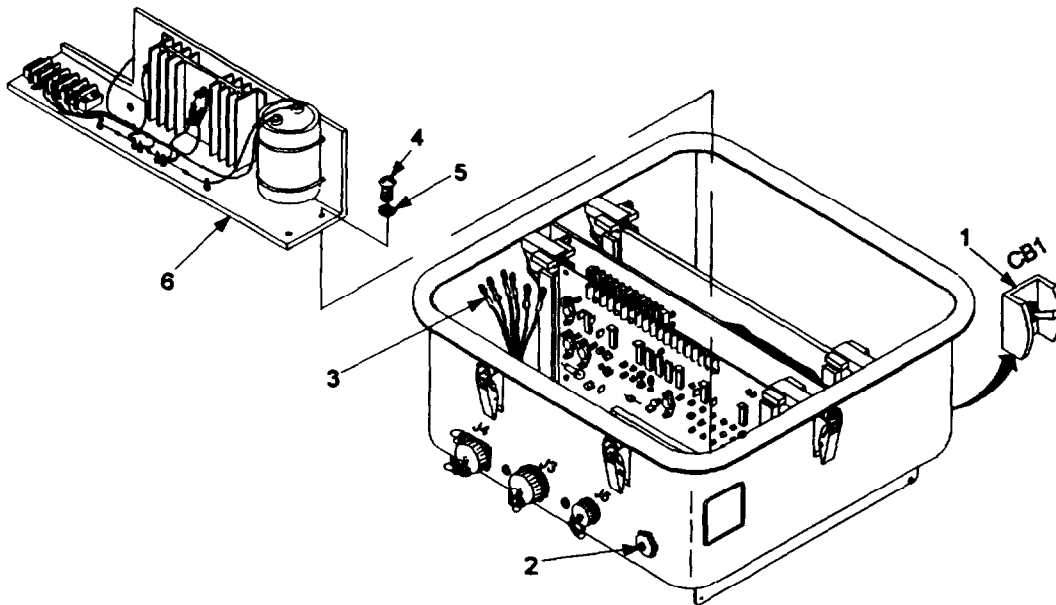

**b. Installation.**

- (1) Position power supply (6) on brackets.
- (2) Install four screws (4) and washers (5) in power supply.
- (3) Connect wires (3) to TB1.

- (4) Apply a uniform, thin coating of grease to entire gasket surface.
- (5) Install cover assembly and fasten latches.
- (6) Set CB1 of ICB/Low Power to the ON position.
- (7) Set TIU CB1 (1) to the ON position.
- (6) Test in accordance with TM 9-6920-742-14-111

**4-9 TIU POWER SUPPLY TERMINAL LUG REPLACEMENT (MS25036-103).**

**INITIAL SETUP**

**Tools and Special Tools:**

General mechanic's automotive tool kit  
Wire strippers

**Personnel Required:**

2 persons (for safety purposes)

**Materials/Parts:**

Terminal lug (MS25036-103)  
Locknut (MS21083C3)  
Grease (item 2, appendix D)

**References:**

TM 9-6920-742-14-1

- a. Set CB1 of ICB/Low Power to the OFF position.
- b. Set TIU CB1 to the OFF position.

**WARNING**

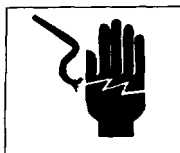

**When working inside the equipment after power has been turned off, always ground every part before touching it. Failure to do so could result in serious injury or death.**

**NOTE**

**Press pressure relief valve before removing cover assembly.**

- c. Release latches and remove cover assembly.
- d. Discharge capacitor to ground.
- e. Remove locknut (1) from diode.
- f. Remove terminal lug (2) from diode.
- g. Cut terminal lug from wire as close to lug as possible.

**4-9 TIU POWER SUPPLY TERMINAL LUG REPLACEMENT (MS25036-103) (CONTINUED).**

- h. Strip wire 3/8-inch (.953 cm).
- i. Insert wire in new terminal lug.
- j. Crimp terminal lug.
- k. Install terminal lug on diode.
- l. Secure with new locknut on diode.

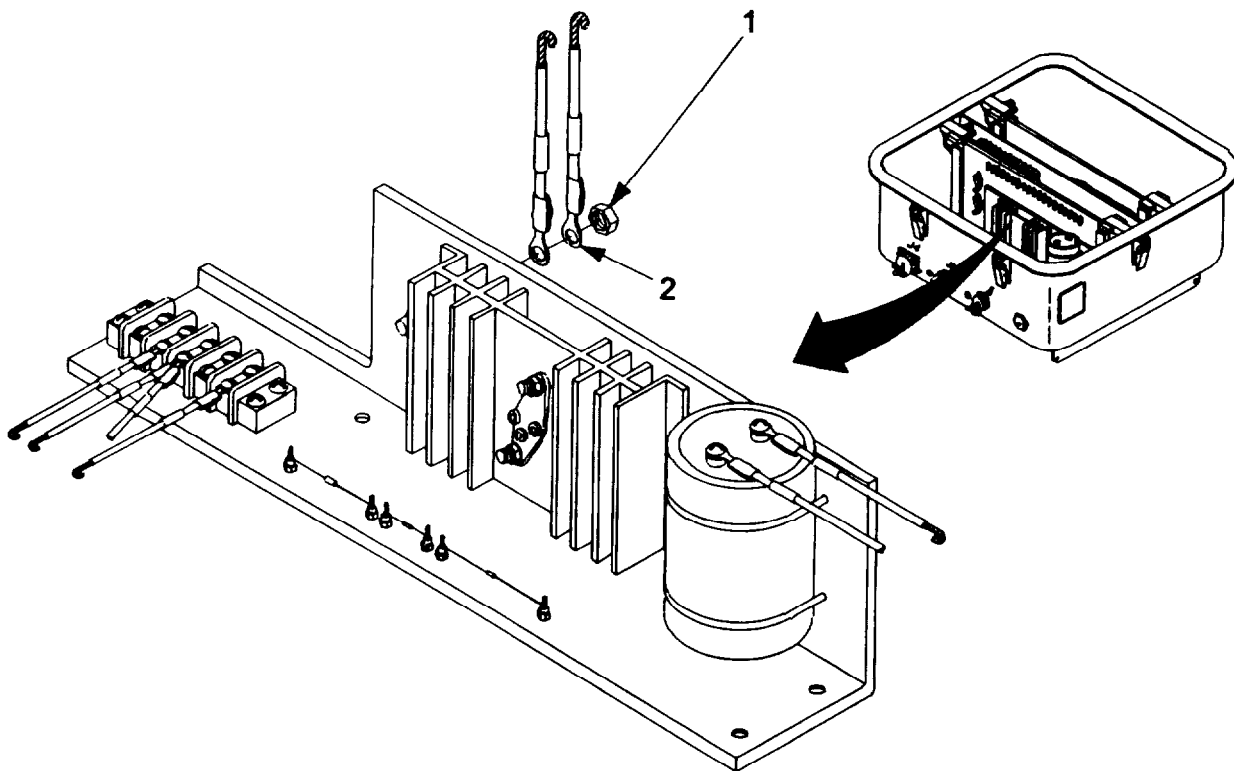

- m. Apply a uniform, thin coating of grease to gasket surface.
- n. Install cover assembly and fasten latches.
- o. Set CB1 of ICB/Low Power to the ON position.
- p. Set TIU CB1 to the ON position.
- q. Test in accordance with TM 9-6920-742-14-1.

**4-10 TIU POWER SUPPLY TERMINAL LUG REPLACEMENT (MS25036-106).**

**INITIAL SETUP**

**Tools and Special Tools:**

General mechanic's automotive tool kit  
Wire strippers

**Personnel Required:**

2 persons (for safety purposes)

**References:**

TM 9-6920-742-14-1

**Materials/Parts:**

Terminal lug (MS25036-106)  
Grease (item 2, appendix D)

- a. Set CB1 of ICB/Low Power to the OFF position.
- b. Set TIU CB1 to the OFF position.

**WARNING**



**When working inside the equipment after power has been turned off, always ground every part before touching it. Failure to do so could result in serious injury or death.**

- c. Depress pressure relief valve to equalize pressure before removing cover assembly.
- d. Release latches and remove cover assembly,

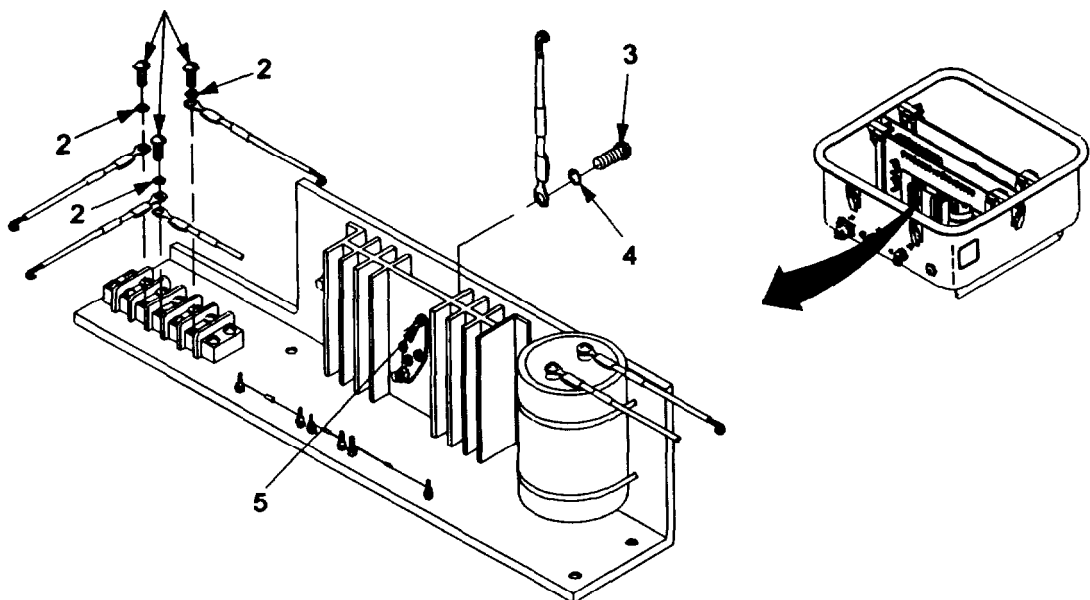

**4-10 TIU POWER SUPPLY TERMINAL LUG REPLACEMENT (MS25036-106) (CONTINUED).**

- e. Discharge capacitor to ground.
- f. Remove screws (1) and lockwashers (2) from TB1-1, TB1-3, and TB1-4.
- g. Remove terminal lugs from TB1.
- h. Remove screw (3) and flatwasher (4) from Q1-1 (5).
- i. Remove terminal lugs from Q1-1.
- j. Cut terminal lug from wire as close to lug as possible.
- k. Strip wire 3/8-inch (.953 cm).
- l. Insert wire in new terminal lug.
- m. Crimp terminal lug.
- n. Install terminal lug to Q1-1.
- o. Secure with screw and flatwasher.
- p. Install terminal lugs to TB1-1, TB1-3, and TB1-4.
- q. Secure with screws and lockwashers.
- r. Apply a uniform, thin coating of grease to gasket surface.
- s. Install cover assembly and fasten latches.
- t. Set CB1 of ICB/Low Power to the ON position.
- u. Set TIU CB1 to the ON position.
- v. Test in accordance with TM 9-6920-742-14-1.

**4-11 TIU POWER SUPPLY TERMINAL LUG REPLACEMENT (MS25036-108).****INITIAL SETUP****Tools and Special Tools:**

General mechanic's automotive tool kit  
Wire strippers

**Personnel Required:**

2 persons (for safety purposes)

**Materials/Parts:**

Terminal lug (MS25036-108)  
Locknut (MS21083C06)  
Grease (item 2, appendix D)

**References:**

TM 9-6920-742-14-1

- a. Set CB1 of ICB/Low Power to the OFF position.
- b. Set TIU CB1 to the OFF position.

**WARNING**

**When working inside the equipment after power has been turned off, always ground every part before touching it. Failure to do so could result in serious injury or death.**

- c. Depress pressure relief valve to equalize pressure before removing cover assembly.
- d. Release latches and remove cover assembly.
- e. Discharge capacitor to ground.
- f. Remove screws (1) and lockwashers (2) from two capacitor terminals.
- g. Remove terminal lugs (3) from capacitor terminals.
- h. Remove locknut (4) from diode.
- i. Remove terminal lug (3) from diode.
- j. Cut terminal lugs from wire as close to lug as possible.
- k. Strip wire 3/8inch (.953 cm).
- l. Insert wire in new terminal lug.
- m. Crimp terminal lug.
- n. Install terminal lugs to two capacitor terminals and secure with two screws and lockwashers.

4-11 TIU POWER SUPPLY TERMINAL LUG REPLACEMENT (MS25036-108) (CONTINUED).

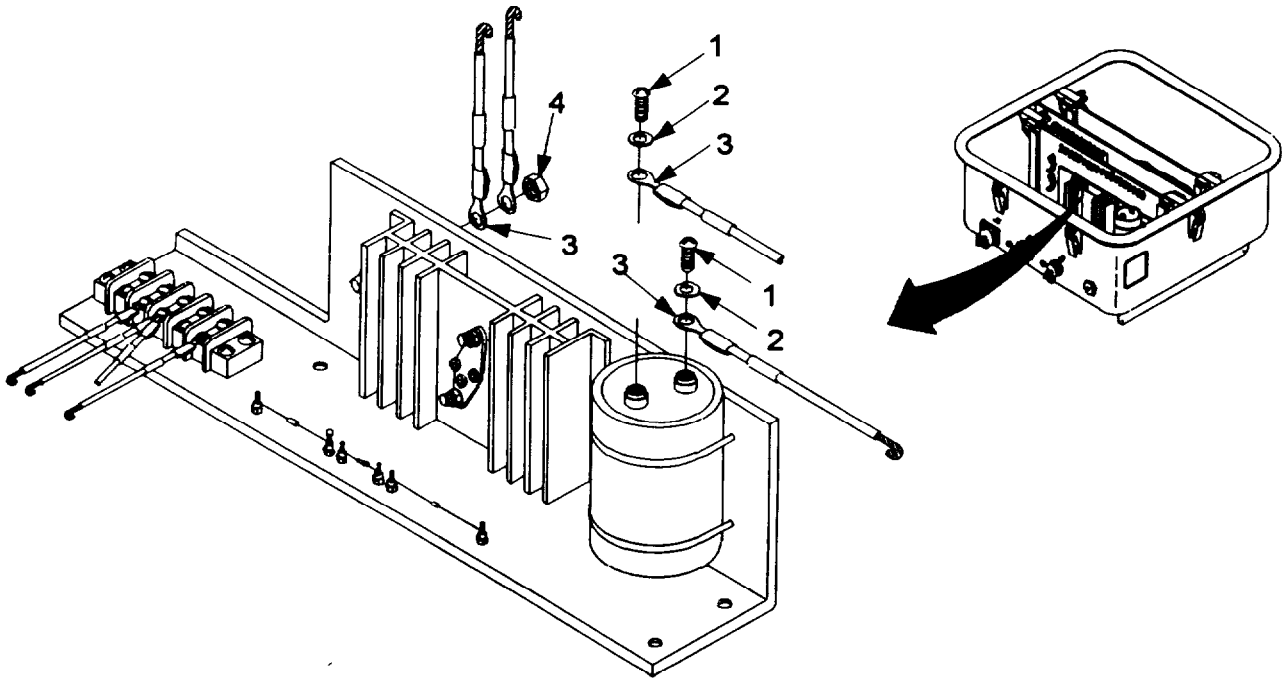

- o. Install terminal lug to diode and secure with new locknut.
- p. Apply a uniform, thin coating of grease to gasket surface.
- q. Install cover assembly and fasten latches.
- r. Set CB1 of ICB/Low Power to the ON position.
- s. Set TIU CB1 to the ON position.
- t. Test in accordance with TM 9-6920-742-14-1



**4-12 CABLE ASSEMBLY REPLACEMENT (WIO7) (9363185).****INITIAL SETUP****Materials/parts:**

Cable assembly (9363185)

**References:**

TM 9-6920-742-141

**a. Removal.**

- (1) Set CB1 of ICB/Low Power to the OFF position.
- (2) Set TIU CB1 to the OFF position.
- (3) Disconnect cable connectors P2 (1), P3 (2), and P4 (3) from supported equipment.
- (4) Disconnect cable connector P1 (4) from J3 on TIU.

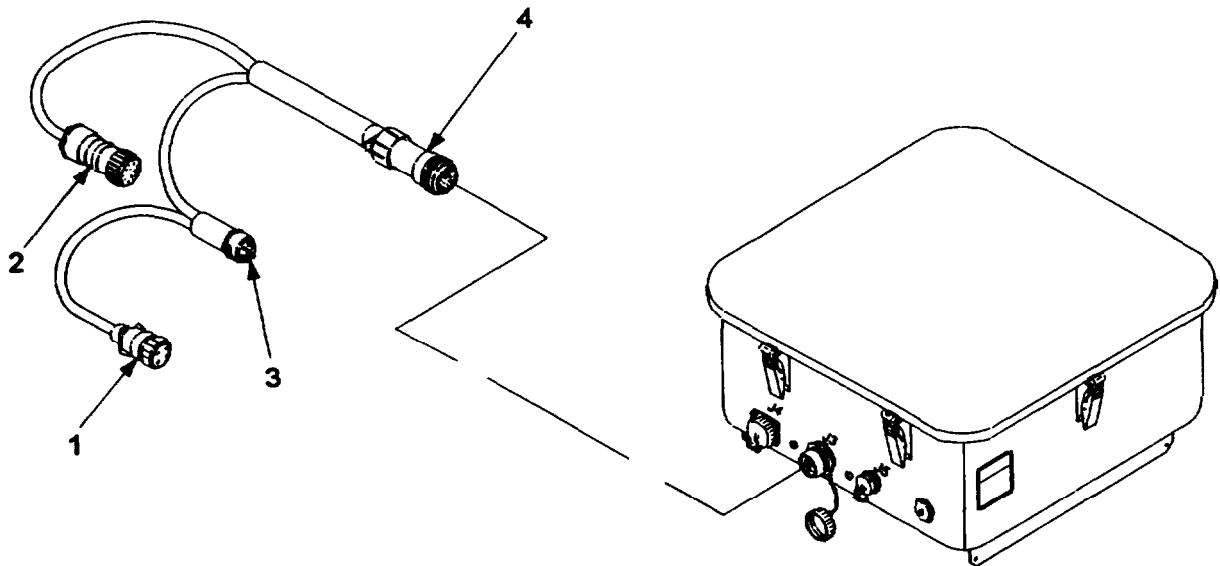
**b. Installation.**

- (1) Install cable connector P1 (4) to J3 on TIU (see FO-4).
- (2) Install cable connectors P2 (1), P3 (2), and P4 (3) to supported equipment (see FO-4).
- (3) Set CB1 of the ICB/Low Power to the ON position.
- (4) Set TIU CB1 to the ON position.
- (5) Test in accordance with FO-4.

**4-13 ICB/HIGH POWER BLOCK REPLACEMENT (TB5) (9353917).**

**INITIAL SETUP**

**Tools and Specials:**

General mechanic's automotive tool kit

**Personnel Required:**

2 persons (for safety purposes)

**Materials/Parts:**

Power block (9353917)

Power block cover (9363077)

**References:**

TM 9-6920-742-14-1

**a. Removal.**

- (1) Set CB1 on ICB/High Power to the OFF position.
- (2) Remove power from 240 vac incoming power line.

**WARNING**



When working inside the equipment after power has been turned off, always ground every part before touching it. Failure to do so could result in serious injury or death.

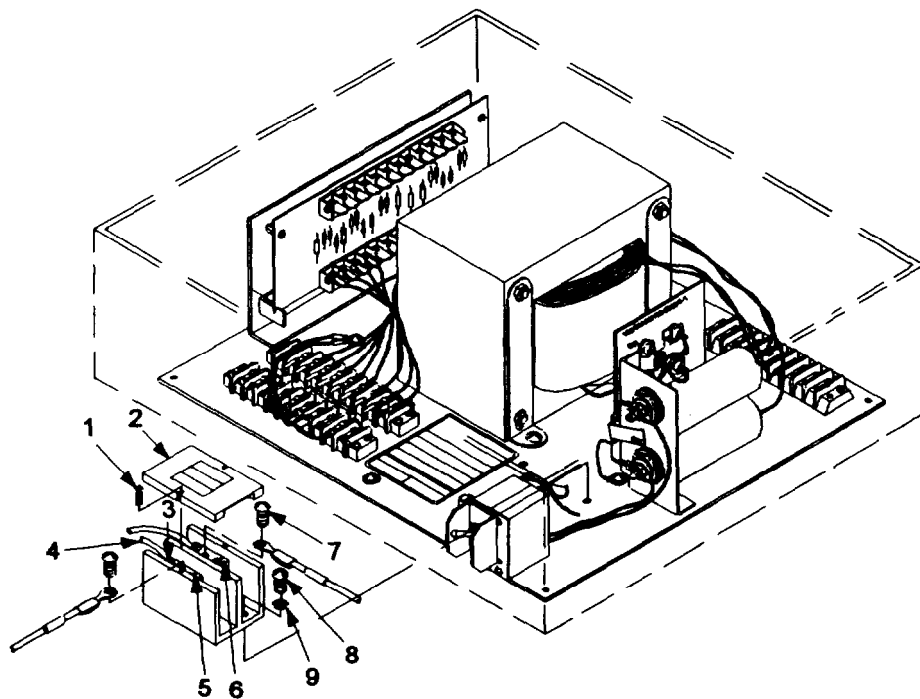

- (3) Release latches and remove cover assembly.
- (4) Remove two screws (1) and remove power block cover (2).
- (5) Loosen two screws (3), tag and remove 240 vac power line leads (4) from TB5 terminals 1 (5) and 2 (6).
- (6) Remove two screws (7) attaching CB1 line leads to TB5 terminals 1 (5) and 2 (6).
- (7) Tag and remove CB1 leads from TB5.
- (8) Remove two screws (8) and flatwashers (9) and remove TB5.

**b. Installation.**

- (1) Install TB5 to mounting plate and secure with two screws (8) and flatwashers (9).
- (2) Install two CB1 line leads to TB5 terminals 1 (5) and 2 (6) and secure with two screws (7).
- (3) Install two 240 vac power line leads (4) to TB5 and secure by tightening two screws (3).
- (4) Install power block cover (2) and secure with two screws (1).
- (5) Install cover assembly and fasten latches.
- (6) Apply power to 240 vac incoming power line.
- (7) Set CB1 on ICB/High Power to the ON position.
- (8) Test in accordance with TM 9-6920-742-14-1.

4-14 ICB/HIGH POWER CIRCUIT BREAKER ASSEMBLY REPLACEMENT (CB1) (9354038-1).

INITIAL SETUP

**Tools and Special Tools:**

General mechanic's automotive tool kit

**Personnel Required:**

2 persons (for safety purposes)

**Materials/Parts:**

Circuit breaker assembly (9354038-1)

**References:**

TM 9-6920-742-14-1

---

a. **Removal.**

- (1) Set CB1 (1) on ICB/High Power to the OFF position.
- (2) Remove power from 240 vac incoming power line.

**WARNING**



When working inside the equipment after power has been turned off, always ground every part before touching it. Failure to do so could result in serious injury or death.

- (3) Release latches and remove cover assembly.
- (4) Remove two screws and remove power block cover.

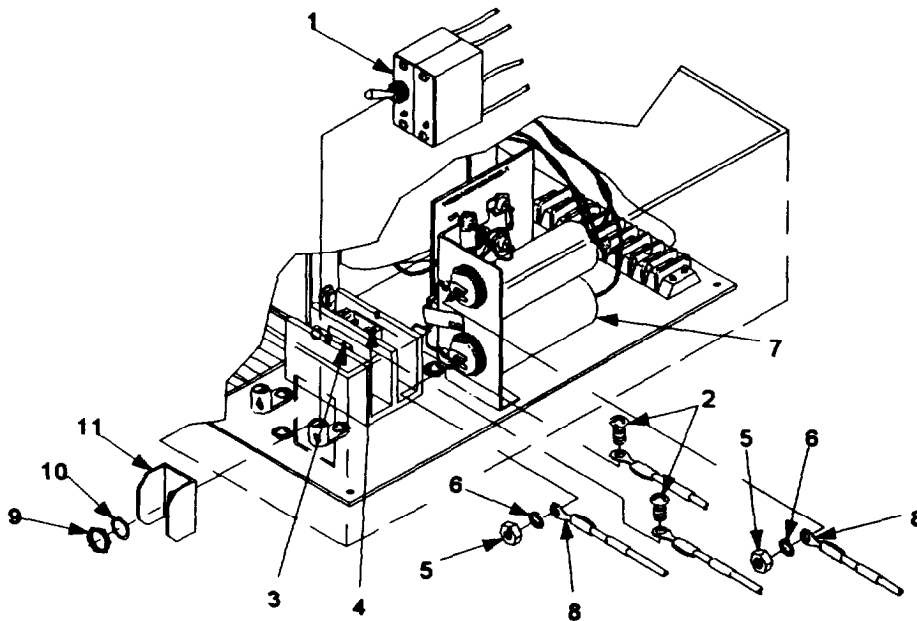

- (5) Remove two screws (2) attaching CB1 line leads to TB5 terminals 1 (3) and 2 (4).
- (6) Tag and remove CB1 leads from TB5.
- 7) Remove two nuts (5) and lockwashers (6) from input ends of EMI filters (7).
- (8) Tag and remove CB1 load leads (8) from FL1 and FL2.
- (9) Remove nut (9), washer (10), and switch guard (11).
- (10) Remove circuit breaker assembly from housing assembly.

**b. Installation.**

- (1) Install circuit breaker assembly into housing assembly.
- (2) Install switch guard (11), washer (10), and nut (9) on circuit breaker assembly.
- (3) Install CB1 load leads (8) on FL1 and FL2.

**NOTE**

**Ensure gas tube arrestor connections to FL1 and FL2 are installed before installing lockwashers and nuts.**

- (4) Install lockwashers (6) and nuts (5) on FL1 and FL2.
- (5) Install two CB1 line leads to TB5 terminals 1 (3) and 2 (4) and secure with two screws (2).
- (6) Install power block cover and secure with two screws.
- (7) Install cover assembly and fasten latches.
- (8) Apply power to 240 vac incoming power line.
- (9) Set CB1 (1) on ICB/High Power to the ON position.
- (10) Test in accordance with TM 9-6920-742-14-1.

4-15 ICB/HIGH POWER WIRING HARNESS REPLACEMENT (9354132).

INITIAL SETUP

**Tools and Special Tools:**

General mechanic's automotive tool kit

**Personnel Required:**

2 persons (for safety purposes)

**Materials/Parts:**

Wiring harness (9354132)

**References:**

TM 9-6920-742-14-1

---

**a. Removal.**

- (1) Set CB1 to the OFF position.
- (2) Remove power from 240 vac incoming power line.

**WARNING**



When working inside the equipment after power has been turned off, always ground every part before touching it. Failure to do so could result in serious injury or death.

- (3) Release latches and remove cover assembly.
- (4) Remove screws (1) from TB8 terminals 1, 2, 3, 4, 8, 9, 10, 11, and 12.

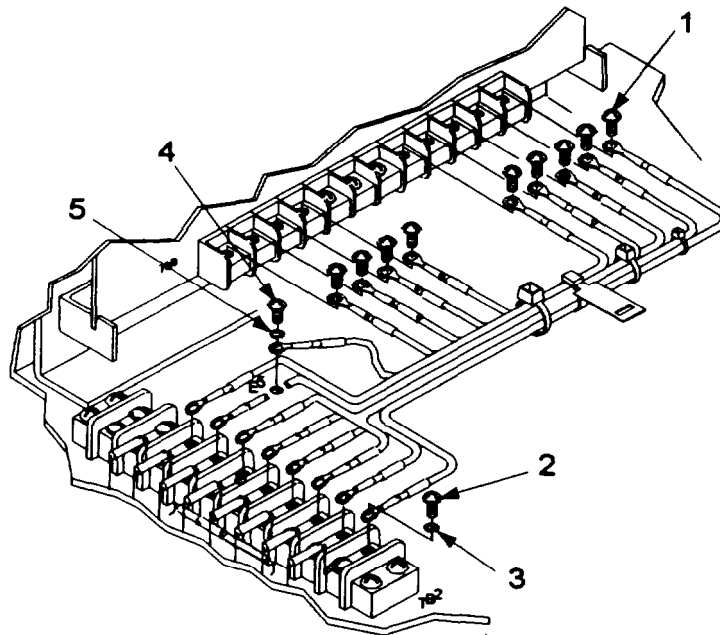

- (5) Tag and remove wiring harness leads from TB8.
- (6) Remove screws (2) and lockwashers (3) from TB2 terminals 3, 4, 5, 6, 7, 8, 9, and 10.
- (7) Tag and remove wiring harness leads from TB2.
- (8) Remove screw (4) and lockwasher (5) securing ground wire to E5.
- (9) Tag and remove wiring harness ground from E5.

**b. Installation.**

- (1) Install wiring harness ground to E5 and secure with screw (4) and lockwasher (5).
- (2) Install wiring harness leads to TB2 terminals 3, 4, 5, 6,7, 8, 9, and 10 and secure with screws (2) and lockwashers (3).
- (3) Install wiring harness leads to TB8 terminals 1,2, 3, 4, 8, 9, 10, 11, and 12 and secure with screws (1).

TB8	TB2	EARTH
1	3	
2	4	
3	5	
8	6	
9	7	
10	8	
11	9	
12	10	
4		E5

- (4) Install cover assembly and fasten latches.
- (5) Apply power to 240 vac incoming power line.
- (6) Set CB1 on ICB/High Power to the ON position.
- (7) Test in accordance with TM 9-6920-742-14-1.

**4-16 ASSEMBLY OF ICB/HIGH POWER WIRING HARNESS ASSEMBLY (9354132).**

**INITIAL SETUP**

**Tools and Special Tools:**

General mechanic's automotive tool kit  
 Wire strippers  
 Crimping tool

**Materials/Parts (Continued):**

Wire (EC22U0-2U)  
 Wire (M22759/11-16-0)  
 Tiedown strap (MS3368-1-9B)  
 Marker (9387201-8)

**Materials/Parts:**

Terminal lug (MS25036-102)  
 Terminal lug (MS25036-106)  
 Terminal lug (MS25036-153)  
 Wire (EC22U0-9U)

**References:**

Table 4-3

**Equipment Conditions:**

Wiring harness assembly removed  
 (Reference paragraph 4-15)

**NOTE**

When building cable assemblies and wiring harnesses, markers are provided for the completed assemblies. Using the same markers on small gauge wires may not be practical. Small gauge wires may be identified by reusing serviceable original wire markers, by marking the appropriate size insulation sleeving with the necessary information, or by any other practical method.

- a. Cut all lengths of wires as shown in table 4-3.
- b. Strip insulation back from all wire ends 1/4 inch (.635 cm).
- c. Install terminal lugs on wire ends as shown in table 4-3 and crimp tight.

**Table 4-3. ICB/High Power Wiring Harness Assembly (9354132).**

TERMINAL NUMBER	LUG NUMBER	LENGTH	WIRE	COLOR	TERMINAL NUMBER	LUG NUMBER
TB8-1	MS25036-102	4.00 IN. (10.2 CM)	EC22U0-9U	WHT	TB2-3	MS25036-102
TB8-2	MS25036-102	4.75 IN. (12.1 CM)	EC22U0-9U	BLK	TB2-4	MS25036-102
TB8-3	MS25036-102	5.50 IN. (14.0 CM)	EC22U0-2U	RED	TB2-5	MS25036-102
TB8-8	MS25036-102	7.38 IN. (18.7 CM)	EC22U0-9U	BLK	TB2-6	MS25036-102
TB8-9	MS25036-102	8.12 IN. (20.6 CM)	EC22U0-9U	WHT	TB2-7	MS25036-102



TERMINAL NUMBER	LUG NUMBER	LENGTH	WIRE	COLOR	TERMINAL NUMBER	LUG NUMBER
TB8-10	MS25036-102	8.88 IN. (22.6 CM)	EC22UO-9U	BLK	TB2-8	MS25036-102
TB8-11	MS25036-102	9.62 IN. (24.4 CM)	EC22UO-9U	WHT	TB2-9	MS25036-102
TB8-12	MS25036-102	10.38 IN. (26.4 CM)	EC22UO-9U	BLK	TB2-10	MS25036-102
TB8-4	MS25036-106	4.80 IN. (12.2 CM)	M22759/ 11-16-0	BLK	E5	MS25036-153

d. Arrange wires as shown in illustration, ensuring each pair has a minimum of one twist.

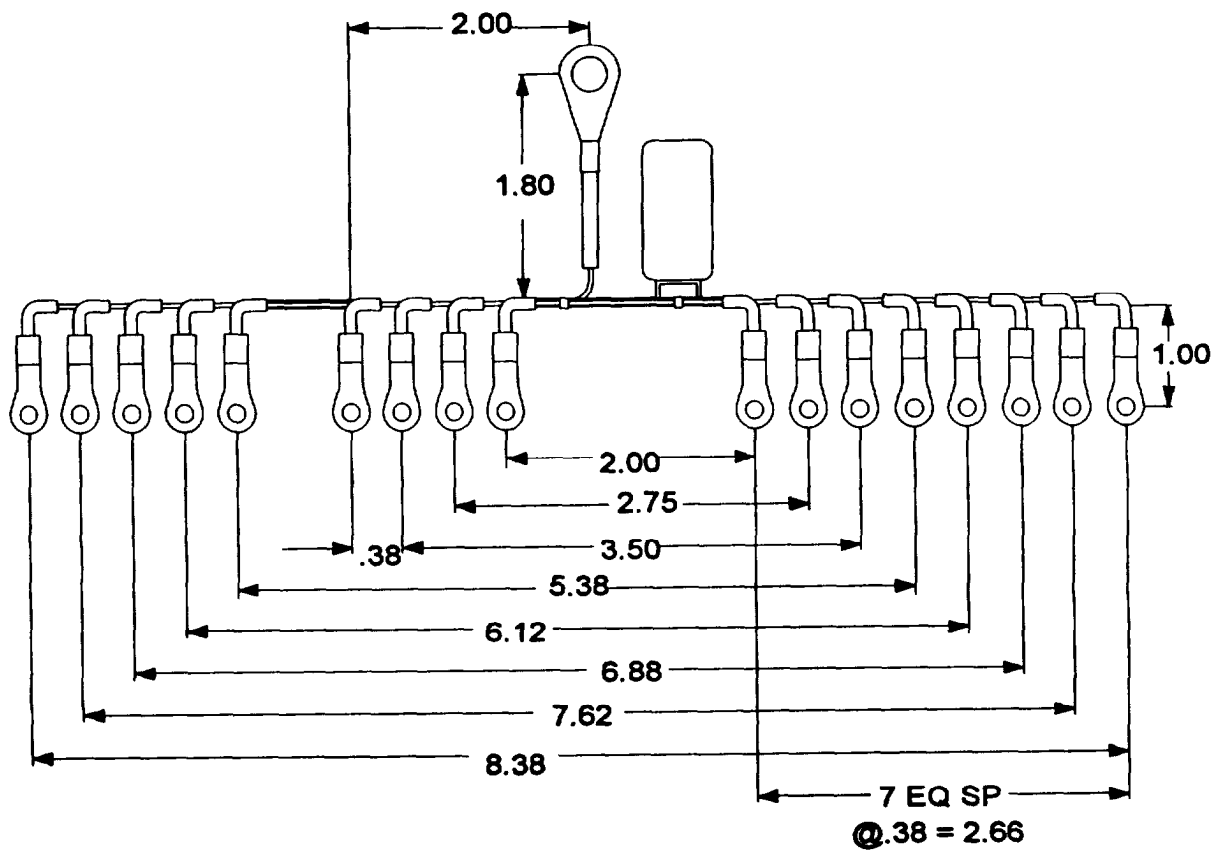

- e. Secure wiring harness with tiedown straps as required.
- f. Apply wiring harness marker.
- g. Install wiring harness assembly. Refer to paragraph 4-15.

4-17 ICB/HIGH POWER CABLE ASSEMBLY REPLACEMENT (W1O1-2) (9354096-2).

INITIAL SETUP

Materials/Parts:

Cable assembly (9354096-2)

References:

TM 9-6920-742-14-1

Personnel Required:

2 persons (for safety purposes)

---

a. Removal

- (1) Set CB1 on ICB/High Power to the OFF position.
- (2) Remove power from 240 vac incoming power line.

**WARNING**



When working inside the equipment after power has been turned off, always ground every part before touching it. Failure to do so could result in serious injury or death.

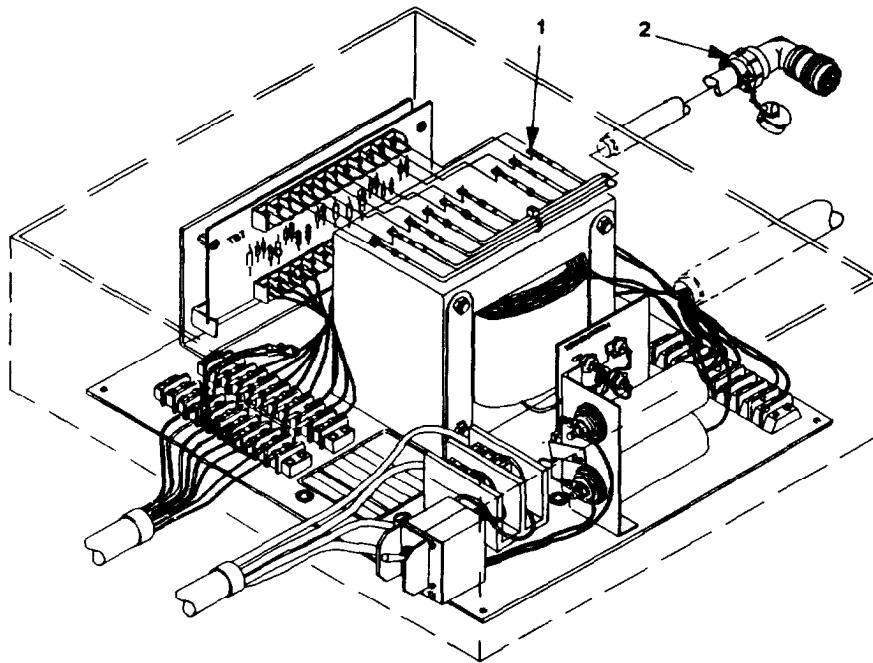

- (3) Release latches and remove cover assembly.
- (4) Remove leads from TB7 (1) terminals 3, 4, 6, 7, 8, 9, 10, 11, and 12.
- (5) Remove connector P3 (2) from J2 of IMTC and remove cable assembly.

**b. Installation.**

- (1) Install cable assembly leads (1) to TB7 terminals 3, 4, 6, 7, 8, 9, 10, 11, and 12.
- (2) Install connector P3 (2) to J2 of IMTC.
- (3) Install cover assembly and fasten latches.
- (4) Apply power to 240 vac incoming power line.
- (5) Set CB1 on ICB/High Power to the ON position.
- (6) Test in accordance with TM 9-6920-742-14-1.

**4-18 ICB/HIGH POWER CABLE ASSEMBLY REPLACEMENT (W102-2) (9354098-2).**

**INITIAL SETUP**

**Tools and Special Tools:**

General mechanic's automotive tool kit

**Personnel Required:**

2 persons (for safety purposes)

**Materials/Parts:**

Cable assembly (9354098-2)

**References:**

TM 9-6920-742-14-1

**a. Removal.**

- (1) Set CB1 on ICB/High Power to the OFF position.
- (2) Remove power from 240 vac incoming power line.

**WARNING**



**When working inside the equipment after power has been turned off, always ground every part before touching it. Failure to do so could result in serious injury or death.**

- (3) Release latches and remove cover assembly.
- (4) Remove screws (1) and lockwashers (2) from TB3 terminals 2, 3, 4, 5, 8, 9, and E4 (3).

**4-18 ICB/HIGH POWER CABLE ASSEMBLY REPLACEMENT (W102-2) (9354098-2)  
(CONTINUED).**

- (5) Tag and remove leads from TB3.
- (6) Remove connector P2 (4) from J1 of IMTC and remove cable assembly.

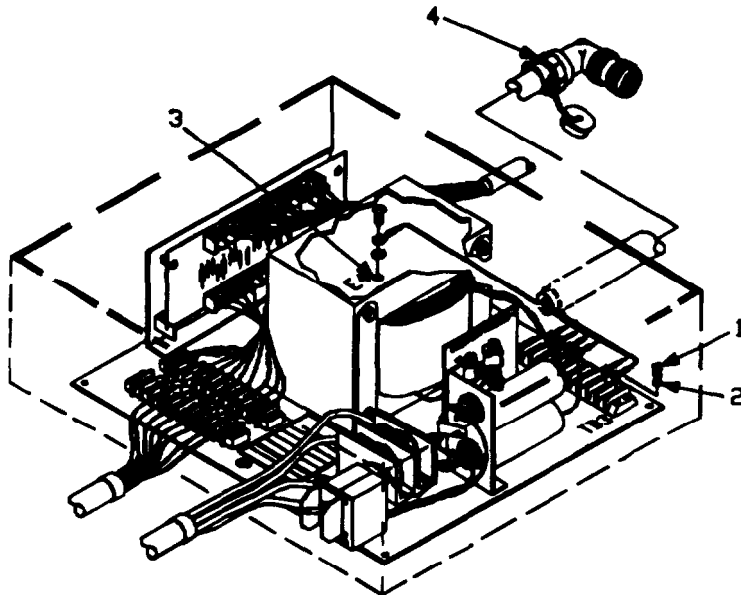

**b. Installation.**

- (1) Install cable leads to TB3 terminals 2, 3, 4, 5, 8, 9, and E4 (3) and secure with screws (1) and lockwashers (2).
- (2) Install connector P2 (4) to J1 of IMTC.
- (3) Install cover assembly and fasten latches.
- (4) Apply power to 240 vac incoming power line.
- (5) Set CB1 on ICB/High Power to the ON position.
- (6) Test in accordance with TM 9-6920-742-14-1.

4-19 ICB/LOW POWER POWER BLOCK REPLACEMENT (TB5) (9353917).

**INITIAL SETUP**

**Tools and Special Tools:**

General mechanic's automotive tool kit

**Personnel Required:**

2 person (for safety purposes)

**Materials/Parts:**

Power block (9353917)  
Power block cover (9363077)

**References:**

TM 9-6920-742-14-1

**a. Removal.**

- (1) Set CB1 (1) on ICB/Low Power to the OFF position.
- (2) Remove power from 240 vac incoming power line.

**WARNING**



When working inside the equipment after power has been turned off, always ground every part before touching it. Failure to do so could result in serious injury or death.

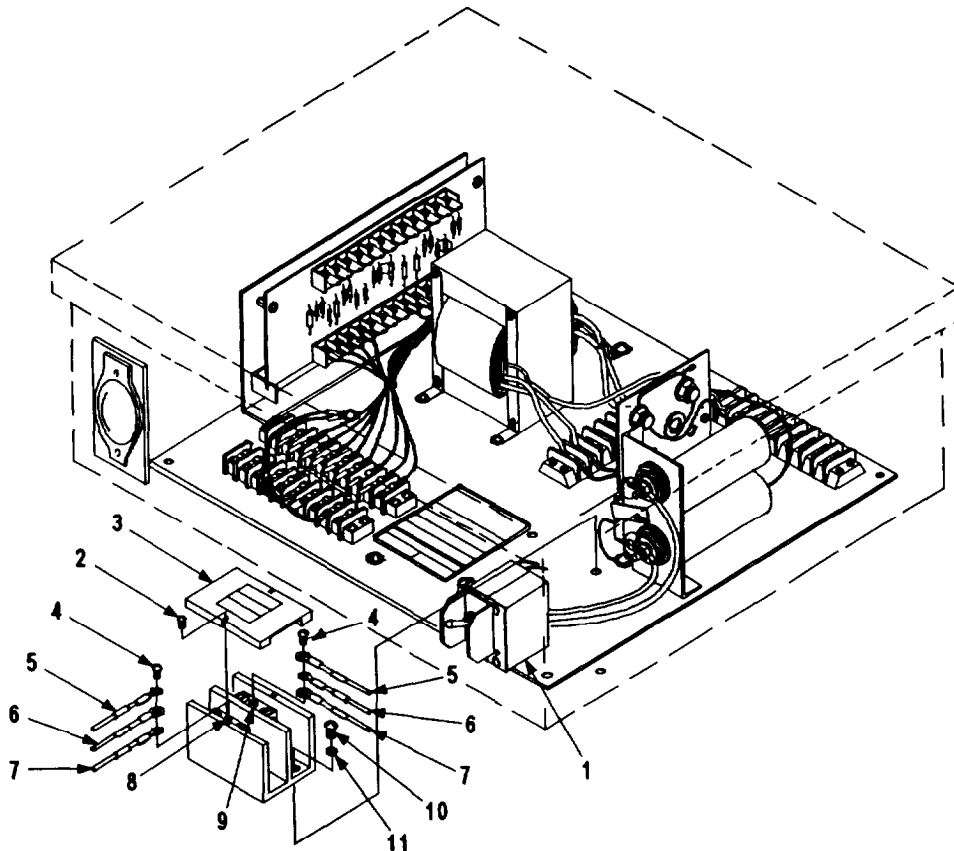

**4-19 ICB/LOW POWER POWER BLOCK REPLACEMENT (TB5) (9353917)**  
**(CONTINUED).**

- (3) Release latches and remove cover assembly.
- (4) Remove two screws (2) and remove power block cover (3).
- (5) Loosen two screws (4) tag and remove 240 vac power line leads (5), CB1 lines leads (6) and outlet receptacle leads (7) from TB5 terminals 1 (8) and 2 (9).
- (6) Remove two screws (10) and flatwashers (11) and remove TB5.

**b. Installation.**

- (1) Install TB5 to mounting plate and secure with two screws (10) and flatwashers (11).
- (2) Install two CB1 line leads (6) outlet receptable leads (7) and power line leads (5) to TB5 terminals 1 (8) and 2 (9) and secure with two screws (4).
- (3) Install power block cover (3) and secure with two screws (2).
- (4) Install cover assembly and fasten latches.
- (5) Apply power to 240 vac incoming power line.
- (6) Set CB1 (1) on ICB/Low Power to the ON position.
- (7) Test in accordance with TM 9-69260-742-14-1.

**4-20 ICB/LOW POWER CIRCUIT BREAKER ASSEMBLY REPLACEMENT (CB1)(9354038-2).**

**INITIAL SETUP**

**Tools and Special Tools:**

General mechanic's automotive tool kit

**Personnel Required:**

2 persons (for safety purposes)

**Materials/Parts:**

Circuit breaker assembly (9354038-2)

**References:**

TM 9-6920-742-14-1

**a. Removal.**

- (1) Set CB1(1) on ICB/Low Power to the OFF position.
- (2) Remove power from 240 vac incoming power

**WARNING**

**When working inside the equipment after power has been turned off, always ground every part before touching it. Failure to do so could result in serious injury or death.**

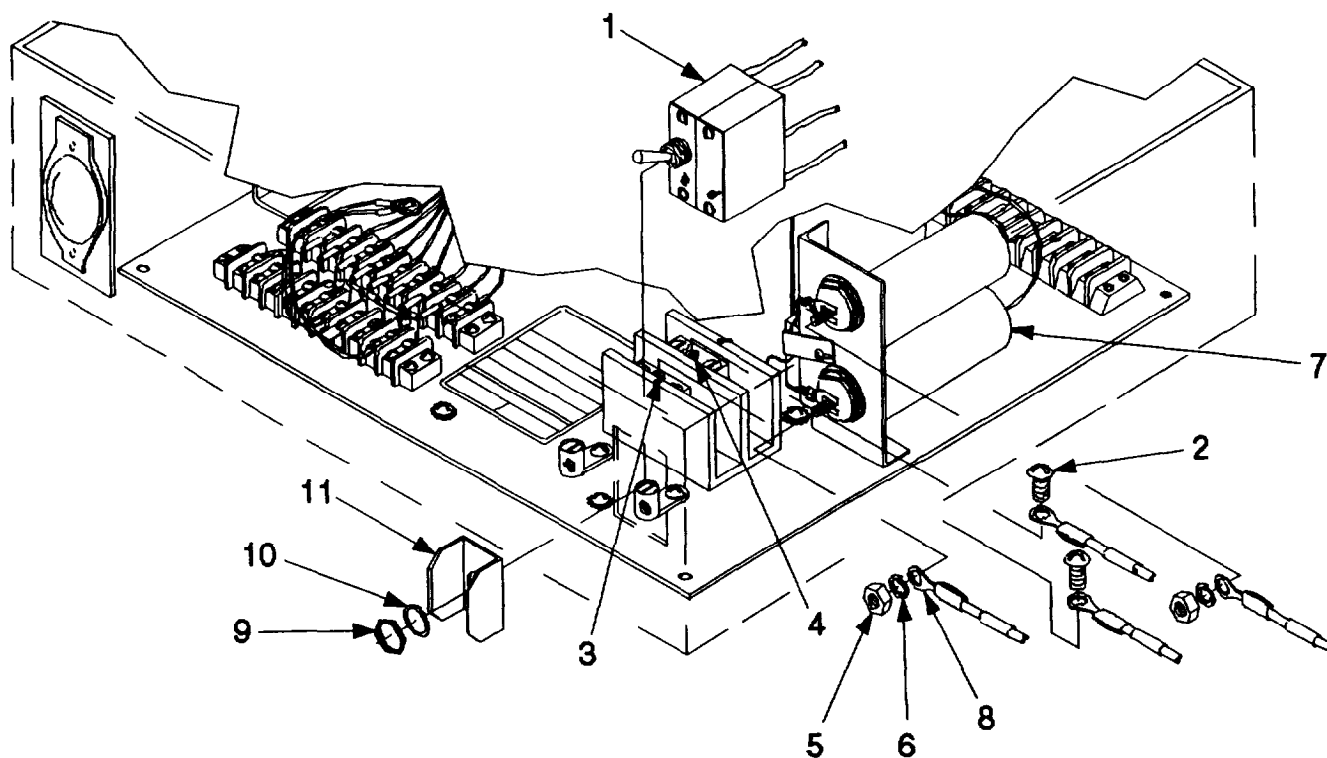

**4-20 ICB/LOW POWER CIRCUIT BREAKER ASSEMBLY REPLACEMENT (CB1)(9354038-2)  
(CONTINUED).**

- (3) Release latches and remove cover assembly.
- (4) Remove two screws and remove power block cover.
- (5) Remove two screws (2) attaching CB1 line leads to TB5 terminals 1 (3) and 2 (4).
- (6) Tag and remove CB1 leads from TB5.
- (7) Remove two nuts (5) and lockwashers (6) from input ends of EMI filters (7).
- (8) Tag and remove CB1 load leads (8) from FL1 and FL2.
- (9) Remove nut (9), washer (10), and switch guard (11).
- (10) Remove circuit breaker assembly from housing assembly.

**b. Installation.**

- (1) Install circuit breaker assembly into housing assembly.
- (2) Install switch guard ( 11) washer (10) and nut (9) to circuit breaker assembly.
- (3) Install CB1load leads (8) to FL1 and FL2 (7).

**NOTE**

**Ensure gas tube arrestor connections to FL1 and FL2 are installed before installing lockwashers and nuts.**

- (4) Install lockwashers (6) and nuts (5) to FL1 and FL2.
- (5) Install two CB1 line leads to TB5 terminals 1 (3) and 2 (4) and secure with two screws (2).
- (6) Install power block cover and secure with two screws.
- (7) Install cover assembly and fasten latches.
- (8) Apply power to 240 vac incoming power line.
- (9) Set CB1(1) on ICB/Low Power to the ON position.
- (10) Test in accordance with TM 96920-742-14-1.



4-21 ICB/LOW POWER WIRING HARNESS REPLACEMENT (93541321).

**INITIAL SETUP**

**Tools and Special Tools:**

General mechanic's automotive tool kit

**Personnel Required:**

2 persons (for safety reasons)

**Materials/Parts:**

Wiring harness assembly (9364132)

**References:**

TM 9-6920-742-14-1

**a. Removal.**

- (1) Set CB1 on ICB/Low Power to the OFF position.
- (2) Remove power from 240 vac incoming power line.

**WARNING**



When working inside the equipment after power has been turned off, always ground every part before touching it. Failure to do so could result in serious injury or death.

- (3) Release latches and remove cover assembly.
- (4) Remove screws (1) from TB8 terminals 1, 2, 3,4, 8, 9, 10, 11, and 12.

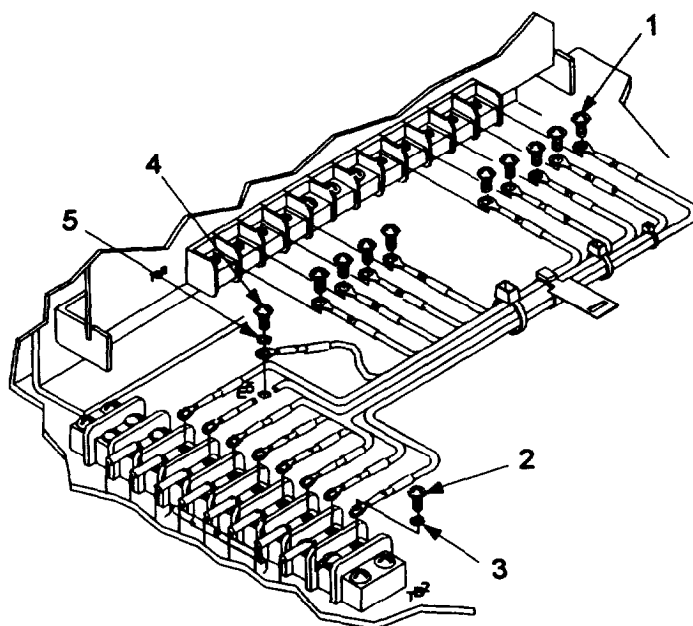

4-21 **ICB/LOW POWER WIRING HARNESS RELACEMENT (9354132) (CONTINUED).**

- (5) Tag and remove wiring harness leads from TB8.
- (6) Remove screws (2) and lockwashers (3) from TB2 terminals 3, 4,5, 6, 7,8, 9, and 10.
- (7) Tag and remove wiring harness leads from TB2.
- (8) Remove screw (4) and lockwasher (5) securing ground wire to E5.
- (9) Tag and remove wiring harness ground from E5.

b. **Installation.**

- (1) Install wiring harness ground to E5 and secure with screw (4) and lockwasher (5).
- (2) Install wiring harness leads to TB2 terminals 3,4, 5, 6, 7,8, 9, and 10 and secure with screws (2) and lockwashers (3).
- (3) Install wiring harness leads to TB8 terminals 1,2, 3, 4, 8, 9, 10, 11, and 12 and secure with screws (1).

TB8	TB2	EARTH
1	3	
2	4	
3	5	
8	6	
9	7	
10	8	
11	9	
12	10	
4		E5

- (4) Install cover assembly and fasten latches.
- (5) Apply power to 240 vac incoming power line.
- (6) Set CB1 on ICB/Low Power to the ON position.
- (7) Test in accordance with TM 9-6920-742-14-1.

**4-22 ASSEMBLY OF ICB/LOW POWER WIRING HARNESS ASSEMBLY (9354132).**

**INITIAL SETUP**

**Tools and Special Tools:**

General mechanic's automotive tool kit  
 Wire strippers  
 Crimping tool

**Materials/Parts (Continued):**

Wire (M22759/11-16-0)  
 Tiedown strap (MS3368-1-9B)  
 Marker (9387201-8)

**Materials/Parts:**

Terminal lug (MS25036-102)  
 Terminal lug (MS25036-106)  
 Terminal lug (MS25036-153)  
 Wire (EC22U0-9U)  
 Wire (EC22U0-2U)

**References:**

Table 4-4

**Equipment Conditions:**

Wiring harness assembly removed  
 (Reference paragraph 4-21)

**NOTE**

**When building cable assemblies and wiring harnesses, markers are provided for the completed assemblies. Using the same markers on small gauge wires may not be practical. Small gauge wires may be identified by reusing serviceable original wire markers, by marking the appropriate size insulation sleeving with the necessary information, or by any other practical method.**

- a. Cut all lengths of wires as shown in table 4-4.
- b. Strip insulation back from all wire ends 1/4 inch (.635 cm).
- c. Install terminal lugs on wire ends as shown in table 4-4 and crimp tight.

**Table 4-4. ICB/Low Power Wiring Harness Assembly (9354132).**

TERMINAL NUMBER	LUG NUMBER	LENGTH	WIRE	COLOR	TERMINAL NUMBER	LUG NUMBER
TB8-1	MS25036-102	4.00 IN. (10.2 CM)	EC22U0-9U	WHT	TB2-3	MS25036-102
TB8-2	MS25036-102	4.75 IN. (12.1 CM)	EC22UC-9U	BLK	TB2-4	MS25036-102
TB8-3	MS25036-102	5.50 IN. (14.0 CM)	EC22U0-2U	RED	TB2-5	MS25036-102
TB8-8	MS25036-102	7.38 IN. (18.7 CM)	EC22U0-9U	BLK	TB2-6	MS25036-102
TB8-9	MS25036-102	8.12 IN. (20.6 CM)	EC22U0-9U	WHT	TB2-7	MS25036-102

4-22 ASSEMBLY OF ICB/LOW POWER WIRING HARNESS ASSEMBLY (9354132) (CONTINUED).

Table 4-4. ICB/Low Power Wiring Harness Assembly (9354132) (Continued).

TERMINAL NUMBER	LUG NUMBER	LENGTH	WIRE	COLOR	TERMINAL NUMBER	LUG NUMBER
TB8-10	MS25036-102	8.88 IN. (22.6 CM)	EC22UO-9U	BLK	TB2-8	MS25036-102
TB8-11	MS25036-102	9.62 IN. (24.4 CM)	EC22UO-9U	WHT	TB2-9	MS25036-102
TBS-12	MS25036-102	10.38 IN. (26.4 CM)	EC22UO-9U	BLK	TB2-10	MS25036-102
Text	M S x t 106	4.80 IN	M22759/ 11-16-0	BLK	Es	MS25036- lsa .

d. Arrange wires as shown in illustration, ensuring each pair has a minimum of one twist.

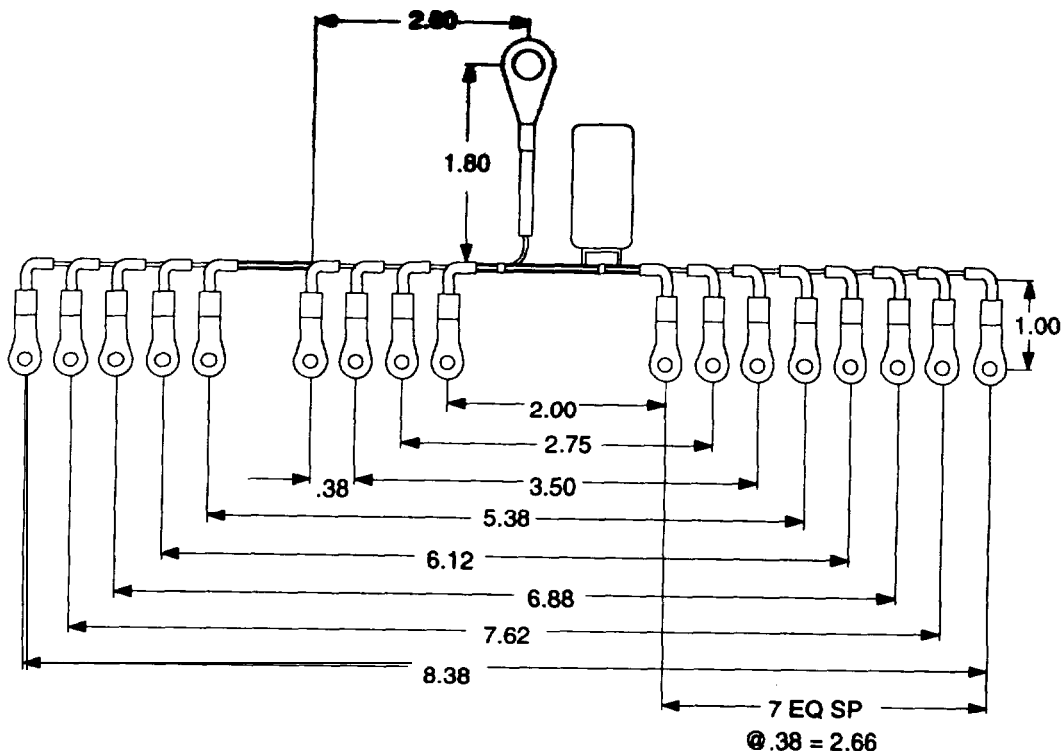

- e. Secure wiring harness with tiedown straps as required.
- f. Apply wiring harness marker.
- g. Install wiring harness assembly. Refer to paragraph 4-21.

**4-23 ICB/LOW POWER CABLE ASSEMBLY REPLACEMENT (W101-1) (9354096-1).****INITIAL SETUP****Materials/Parts:**

Cable assembly (9354096-1)

**References:**

TM 9-6920-742-14-1

**Personnel Required:**

2 persons (for safety purposes)

**a. Removal.**

- (1) Set CB1 on ICB/Low Power to the OFF position.
- (2) Remove power from 240 vac incoming power line.

**WARNING**

When working inside the equipment after power has been turned off, always ground every part before touching it. Failure to do so could result in serious injury or death.

- (3) Release latches and remove cover assembly.
- (4) Remove leads (1) from TB7 terminals 3,4, 6, 7, 8, 9, 10, 11, and 12.

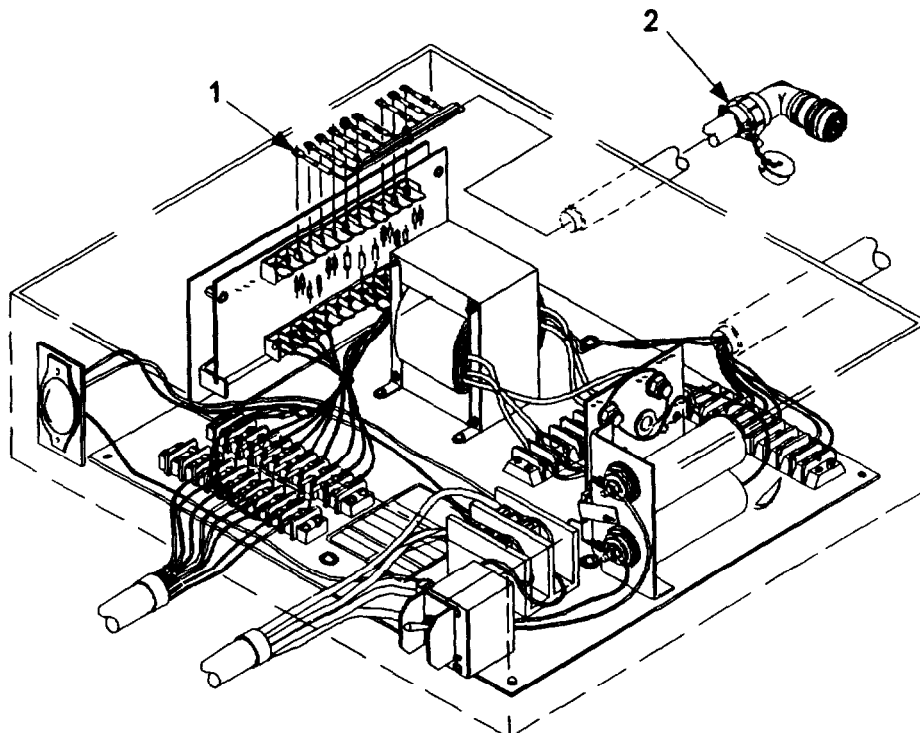

**4-23 ICB/LOW POWER CABLE ASSEMBLY REPLACEMENT (W101-1) (9354096-1)  
(CONTINUED).**

- (5) Remove connector P3 (2) from J3 of ITM or J2 of TIU and remove cable assembly.

**b. Installation.**

- (1) Install cable assembly leads (1) to TB7 terminals 3, 4, 6, 7,8, 9, 10, 11, and 12.
- (2) Install connector P3 (2) to J3 of ITM or J2 of TIU.
- (3) Install cover assembly and fasten latches.
- (4) Apply power to 240 vac incoming power line.
- (5) Set CB1 on ICB/Low Power to the ON position.
- (6) Test in accordance with TM 9-6920-742-14-1.

**4-24 ICB/LOW POWER CABLE ASSEMBLY REPLACEMENT (W101-1) (9354098-1)**

**INITIAL SETUP**

**Tools and Special Tools:**

General mechanic's automotive tool kit

**Personnel Required:**

2 persons (for safety purposes)

**Materials/Parts:**

Cable assembly (9354098-1)

**References:**

TM 9-6920-742-14-1

---

**a. Removal.**

- (1) Set CB1 on ICB/Low Power to the OFF position.
- (2) Remove power from 240 vac incoming power line.

**WARNING**

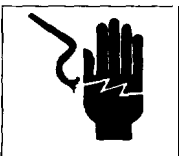

When working inside the equipment after power has been turned off, always ground every part before touching it. Failure to do so could result in serious injury or death.

- (3) Release latches and remove cover assembly.
- (4) Remove screws (1) and lockwashers (2) from TB3 terminals 2,3, 4, 5, 8, 9, and E4 (3).

- (5) Tag and remove leads from TB3 and E4.
- (8) Remove connector P1 (4) from J1 on ITM or TIU and remove cable assembly.

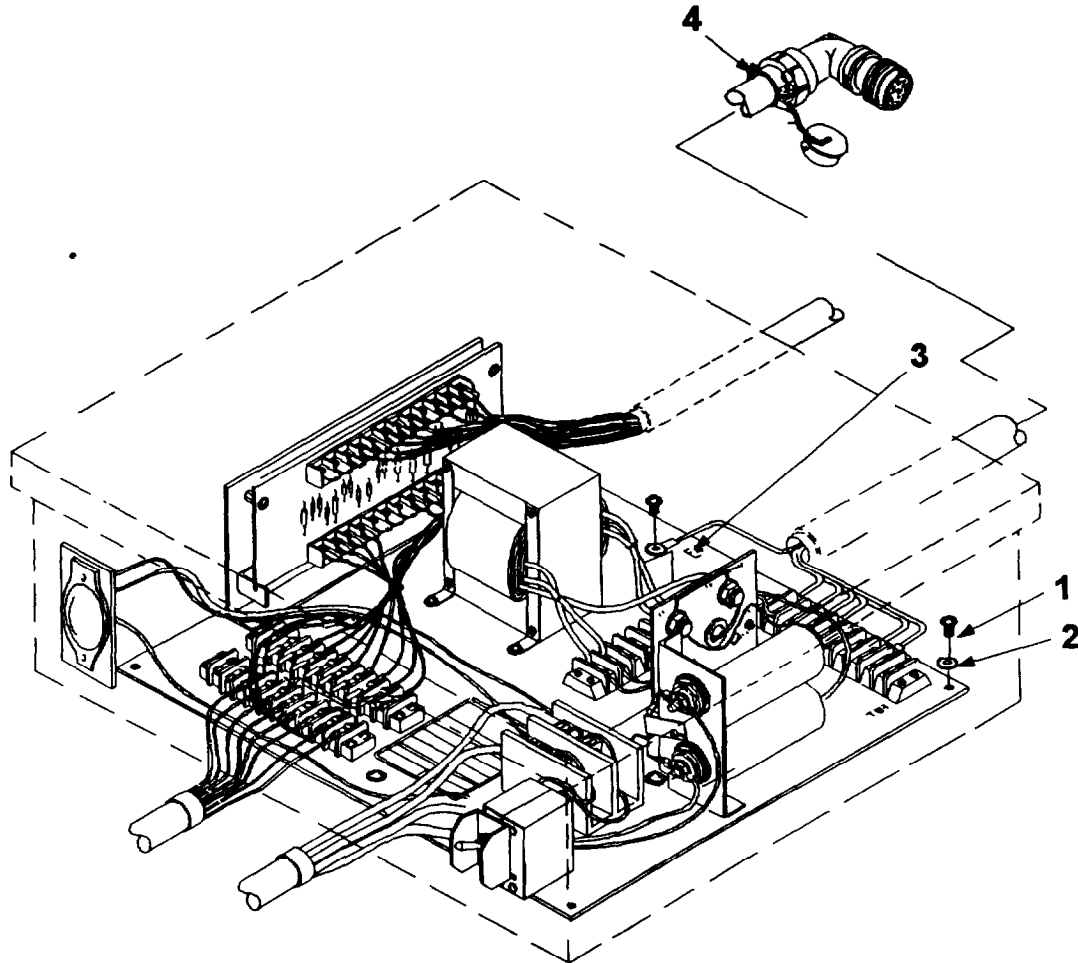

**b. Installation.**

- (1) Install cable leads to TB3 terminals 2, 3, 4, 5, 8, 9, and E4 (3) and secure with screws (1) and lockwashers (2).
- (2) Install connector P1 (4) to J1 on ITM or TIU.
- (3) Install cover assembly and fasten latches.
- (4) Apply power to 240 vac incoming power line.
- (5) Set CB1 on ICB/Low Power to the ON position.
- (6) Test in accordance with TM 9-6920-742-14-I.

4-25 ICB/LOW POWER OUTLET ASSEMBLY REPLACEMENT(12974140).

INITIAL SETUP

**Tools and Special Tools:**

General mechanic's automotive tool kit

**Personnel Required:**

2 persons (for safety purposes)

**Materials/Parts:**

Outlet assembly (12974140)

**References:**

TM 9-6920-742-14-1

---

**a. Removal.**

- (1) Set CB1 (1) on ICB/Low Power to the OFF position.
- (2) Remove power from 240 vac incoming power line.

**WARNING**



When working inside the equipment after power has been turned off, always ground every part before touching it. Failure to do so could result in serious injury or death.

- (3) Release latches and remove cover assembly.
- (4) Remove two screws and remove power block cover.
- (5) Loosen screws (2) on TB5 terminals 1 (3) and 2 (4).
- (6) Tag and remove two outlet leads (5) from TB5.
- (7) Loosen screw (6) tag, and disconnect outlet ground wire (7) from E7.
- (8) Remove outlet cover screws (8) gasket (9) and outlet cover (10) from enclosure.
- (9) Remove screws (11) and outlet (12) from enclosure.

**b. Installation.**

- (1) Set CB1 (1) on ICB/Low Power to the OFF position.
- (2) Install outlet (12) and screws (11) in housing assembly.
- (3) Install gasket (9) and outlet cover (10) to housing assembly with *screws (8)*.



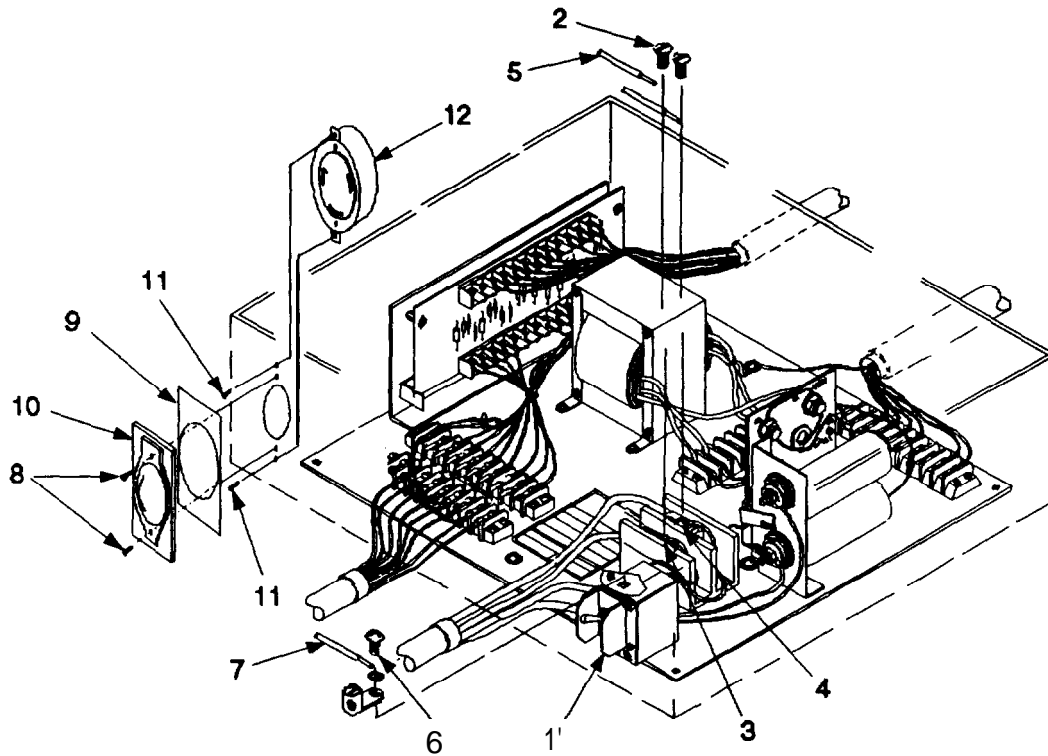

- (4) Connect CB2 ground wire (7) to E7 and tighten screw (6).

**NOTE**

**Ensure two CB1 line leads are in place in TB5 terminals prior to installing screws securing CB2 line leads.**

- (5) Connect two outlet leads (5) to TB5 terminals 1 (3) and 2 (4) and tighten screws (2).
- (6) Install power block cover and secure with two screws.
- (7) Install cover assembly and fasten latches.
- (8) Apply power to 240 vac incoming power line.
- (9) Set CB1 on ICB/Low Power to the ON position.
- (10) Test in accordance with TM 9-6920-742-14-1.



**CHAPTER 5**

**DIRECT SUPPORT MAINTENANCE INSTRUCTIONS**

**SECTION I. TROUBLESHOOTING PROCEDURES**

**5-1 TROUBLESHOOTING PROCEDURES.**

Table 5-1 lists the common malfunctions that you may find during operation or maintenance of the Interconnecting Box, Target Interface (TIU); interconnecting Box, High Power (ICB/High Power); and Interconnecting Box, Low Power (ICB/Low Power). You should perform the tests/inspections and corrective actions in the order listed. Before you begin troubleshooting, ensure that unit PMCS have been performed. The following procedures are based on the premise that unit PMCS have been completed. If in doubt, perform PMCS in accordance with procedures described in table 4-1. This manual cannot list all the malfunctions that may occur nor all the tests or inspections and corrective actions. Notify your supervisor if a malfunction persists and cannot be corrected by prescribed action.

**WARNING**

Personnel working with or near high voltages must be trained and certified in mouth-to-mouth and cardiopulmonary resuscitation. Installation medical activities shall provide certified instructors. Newly assigned maintenance personnel must be trained as soon as practical.

Make sure at least two persons are in the area at all times when work is being performed on exposed live circuits carrying 30 volts or more.

**Malfunction Index**

	Malfunction
<b>TIU</b>	
TIU internal power malfunction	1
TIU does not respond to mover commands	2
<b>ICB/High Power</b>	
Simulator or target mechanism connected to ICB/High Power does not respond to RCS commands	3
<b>ICB/Low Power</b>	
Simulator or target mechanism connected to ICB/Low Power does not respond to RCS commands	4

Table 5-1. Direct Support Troubleshooting Procedures.

MALFUNCTION	TEST OR INSPECTION	CORRECTIVE ACTION
-------------	--------------------	-------------------

1. TIU internal power malfunction.

**WARNING**

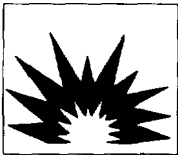

Disarm, then disconnect the GUFs from TIU. The GUFs must be disconnected before performing maintenance. Explosion is possible and can cause personal injury and damage to equipment. Pyrotechnics are used during range operation.

**WARNING**



High voltages are present inside the equipment. Death or injury from electric shock may result from failure to observe safety precautions.

Step 1. Remove power. Remove control logic CCA in accordance with paragraph 5-3. Using multimeter, check for continuity by placing red lead on A1TB1 terminal 7 and black lead on A1TB1 terminal 3. Multimeter should indicate continuity. Reverse multimeter leads. Multimeter should indicate no continuity.

If readings are correct, proceed to step 2.

If readings are incorrect, replace TIU suppressor assembly in accordance with paragraph 5-8.

Step 2. Install control logic CCA in accordance with paragraph 5-3. Position RCS Adapter controls prior to application of power. Refer to TM 9-6920-742-14-1.

Step 3. Perform RCS Adapter internal test procedures. Refer to TM 9-6920-742-14-1.

Step 4. Connect test cable PN 9387319 P1 to RCS adapter J1, P2 to UUT J2, and P3 to UUT J3.

Step 5. Connect power cable PN 9387315 P1 to RCS adapter J3, and P2 to UUT J1.

Step 6. Set RCS adapter TARGET ADDRESS switches to the same address as the UUT.

Step 7. Set the RCS adapter Mode Control POWER switch to ON, the RCS adapter UUT POWER to ON, and UUT CB1 to ON.

Table 5-1. Direct Support Troubleshooting Procedures (Continued).

MALFUNCTION	TEST OR INSPECTION	CORRECTIVE ACTION
Step 8.	Set RCS adapter RUN/PAUSE switch to RUN. Press and release SINGLE CYCLE pushbutton.	
Step 9.	Set RCS adapter CMD TEST/OPERATING switch to OPERATING. The serial status display START BIT, PREAMBLE, and TRAILING ONE'S lamps should illuminate.	
	If lamps illuminate, proceed to step 16.	
	If lamps do not illuminate, proceed to step 10.	
Step 10.	With CB1 in the ON position, place multimeter red lead on A1TB1 terminal 1 and black lead on A1TB1 terminal 7 (see ). Multimeter should indicate $24\pm 3$ vdc.	
	If reading is correct, proceed to step 11.	
	If reading is incorrect, place CB1 in the OFF position. Remove P2 from J1 of TIU and use multimeter to check for continuity from J1 pin D to A1TB1 terminal 1 and from J1 pin H to A1TB1 terminal 7. If continuity is found refer to ICB/Low Power troubleshooting. If continuity is not found repair wiring or replace J1 in accordance with paragraph 5-12 and repeat step 10.	
Step 11.	With CB1 in the ON position, place multimeter red lead on A1TB1 terminal 4 and black lead on A1TB1 terminal 8 (see ). Multimeter should indicate $24\pm 3$ vdc.	
	If reading is correct, proceed to step 12.	
	If reading is not correct, replace circuit breaker assembly in accordance with paragraph 5-11 and repeat step 11.	
Step 12.	With CB1 in the ON position, place multimeter red lead on A2TB1 terminal 1 and black lead on terminal 4. Multimeter should indicate $24\pm 3$ vdc	
	If multimeter indication is correct, proceed to step 13.	
	If multimeter indication is not correct, repair wiring or replace wiring harness in accordance with paragraph 5-10 and repeat step 12.	
Step 13.	With CB1 in the ON position, place multimeter red lead on A2TB1 terminal 3 and black lead ground. Multimeter should indicate $12\pm 1.5$ vdc.	
	If multimeter indication is correct, proceed to step 14.	
	If multimeter indication is not correct, replace power supply in accordance with paragraph 4-8 and repeat step 13.	

Table 5-1. Direct Support Troubleshooting Procedures (Continued).

MALFUNCTION	TEST OR INSPECTION	CORRECTIVE ACTION
-------------	--------------------	-------------------

Step 14. With CB1 in the ON position, place multimeter red lead on control logic circuit card TP1 (red) and black lead on TP2 (black). Multimeter should indicate  $10 \pm 1$  vdc.

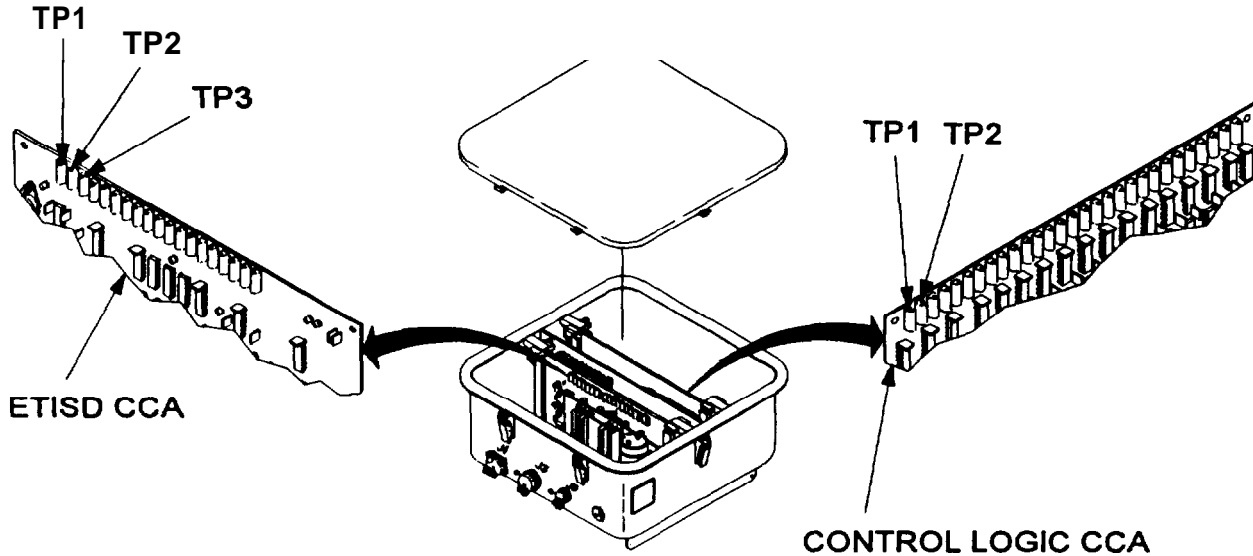

If multimeter indication is correct, proceed to step 14.

If multimeter indication is not correct, remove power. Remove control logic CCA in accordance with paragraph 5-3. Using multimeter check for continuity between XA1-31 and A1TB1 terminal 4 (see FO-1). If continuity is not found, repair wiring or replace wiring harness in accordance with paragraph 5-10, or replace connector XA1 in accordance with paragraph 5-16. If continuity is found, replace control logic CCA in accordance with paragraph 5-3 and repeat step 14.

Step 15. With CB1 in the ON position, place multimeter red lead on ETISD TP1 (red) and black lead on ground. Multimeter should indicate  $24 \pm 3$  vdc.

If multimeter indication is correct proceed to step 16.

If multimeter indication is not correct, remove power. Remove ETISD in accordance with paragraph 5-4. Using multimeter check for continuity between XA2-31 and A1TB1 terminal 4. Also check continuity between A1TB1 terminal 7 and XA2 pins 30 and 65. If continuity is not found repair wiring, replace wiring harness in accordance with paragraph 5-10, or replace connector XA2 in accordance with paragraph 5-20. If continuity is found replace ETISD CCA in accordance with paragraph 5-4 and repeat step 15.

Table 5-1. Direct Support Troubleshooting Procedures (Continued).

**MALFUNCTION**  
**TEST OR INSPECTION**  
**CORRECTIVE ACTION**

Step 16. With CB1 in the ON position, place multimeter red lead on ETISD TP3 (green) and black lead on TP3 (black). Multimeter should indicate  $10 \pm 1$  vdc.

If multimeter indication is correct, proceed to step 17.

If multimeter indication is not correct, remove power. Replace ETISD in accordance with paragraph and repeat step 16.

Step 17. Set RCS adapter UUT POWER switch to OFF. Disconnect test cable connectors J2 and J3 on the UUT. Set UUT POWER switch to ON. Using multimeter, check for voltage between: UUT connector J2 pin m (red lead) and J2 pin r (black lead). Multimeter should indicate  $24 \pm 3$  vdc. UUT connector J4 pin K (red lead) and J4 pin A (black lead). Multimeter should indicate  $12 \pm 1.5$  vdc. UUT connector J3 pin q (red lead) and J3 pin r (black lead). Multimeter should indicate  $12 \pm 1.5$  vdc.

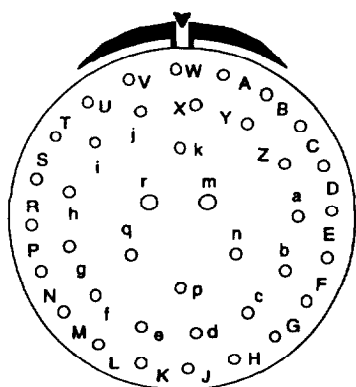

J2

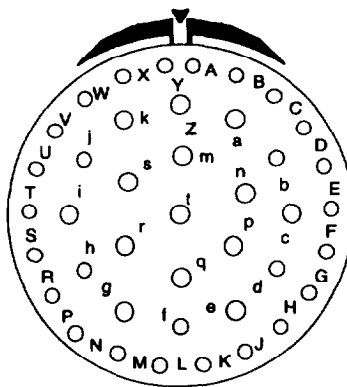

J3

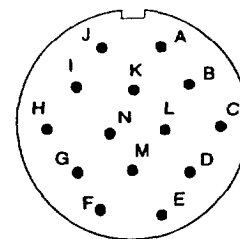

J4

If multimeter indications are correct, UUT internal power is operational. Reconnect test cables and proceed to malfunction 2.

If multimeter indication is not correct, remove power. Check internal wiring for obvious damage and for continuity (refer to FO-1). Repair wiring as necessary or replace wiring harness in accordance with paragraph 5-10 or replace J4 wiring harness in accordance with paragraph 5-21 and repeat step 17.

Table 5-1. Direct Support Troubleshooting Procedures.

---

MALFUNCTION
TEST OR INSPECTION
CORRECTIVE ACTION

---

2. TIU does not respond to mover commands.

**WARNING**

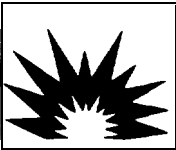

Disarm, then disconnect the GUFFS from TIU. The GUFFS must be disconnected before performing maintenance. Explosion is possible and can cause personal injury and damage to equipment. Pyrotechnics are used during range operation.

**WARNING**



High voltages are present inside the equipment. Death or injury from electric shock may result from failure to observe safety precautions.

- Step 1. Position RCS Adapter controls prior to application of power. Refer to TM 9-6920-742-I.
- Step 2. Perform RCS Adapter internal test procedures. Refer to TM 9-6920-742-14-1.
- Step 3. Connect test cable PN 9387319 P1 to RCS adapter J1, P2 to UUT J2, and P3 to UUT J3.
- Step 4. Connect power cable PN 9387315 P1 to RCS adapter J3, and P2 to UUT J1.
- Step 5. Set RCS adapter TARGET ADDRESS switches to the same address as the UUT.
- Step 6. Place RCS adapter switches in the following positions:
  - Mode Control POWER to ON
  - UUT POWER to ON
  - RUN/PAUSE switch to RUN
  - SINGLE CYCLE press and release
  - CMD TEST to OPERATING
  - Target Controls COMMAND to COMMAND,
- Step 7. Set UUT CB1 to ON.



**Table 5-1 Direct Support Troubleshooting Procedures (Continued).**

<b>MALFUNCTION</b>	<b>TEST OR INSPECTION</b>	<b>CORRECTIVE ACTION</b>
	Step 8. Set RCS adapter mover controls SPEED control to STOP. TIU Response Monitor STOP lamp is illuminated.	
	Step 9. Set RCS adapter SPEED control to SPEED 1 through 4. The corresponding lamp should illuminate and all other SPEED lamps should be extinguished.	
		If SPEED lamps illuminate, Mover Speed circuits are operational. Proceed to step 11.
		If lamps do not illuminate correctly, proceed to step 10.
	Step 10. Using multimeter, place negative lead to ETISD TP3 (black), and positive lead to the following test points listed below on the card. Set the RCS adapter SPEED selector switch to the following points and observe multimeter indications.	
		TP13 - SPEED 4 - 2 +I vdc
		TP14 - SPEED 2 - 2 fl vdc
		TP15 - STOP - 2 +I vdc
		TP16 - SPEED 1 - 2 +I vdc
		TP17 - SPEED 3 - 2 fl vdc
		If multimeter indication is correct, remove power and test continuity of wiring between ETISD connector XA2 and UUT J3 (see FO-1). Repair wiring, replace wiring harness in accordance with paragraph 5-10, or replace connector XA2 in accordance with paragraph 5-20 and repeat step 10. If continuity is found, replace ETISD CCA in accordance with paragraph 5-4 and repeat step 10.
		If multimeter indication is not correct, remove power and check continuity between UUT J2 connector and control logic CCA connector XAI (see FO-1). If continuity is found, replace control logic CCA in accordance with paragraph 5-3 and repeat step 10. If continuity is not found, repair wiring, replace wiring harness in accordance with paragraph 5-10, or replace connector XAI in accordance with paragraph 5-16 and repeat step 10.
	Step 1 I. Set RCS adapter SPEED control to STOP. Set limit simulator FWD LIMIT/OFF/REV LIMIT switch to REV LIMIT. Serial status display REV lamp should illuminate.	
		If REV lamp illuminates, proceed to step 14.
		If REV lamp fails to illuminate, remove power. Replace control logic CCA in accordance with paragraph 5-3. Restore power and repeat step 11.
		If lamp still fails to illuminate, remove power. Install original control logic CCA to UUT in accordance with paragraph 5-3. Replace ETISD CCA in accordance with paragraph 5-4 and repeat step 11.
		If lamp still fails to illuminate, proceed to step 12.

Table 5-1. Direct Support Troubleshooting Procedures (Continued).

MALFUNCTION	TEST OR INSPECTION	CORRECTIVE ACTION
-------------	--------------------	-------------------

Step 12. Remove control logic CCA in accordance with paragraph . Remove ETISD CCA in accordance with paragraph 5-4. Using multimeter, check for continuity from:

- XA2 pin 45 to J3 pin M
- XA2 pin 1 to XA1 pin 1
- XA1 pin 33 to J2 pin h

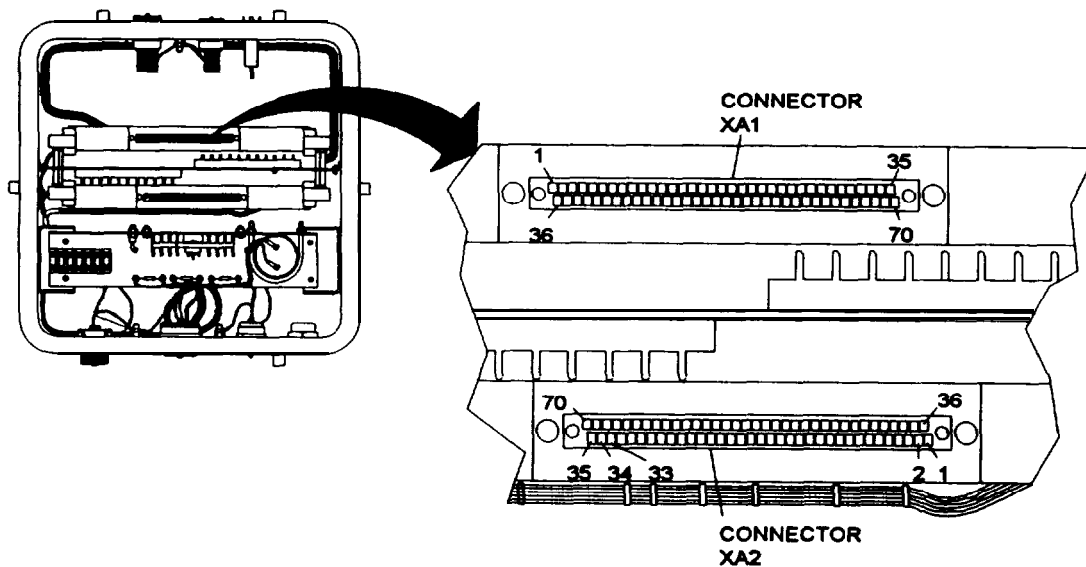

If continuity is not found, repair wiring as necessary, replace wiring harness in accordance with paragraph 5-10, or replace connector XA1 in accordance with paragraph 5-16, or replace connector XA2 in accordance with paragraph 5-20, or replace connector J3 in accordance with paragraph 5-14, or replace connector J2 in accordance with paragraph 5-13 and repeat step 12.

If continuity is found, install CCAs, reconnect cable connectors and reattach RCS adapter, place RCS power and UUT power circuit breakers in the ON position and proceed to step 13.

Step 13. Set RCS adapter FWD/LIMIT/OFF/REV LIMIT switch to FWD LIMIT. Serial status display FWD lamp should illuminate and REV lamp should extinguish.

If FWD lamp illuminates and REV lamp extinguishes, proceed to step 15.

If FWD lamp fails to illuminate and/or REV lamp fails to extinguish, remove power. Replace control logic CCA in accordance with paragraph 5-3. Restore power and repeat step 13.

Table 5-1. Direct Support Troubleshooting Procedures (Continued).

MALFUNCTION	TEST OR INSPECTION	CORRECTIVE ACTION
		<p>If FWD lamp still fails to illuminate and/or REV lamp still fails to extinguish, remove power. Install original control logic CCA to UUT in accordance with paragraph 5-3. Replace ETISD CCA in accordance with paragraph 5-4 and repeat step 13.</p> <p>If FWD lamp still fails to illuminate and/or REV lamp still fails to extinguish, proceed to step 14.</p>
	Step 14.	<p>Remove control logic CCA in accordance with paragraph 5-3. Remove ETISD CCA in accordance with paragraph 5-4. Using multimeter, check for continuity from:</p> <p style="padding-left: 40px;">XA2 pin 46 to J3 pin L            XA2 pin 2 to XA1 pin 2            XA1 pin 33 to J2 pin h</p> <p>If continuity is not found, repair wiring as necessary, replace wiring harness in accordance with paragraph 5-10, or replace connector XA1 in accordance with paragraph 5-16, or replace connector XA2 in accordance with paragraph 5-20, or replace connector J3 in accordance with paragraph 5-14, or replace connector J2 in accordance with paragraph 5-13 and repeat step 14.</p> <p>If continuity is found, install CCAs, reconnect RCS adapter, place RCS power and UUT power circuit breakers in the ON position and proceed to step 15.</p>
	Step 15.	<p>Set RCS adapter FWD/LIMIT/OFF/REV LIMIT switch to OFF. Set RCS adapter FORWARD/OFF/REVERSE switch to REVERSE. TIU response monitor REV lamp should illuminate after one second.</p> <p>If lamp illuminates, proceed to step 17.</p> <p>If lamp does not illuminate, remove power. Replace control logic CCA in accordance with paragraph 5-3. Restore power and repeat step 15.</p> <p>If lamp still fails to illuminate, remove power. Install original control logic CCA to UUT in accordance with paragraph 5-3. Replace ETISD CCA in accordance with paragraph 5-4 and repeat step 15.</p> <p>If lamp still fails to illuminate, remove power. Proceed to step 16.</p>

**Table 5-1. Direct Support Troubleshooting Procedures (Continued).**

**MALFUNCTION**

**TEST OR INSPECTION**

**CORRECTIVE ACTION**

Step 16. Remove control logic CCA in accordance with paragraph 5-3. Remove ETISD CCA in accordance with paragraph 5-4. Using multimeter, check for continuity from:

- XA1 pin 47 to XA2 pin 47
- XA2 pin 42 to J3 pin K

If continuity is not found, repair wiring as necessary replace wiring harness in accordance with paragraph 5-10, replace connector XA1 in accordance with paragraph 5-16, replace connector XA2 in accordance with paragraph 5-20, or replace connector J3 in accordance with paragraph 5-14 and repeat step 16.

If continuity is found, proceed to step 17.

Step 17. Set RCS adapter FORWARD/OFF/REVERSE switch to FORWARD. The TIU response monitor FWD lamp should illuminate after one second.

If FWD lamp illuminates, proceed to step 19.

If FWD lamp does not illuminate, remove power. Replace control logic CCA in accordance with paragraph 5-3. Restore power and repeat step 17.

If FWD lamp still fails to illuminate, remove power. Install original control logic CCA to UUT in accordance with paragraph 5-3. Replace ETISD CCA in accordance with paragraph 5-20 and repeat step 17.

If FWD lamp still fails to illuminate, remove power. Proceed to step 18.

Step 18. Remove control logic CCA in accordance with paragraph 5-3. Remove ETISD CCA in accordance with paragraph 5-4. Using multimeter, check for continuity from:

- XA1 pin 49 to XA2 pin 49
- XA2 pin 44 to J3 pin J

If continuity is not found, repair wiring as necessary, replace wiring harness in accordance with paragraph 5-10, replace connector XA1 in accordance with paragraph 5-16, replace connector XA2 in accordance with paragraph 5-20, or replace connector J3 in accordance with paragraph 5-14 and repeat step 18.

If continuity is found, proceed to step 19.

Step 19. Set RCS adapter UP LIMIT/OFF/DOWN LIMIT switch to DOWN LIMIT. Serial status display DWN lamp should illuminate.

If DWN lamp illuminates, proceed to step 21.

Table 5-1. Direct Support Troubleshooting Procedures (Continued).

MALFUNCTION	TEST OR INSPECTION	CORRECTIVE ACTION
		<p>If DWN lamp does not illuminate, remove power. Replace control logic CCA in accordance with paragraph 5-3. Restore power and repeat step 19.</p> <p>If DWN lamp still fails to illuminate, remove power. Install original control logic CCA to UUT in accordance with paragraph 5-3. Replace ETISD CCA in accordance with paragraph 5-4 and repeat step 19.</p> <p>If DWN lamp still fails to illuminate, remove power. Proceed to step 20.</p>
		<p>Step 20. Remove control logic CCA in accordance with paragraph 5-3. Remove ETISD CCA in accordance with paragraph 5-4. Using multimeter, check for continuity from:</p> <p style="padding-left: 40px;">XA2 pin 51 to J3 pin h XA2 pin 50 to A1TB2-4 XA1 pin 39 to A1TB2-4</p> <p>If continuity is found, proceed to step 21.</p> <p>If continuity is not found, repair wiring as necessary, replace wiring harness in accordance with paragraph 5-10, replace connector XA1 in accordance with paragraph 5-16, replace connector XA2 in accordance with paragraph 5-20, or replace connector J3 in accordance with paragraph 5-14 and repeat step 20.</p>
		<p>Step 21. Set RCS adapter target controls UP/DOWN switch to UP. TIU response monitor UP lamp should illuminate.</p> <p>If UP lamp illuminates, proceed to step 23.</p> <p>If UP lamp does not illuminate, remove power. Replace control logic CCA in accordance with paragraph 5-3. Restore power and repeat step 21.</p> <p>If UP lamp still fails to illuminate, remove power. Install original control logic CCA to UUT in accordance with paragraph 5-3. Replace ETISD CCA in accordance with paragraph 5-4 and repeat step 21.</p> <p>If UP lamp still fails to illuminate, remove power. Proceed to step 22.</p>

**Table 5-1. Direct Support Troubleshooting Procedures (Continued).**

---

**MALFUNCTION**

**TEST OR INSPECTION**

**CORRECTIVE ACTION**

---

Step 22. Remove control logic CCA in accordance with paragraph 5-3. Remove ETISD CCA in accordance with paragraph 5-4. Using multimeter, check for continuity from:

- XA1 pin 64 to XA2 pin 64
- XA2 pin 7 to J3 pin b
- XA1 pin 70 to J2 pin c

If continuity is not found, repair wiring as necessary, replace wiring harness in accordance with paragraph 5-10, replace connector XA1 in accordance with paragraph 5-16, replace connector XA2 in accordance with paragraph 5-20, replace connector J2 in accordance with paragraph 5-13, or replace connector J3 in accordance with paragraph 5-14 and repeat step 22.

If continuity is found proceed to step 23.

Step 23. Set RCS adapter UP LIMIT/OFF/DOWN LIMIT switch to UP LIMIT. Serial status display UP lamp should illuminate and TIU response monitor UP lamp should extinguish.

If Serial Status Display UP lamp illuminates and TIU response monitor UP lamp extinguishes, proceed to step 20.

If Serial Status Display UP lamp fails to illuminate and/or TIU response monitor UP lamp fails to extinguish, remove power. Replace control logic CCA in accordance with paragraph 5-3. Restore power and repeat step 23.

If Serial Status Display UP lamp still fails to illuminate and/or TIU response monitor UP lamp still fails to extinguish, remove power. Install original control logic CCA to UUT in accordance with paragraph 5-3. Replace ETISD CCA in accordance with paragraph 5-4 and repeat step 23.

If Serial Status Display UP lamp still fails to illuminate and/or TIU response monitor UP lamp still fails to extinguish, remove power. Proceed to step 24.

Step 24. Remove control logic CCA in accordance with paragraph 5-3. Remove ETISD CCA in accordance with paragraph 5-4. Using multimeter, check for continuity from:

- XA2 pin 52 to J3 pin G
- XA2 pin 43 to A1TB2-3
- XA1 pin 38 to A1TB2-3
- XA1 pin 70 to J2 pin c

If continuity is found, proceed to step 25.

Table 5-1. Direct Support Troubleshooting Procedures (Continued).

MALFUNCTION	TEST OR INSPECTION	CORRECTIVE ACTION
		<p>If continuity is not found, repair wiring as necessary, replace wiring harness in accordance with paragraph 5-10, replace connector XA1 in accordance with paragraph 5-16, replace connector XA2 in accordance with paragraph 5-20, replace connector J2 in accordance with paragraph 5-13, or replace connector J3 in accordance with paragraph 5-14 and repeat step 24.</p>
	Step 25. Set RCS adapter target controls UP/DOWN switch to DOWN. TIU response monitor DOWN lamp should illuminate.	<p>If DOWN lamp illuminates, proceed to step 27.</p> <p>If DOWN lamp does not illuminate, remove power. Replace control logic CCA in accordance with paragraph 5-3. Restore power and repeat step 25.</p> <p>If DOWN lamp still fails to illuminate, remove power. Install original control logic CCA to UUT in accordance with paragraph 5-3. Replace ETISD CCA in accordance with paragraph 5-4 and repeat step 25.</p> <p>If DOWN lamp still fails to illuminate, remove power. Proceed to step 26.</p>
	Step 26. Remove control logic CCA in accordance with paragraph 5-3. Remove ETISD CCA in accordance with paragraph 5-4. Using multimeter, check for continuity from:	<p>J2 pin c to XA1 pin 70  XA1 pin 63 to XA2 pin 63  XA2 pin 11 to J3 pin d</p> <p>If continuity is found, proceed to step 27.</p> <p>If continuity is not found, repair wiring as necessary, replace wiring harness in accordance with paragraph 5-10, replace connector XA1 in accordance with paragraph 5-16, replace connector XA2 in accordance with paragraph 5-20, replace connector J2 in accordance with paragraph 5-13, or replace connector J3 in accordance with paragraph 5-14 and repeat step 26.</p>

**Table 5-1. Direct Support Troubleshooting Procedures (Continued).**

---

<b>MALFUNCTION</b>	
<b>TEST OR INSPECTION</b>	
<b>CORRECTIVE ACTION</b>	

---

Step 27. Set RCS adapter UP LIMIT/OFF/DOWN LIMIT switch to DOWN LIMIT. Serial status display DWN lamp should illuminate and TIU response monitor DOWN lamp should extinguish.

If Serial Status Display DWN lamp illuminates and TIU response monitor DOWN lamp extinguishes, proceed to step 28.

If Serial Status Display DWN lamp fails to illuminate and/or TIU response monitor DOWN lamp fails to extinguish remove power. Replace control logic CCA in accordance with paragraph 5-3. Restore power and repeat step 27.

If Serial Status Display DWN lamp still fails to illuminate and/or TIU response monitor DOWN lamp still fails to extinguish, the problem is outside the TIU. Troubleshoot RCS adapter in accordance with TM 9-6920-742-14-1.

Step 28. Set RCS adapter AMTC main power ON/OFF switch to ON. TIU response MAIN POWER lamp should illuminate.

If MAIN POWER lamp illuminates, proceed to step 30.

If MAIN POWER lamp fails to illuminate, remove power. Replace control logic CCA in accordance with paragraph 5-3 and repeat step 28.

If MAIN POWER lamp still fails to illuminate, remove power. Install original control logic CCA in accordance with paragraph 5-3. Replace ETISD CCA in accordance with paragraph 5-4 and repeat step 28.

If MAIN POWER lamp still fails to illuminate, remove power and proceed to step 29.

Step 29. Remove control logic CCA in accordance with paragraph 5-3. Remove ETISD CCA in accordance with paragraph 5-4. Using multimeter, check for continuity from:

- XA1 pin 57 to XA2 pin 61
- XA2 pin 15 to J3 pin V

If continuity is found, proceed to step 30.

If continuity is not found, repair wiring as necessary, replace wiring harness in accordance with paragraph 5-10, replace connector XA1 in accordance with paragraph 5-16, replace connector XA2 in accordance with paragraph 5-20, or replace connector J3 in accordance with paragraph 5-14 and repeat step 29.



Table 5-1. Direct Support Troubleshooting Procedures (Continued).

MALFUNCTION	TEST OR INSPECTION	CORRECTIVE ACTION
Step 30. Set RCS adapter THERMAL TARGET ON/OFF switch to ON. TIU response monitor THERMAL lamp should illuminate.	If THERMAL lamp illuminates, proceed to step 32.	If THERMAL lamp fails to illuminate, remove power. Replace control logic CCA in accordance with paragraph 5-3 and repeat step 30.
	If THERMAL lamp still fails to illuminate, remove power. Install original control logic CCA in accordance with paragraph 5-3. Replace ETISD CCA in accordance with paragraph 5-4 and repeat step 30.	If THERMAL lamp still fails to illuminate, remove power and proceed to step 31.
Step 31. Remove control logic CCA in accordance with paragraph 5-3. Remove ETISD CCA in accordance with paragraph 5-4. Using multimeter, check for continuity from:	XA1 pin 17 to A1TB1-10 A1TB1-10 to J1 pin N XA2 pin 17 to A1TB1-10 XA2 pin 14 to A1TB2-2 A1TB2-2 to J3 pin f A1TB2-2 to J5 pin B A1TB2-6 to J5 pin D	If continuity is found, proceed to step 32.
	If continuity is not found, repair wiring as necessary, replace wiring harness in accordance with paragraph 5-10, replace connector XA1 in accordance with paragraph 5-16, replace connector XA2 in accordance with paragraph 5-20, replace connector J1 in accordance with paragraph 5-12, replace connector J3 in accordance with paragraph 5-14, or replace connector J5 in accordance with paragraph 5-15 and repeat step 31.	
Step 32. Connect multimeter between (RCS adapter) BATTERY CHARGER (+) red and (-) black. Multimeter should indicate $14 \pm 1.5$ vdc.	If multimeter indication is correct, UUT is operational. Remove power and disconnect test cables.	If multimeter indication is not correct, remove power and proceed to step 33.

Table 5-1. Direct Support Troubleshooting Procedures (Continued).

MALFUNCTION	TEST OR INSPECTION	CORRECTIVE ACTION
-------------	--------------------	-------------------

Step 33. Using multimeter, check for continuity from:

- J3 pin q to A1TB2-10
- A1TB2-10 to A2TB1-3
- A2TB1-2 to J3 pin r

If continuity is found, repeat step 32. If after repeating step 32, multimeter indication is still incorrect, remove RCS adapter connection from TIU connector J3 and place multimeter red lead on J3 pin q and black lead on J3 pin r. If multimeter indicates  $12 \pm 1.5$  vdc, the problem is outside the TIU. Troubleshoot RCS adapter in accordance with TM 9-6920-742-14-1.

If continuity is not found, repair wiring as necessary, replace wiring harness in accordance with paragraph 5-10, or replace connector J3 in accordance with paragraph 5-14 and repeat step 32.

**3. Simulator or target mechanism connected to ICB/High Power does not respond to RCS commands.**

**WARNING**



**High voltages are present inside the equipment. Death or injury from electric shock may result from failure to observe safety precautions**

Step 1. Place ICB/High Power, IMTC and ITM CB1s in the ON positions.

If ICB/High Power CB1 trips, disconnect P2 from J1 of the IMTC. Reset CB1. If CB1 now holds, fault is external to ICB/High Power. Refer to TM 9-6920-742-14-3. If CB1 still does not hold, proceed to step 2.

If all CB1s hold, test ITM and IMTC using local test switches. If ITM and IMTC operate with test switches, proceed to step 3. If ITM and IMTC fail to operate with test switches, proceed to step 2.

Step 2. Using multimeter, make the following voltage checks:

TB5-1	to	TB5-2	240 $\pm$ 24 vac	lane power
1st CB1 Load	to	2nd CB1 Load	240 $\pm$ 24 vac	CB1 output
T1-0 (primary)	to	T1-240 (primary)	240 $\pm$ 24 vac	T1 primary
TB3-6	to	TB3-7	28 $\pm$ 3 vac	T1 secondary
TB3-5	to	TB3-1	28 $\pm$ 3 vdc	rectifier output

Table 5-1. Direct Support Troubleshooting Procedures (Continued).

MALFUNCTION	TEST OR INSPECTION	CORRECTIVE ACTION
		<p>If 240 <math>\pm</math>24 vac is not present at lane power points, lane power cable is open. Refer to TM 9-6920-742-1.</p>
		<p>If 240 <math>\pm</math>24 vac is not present between load terminals of CB1 and is good at lane power points, replace CB1 in accordance with paragraph 4-14.</p>
		<p>If 240 <math>\pm</math>24 vac is still not present at T1 primary, tag and disconnect gas tube surge arrestor terminals from each EMI Filter. Check for continuity between terminals and from each terminal to ground. If continuity is present, replace the arrestor in accordance with paragraph 5-27.</p>
		<p>If 240 <math>\pm</math>24 vac is present between load terminals of CB1 but not at T1 primary, remove power. Tag and disconnect wires from both ends of the EMI filters (FL1 and FL2). Place multimeter probes on each filter terminal stud and observe for continuity. If no continuity, replace the filter. If continuity is observed, reverse the probes between two filter studs and observe multimeter for a momentary deflection. If no deflection is observed on either filter stud, replace the open filter in accordance with paragraph 5-26.</p>
		<p>If 240 <math>\pm</math>24 vac is present at T1 primary but 28 <math>\pm</math>3 vac is not present at T1 secondary, replace transformer assembly in accordance with paragraph 5-31.</p>
		<p>If all ac voltages are good and 28 <math>\pm</math>3 vdc is not present between TB3-5 and TB3-1, replace rectifier bracket assembly in accordance with paragraph 5-30.</p>
	Step 3.	<p>Remove screws and lockwashers from TB2 and lift leads of R1 through R8 from terminal board. Using multimeter, check resistors R1 through R8 for 100 <math>\pm</math>10 ohms.</p>
		<p>If multimeter indications are correct, proceed to step 4.</p>
		<p>If multimeter indications are not correct, replace resistor and retest.</p>
	Step 4.	<p>Tag and disconnect capacitor from TB2, terminal 5 and terminal 6. Using a multimeter, place one probe on the loose terminal, and the other probe on opposite end of capacitor. Observe for a discharge on the multimeter.</p>
		<p>If no discharge, reverse the multimeter probes and check again. If still no discharge, replace the capacitor in accordance with paragraph 5-29.</p>
		<p>If discharge is observed, the capacitor is serviceable, proceed to step 5.</p>

Table 5-1. Direct Support Troubleshooting Procedures (Continued).

MALFUNCTION	TEST OR INSPECTION	CORRECTIVE ACTION
-------------	--------------------	-------------------

Step 5. Test continuity of cable assembly W101-2 in accordance with Unit Troubleshooting malfunction 5.

If continuity is found, proceed to step 6.

If continuity is not found, replace cable in accordance with paragraph 4-17, or repair cable by replacing cable components in accordance with paragraph 5-38, 5-39, or 5-40 and repeat step 5.

Step 6. Test continuity of wiring harness in accordance with Unit Troubleshooting malfunction 5.

If continuity is found, replace suppression board in accordance with paragraph 5-28.

If continuity is not found replace wiring harness assembly in accordance with paragraph 4-15.

**4. Simulator or target mechanism connected to ICW/Low Power does not respond to RCS commands.**

**WARNING**



**High voltages are present inside the equipment. Death or injury from electric shock may result from failure to observe safety precautions.**

Step 1. Place ICB/Low Power and target mechanism CB1s in the ON positions.

If ICB/Low Power CB1 trips, disconnect P2 from J1 of the target mechanism. Reset CB1. If CB1 now holds, fault is external to ICB/Low Power. Refer to appropriate target mechanism technical manual. If CB1 still does not hold, proceed to step 2.

If all CB1s hold, test target mechanism using local test switch. If target mechanism operates with test switch, proceed to step 3. If target mechanism fails to operate with test switch, proceed to step 2.

**Table 5-1. Direct Support Troubleshooting Procedures (Continued).**

**MALFUNCTION**

**TEST OR INSPECTION**

**CORRECTIVE ACTION**

Step 2. Using multimeter, make the following voltage checks:

TB3-5	to	TB3-1	34 ±4 vdc	unloaded rectifier output
TB3-5	to	TB3-1	24 ±4 vdc	rectifier output
TB4-1	to	TB3-1	28 ±3 vac	T1 secondary
TB4-2	to	TB3-1	28 ±3 vac	T1 secondary
TB4-5	to	TB4-6	240 ±24 vac	T1 primary
TB5-1	to	TB5-2	240 ±24 vac	lane power input
1st CB1 Load	to	2nd CB1 Load	240 ±24 vac	CB1 output

If all ac voltages are good and 28 ±3 vdc is not present between TB3-5 and TB3-1, replace rectifier bracket assembly in accordance with paragraph 5-49.

If 240 ±24 vac is present at T1 primary but 28 ±3 vac is not present at T1 secondary, replace transformer assembly in accordance with paragraph 5-51.

If 240 ±24 vac is present between load terminals of CB1 but not at T1 primary, remove power. Tag and disconnect wires from both ends of the EMI filters (FL1 and FL2). Place multimeter probes on each filter terminal stud and observe for continuity. If no continuity, replace the filter. If continuity is observed, alternate the probes between one filter stud and ground and observe multimeter for a momentary deflection. Perform this test on each stud of each filter. If no deflection is observed on either filter stud, replace the open filter in accordance with paragraph 5-46.

If 240 ±24 vac is still not present at T1 primary, tag and disconnect gas tube surge arrester terminals from each EMI Filter. Check for continuity between terminals and from each terminal to ground. If continuity is present, replace the arrester in accordance with paragraph 5-47.

If 240 ±24 vac is not present between load terminals of CB1 and is good at lane power points, replace CB1 in accordance with paragraph 4-20.

If 240 ±24 vac is not present at lane power points, lane power cable is open. Refer to TM 9-6920-742-14-1.

Step 3. Remove screws and lockwashers from TB2 and lift leads of R1 through R8 from terminal. Using multimeter, check resistors R1 through R8 for 100 ±10 ohms.

If multimeter indications are correct, proceed to step 4.

If multimeter indications are not correct, replace resistor and retest.

**Table 5-1. Direct Support Troubleshooting Procedures (Continued).**

<b>MALFUNCTION</b>
<b>TEST OR INSPECTION</b>
<b>CORRECTIVE ACTION</b>
<p>Step 4. Tag and disconnect capacitor from TB2, terminal 5 and terminal 6. Using a multimeter, place one probe on the loose terminal, and the other probe on opposite end of capacitor. Observe for a discharge on the multimeter.</p> <p>If no discharge, reverse the multimeter probes and check again. If still no discharge, replace the capacitor in accordance with paragraph 5-48.</p> <p>If discharge is observed, the capacitor is serviceable, proceed to step 5.</p>
<p>Step 5. Test continuity of cable assembly W101-1 in accordance with Unit Troubleshooting malfunction 7.</p> <p>If continuity is found, proceed to step 6.</p> <p>If continuity is not found, replace cable in accordance with paragraph 4-23, or repair cable by replacing cable components in accordance with paragraph 5-58, 5-59, or 5-60, and repeat step 5.</p>
<p>Step 6. Test continuity of wiring harness in accordance with Unit Troubleshooting malfunction 5.</p> <p>If continuity is found, replace suppression board in accordance with paragraph 5-45.</p> <p>If continuity is not found replace wiring harness assembly in accordance with paragraph 4-15.</p>

## **SECTION II. DIRECT SUPPORT MAINTENANCE PROCEDURES**

### **5-2 GENERAL.**

This section contains the instructions for removal, repair, and installation of major components of the TIU, ICB/High Power, and ICB/Low Power. The instructions consist of the initial setup and step-by-step procedures to perform the task. Observe all warnings, cautions, and safety precautions during the performance of these tasks.

**5-3 TIU CONTROL LOGIC CCA REPLACEMENT (9341125).**

**INITIAL SETUP**

**Materials/Parts:**

Control logic CCA (9341125)  
Grease (item 2, appendix D)

**References:**

Paragraph 2-4b  
TM 9-6920-742-14-1

**a. Removal.**

- (1) Set CB1 of ICB/Low Power to the OFF position.
- (2) Set TIU CB1 (1) to the OFF position.

**WARNING**



When working inside the equipment after power has been turned off, always ground every part before touching it. Failure to do so could result in serious injury or death.

- (3) Depress pressure relief valve (2) to equalize pressure before removing cover assembly.
- (4) Release latches and remove cover assembly (3).
- (5) Release control logic CCA keepers (4).

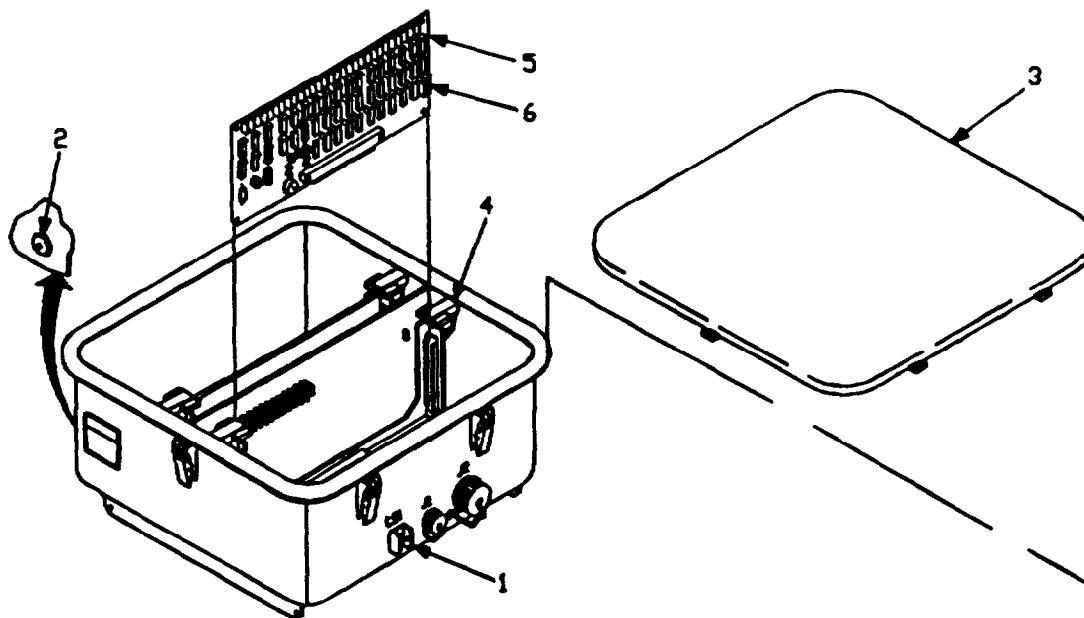

**5-3 TIU CONTROL LOGIC CCA REPLACEMENT (9353793) (CONTINUED).**

- (6) Unplug control logic CCA (5) from connector.
- (7) Record dual-in-line/address switch (6) position.

**b. Installation.**

- (1) Set dual-in-line/address switch position in accordance with recorded address. If address was not recorded, determine switch position in accordance with paragraph b.
- (2) Plug control logic CCA (5) into connector.
- (3) Secure control logic CCA keepers (4).
- (4) Apply a uniform, thin coating of grease to entire gasket surface.
- (5) Install cover assembly (3) and fasten latches.
- (6) Set CB1 of ICB/Low Power to the ON position.
- (7) Set TIU CB1 (1) to the ON position.
- (8) Test in accordance with TM 9-6920-742-14-1.

**5-4 TIU ETISD CCA REPLACEMENT (9387536).**

**INITIAL SETUP**

**Materials/Parts:**

ETISD CCA (9387536)  
Grease (item 2, appendix D)

**References:**

TM 9-6920-742-14-1

---

**a. Removal.**

- (1) Set CB1 of ICB/Low Power to the OFF position.
- (2) Set TIU CB1 (1) to the OFF position.

**WARNING**



**When working inside the equipment after power has been turned off, always ground every part before touching it. Failure to do so could result in serious injury or death.**

- (3) Depress pressure relief valve (2) to equalize pressure before removing cover assembly.



- (4) Release latches and remove cover assembly (3).
- (5) Release ETISD CCA keepers (4).
- (6) Unplug ETISD CCA (5) from connector.

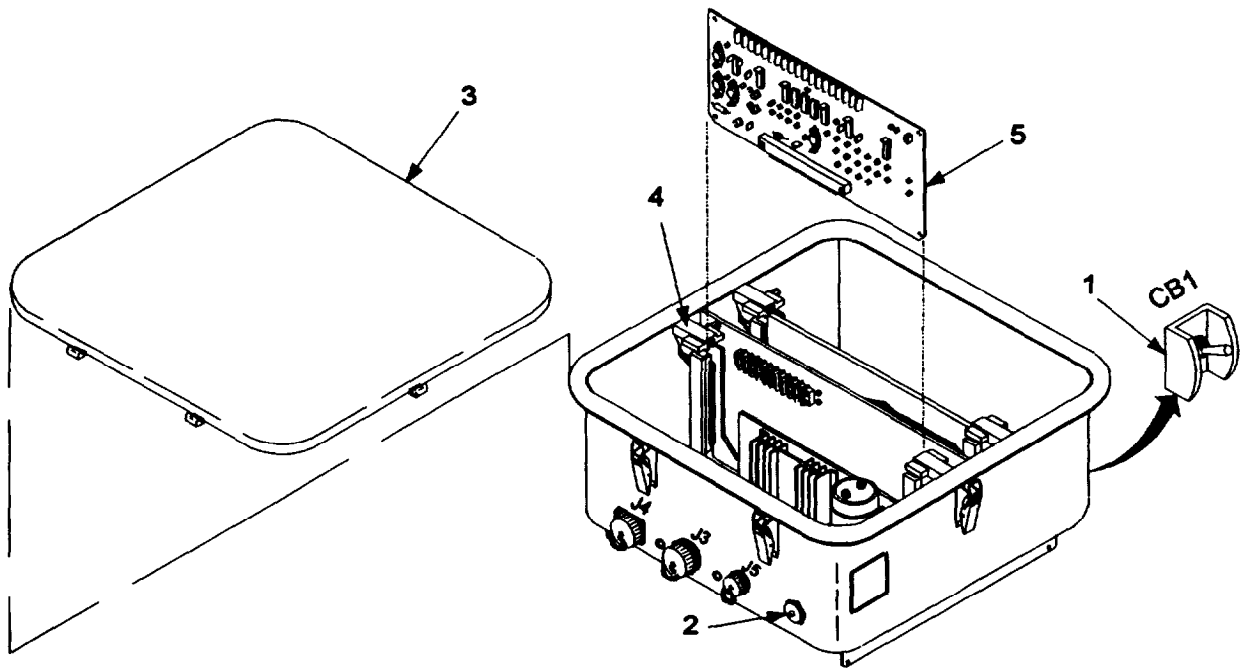

**b. Installation.**

- (1) Plug ETISD CCA into connector.
- (2) Secure ETISD CCA keepers (4).
- (3) Apply a uniform, thin coating of grease to entire gasket surface.
- (4) Install cover assembly (3) and fasten latches.
- (5) Set CB1 of ICB/Low Power to the ON position.
- (6) Set TIU CB1 (1) to the ON position.
- (7) Test in accordance with TM 9-6920-742-14-1.

**5-5 TIU HOUSING REPLACEMENT (9353783).**

**INITIAL SETUP**

**Tools and Special Tools:**

- General mechanic's automotive tool kit
- Torque wrench

**Materials/Parts:**

- TIU housing (9353783)
- Gasket (9387225)
- Self-locking nut (NAS679CO4M)
- Self-locking nut (MS21083C4)

**Materials/Parts (Continued):**

- Self-locking nut (NAS679C06M)
- Adhesive (item 1, appendix D)
- Grease (item 2, appendix D)
- Adhesive (item 10, appendix D)
- Sealing compound (item 9, appendix D)

**References:**

- TM 9-6920-742-14-1

**a. Removal.**

- (1) Set CB1 of ICB/Low Power to the OFF position.
- (2) Set TIU CB1 (1) to the OFF position.

**WARNING**

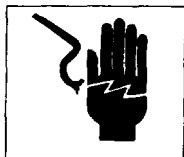

**When working inside the equipment after power has been turned off, always ground every part before touching it. Failure to do so could result in serious injury or death.**

- (3) Depress pressure relief valve (2) to equalize pressure before removing cover assembly.
- (4) Release latches and remove cover assembly (3).
- (5) Release control logic CCA keepers (4).
- (6) Unplug control logic CCA (5) from connector.
- (7) Release ETISD CCA keepers (6).
- (8) Unplug ETISD CCA (7) from connector.
- (9) Tag leads from TB1 (8) and TB2 (9) on center plate assembly.
- (10) Remove screws (10) and lockwashers (11) and remove leads from TB1 and TB2.
- (11) Remove four screws (12), washers (13), and self-locking nuts (14) securing card holder assembly (15) to housing.
- (12) Remove four screws (16) and nuts (17) securing connectors XA1 (18) and XA2 (19) to card holder assembly.

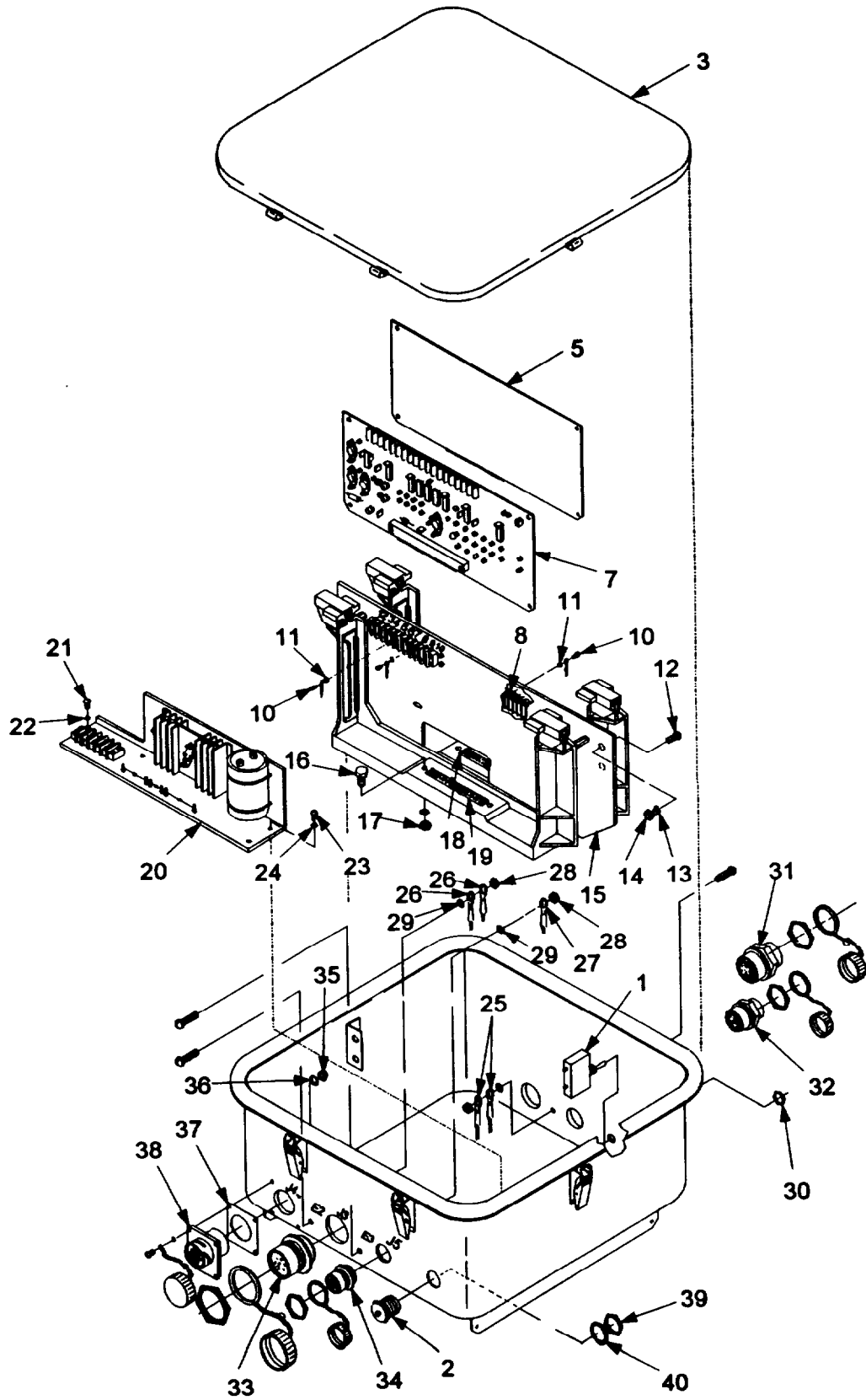

**5-5 TIU HOUSING REPLACEMENT (9353793) (CONTINUED).**

- (13) Tag leads on TB1 of the power supply (20).
- (14) Remove screws (21) and lockwashers (22) and remove leads from TB1.
- (15) Remove four screws (23) and flatwashers (24) and remove the power supply.
- (16) Tag leads from chassis grounds E1 (25), E2 (26), and E3 (27).
- (17) Remove self-locking nuts (28) and flatwashers (29) and remove leads from chassis grounds.
- (18) Remove mounting nut (30) from CB1 and remove circuit breaker.
- (19) Remove mounting nuts and link chain attachment from J1 (31), J2 (32), J3 (33), and J5 (34).
- (20) Remove connectors from housing.
- (21) Remove silicone rubber from connector J4 mounting screws.
- (22) Remove four self-locking nuts (35), washers (36), and packing retainer (37) and remove connector J4 (38).
- (23) Remove mounting nut (39), gasket (40), and remove pressure relief valve from housing.

**b. Installation.**

- (1) Apply adhesive to TIU housing gasket surface area.
- (2) Position gasket on housing.
- (3) Apply sealing compound to threads and install pressure relief valve (2) in housing. Install gasket (40) on pressure relief valve.
- (4) Torque mounting nut (39) to 70-75 pound-inches (7.96-8.53 newton-meters).
- (5) Apply sealing compound to threads and insert connector J4 (38) into housing.
- (6) Install packing retainer (37), four screws, washers (36), and new self-locking nuts (35). Torque to 7-9 pound-inches (.80-1.02 newton-meters)
- (7) Apply silicone rubber to J4 mounting screws and self-locking nuts.
- (8) Apply grease to O-ring groove of connectors J1 (31), J2 (32), J3 (33), and J5 (34).
- (9) Apply sealing compound to threads and position J1, J2, J3, and J5 into housing in marked positions.
- (10) Install chain link attachments and mounting nuts on each connector and torque as follows:

J1	70-75 pound-inches	7.96-8.53 newton-meters
J2	90-95 pound-inches	10.24-10.81 newton-meters
J3	100-110 pound-inches	11.38-12.51 newton-meters
J5	55-60 pound-inches	6.26-6.83 newton-meters

- (11) Apply sealing compound to threads and position circuit breaker into housing.
- (12) Install mounting nut (30) and torque to 20-26 pound-inches (2.28-2.96 newton-meters).
- (13) Connect chassis grounds to E1 (25), E2 (26), and E3 (27).
- (14) Secure chassis grounds with flatwashers (29) and new self-locking nuts (28).
- (15) Install power supply (20) to housing and secure with four screws (23) and flatwashers (24).
- (16) Connect leads to TB1 on power supply and secure with screws (21) and lockwashers (22).
- (17) Install XA1 (18) and XA2 (19) into card holder assembly and secure with four screws (16) and nuts (17).
- (18) Position card holder assembly (15) into housing and secure with four screws (12), washers (13), and new self-locking nuts (14).
- (19) Connect leads to TB1 (8) and TB2 (9) on center plate assembly and secure with screws (10) and lockwashers (11).
- (20) Plug ETISD CCA (7) into connector.
- (21) Fasten ETISD CCA keepers (6).
- (22) Plug control logic CCA (5) into connector.
- (23) Fasten control logic CCA keepers (4).
- (24) Apply a uniform, thin coating of grease to entire gasket surface.
- (25) Install cover assembly (3) and fasten latches.
- (26) Set CB1 of ICB/Low Power to the ON position.
- (27) Set TIU CB1 (1) to the ON position.
- (28) Test in accordance with TM 9-6920-742-14-1.

## 5-6 TIU CARD HOLDER ASSEMBLY REPLACEMENT (9353816).

### INITIAL SETUP

#### Tools and Special Tools:

General mechanic's automotive tool kit

#### Materials/Parts:

Card holder assembly (9353816)

Self-locking nut (NAS679C06M)

Grease (item 2, appendix D)

#### References:

TM 9-6920-742-14-1

---

#### a. Removal.

- (1) Set CB1 of ICB/Low Power to the OFF position.
- (2) Set TIU CB1 (1) to the OFF position.

### WARNING

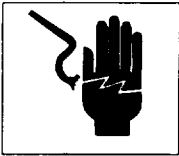

When working inside the equipment after power has been turned off, always ground every part before touching it. Failure to do so could result in serious injury or death.

- (3) Depress pressure relief valve (2) to equalize pressure before removing cover assembly.
- (4) Release latches and remove cover assembly (3).
- (5) Release control logic CCA keepers (4).
- (6) Unplug control logic CCA (5) from connector.
- (7) Release ETISD CCA keepers (6).
- (8) Unplug ETISD CCA (7) from connector.
- (9) Tag and disconnect all leads from TB1 (8) and TB2 (9).
- (10) Remove screws (10) and lockwashers (11) from TB1 and TB2 terminals.
- (11) Remove four screws (12), self-locking nuts (13), and flatwashers (14) securing card holder assembly (15) to housing.
- (12) Remove four screws (16) and nuts (17) securing connectors XA1 (18) and XA2 (19) to card holder assembly.
- (13) Remove card holder assembly from housing.

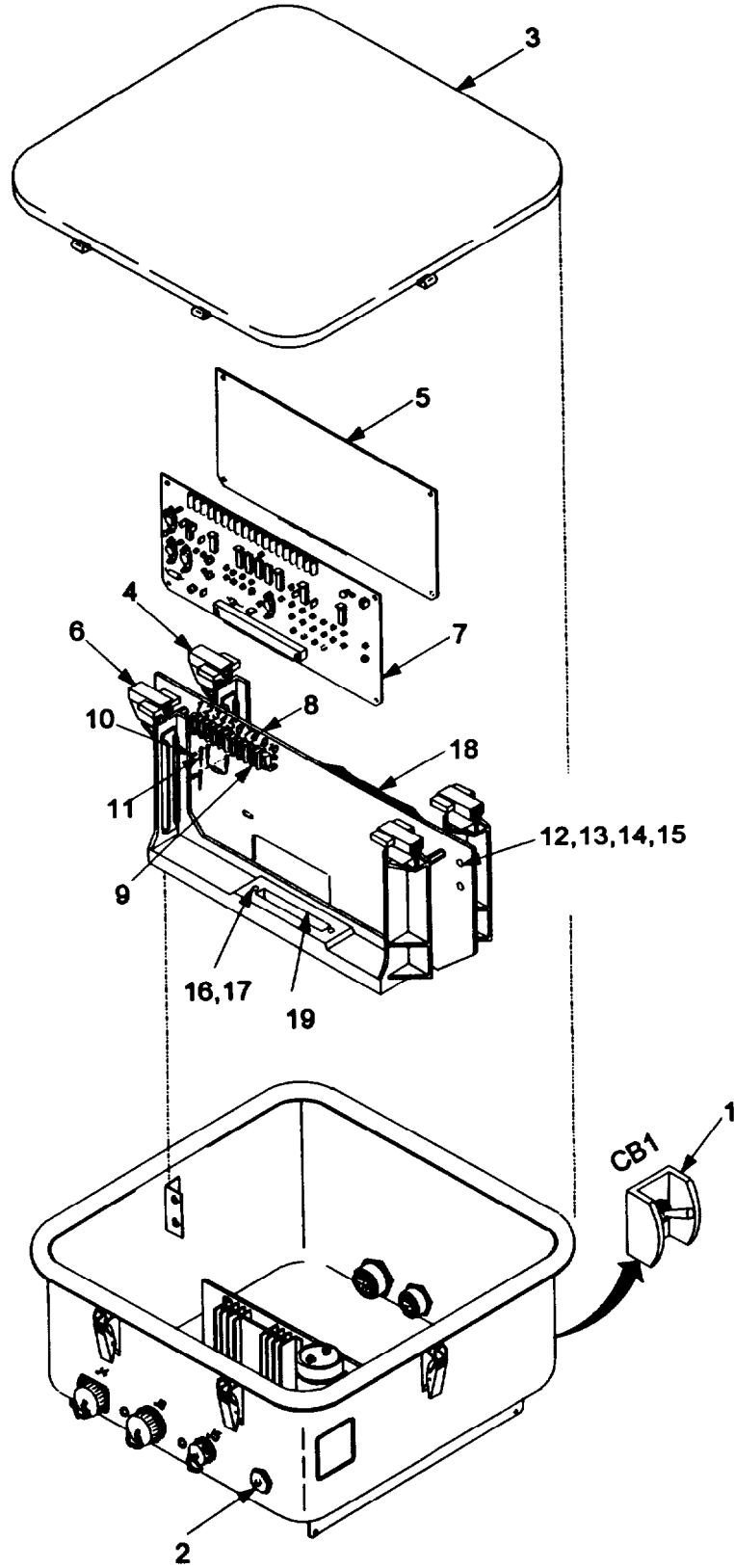

**5-6 TIU CARD HOLDER ASSEMBLY REPLACEMENT (9353793) (CONTINUED).**

**b. Installation.**

- (1) Install connectors XA1 (18) and XA2 (19) in card holder assembly (15) and secure with four screws (16) and nuts (17).
- (2) Position card holder assembly in housing.
- (3) Secure card holder assembly (15) to housing with four screws (12), self-locking nuts (13), and flatwashers (14).
- (4) Install all leads to TB1 (8) and TB2 (9).
- (5) Secure leads with screws (10) and lockwashers (11).
- (6) Plug ETISD CCA (7) into connector XA2.
- (7) Fasten ETISD CCA keepers (6).
- (8) Plug control logic CCA (5) into connector XA1.
- (9) Fasten control logic CCA keepers (4).
- (10) Apply a uniform, thin coating of grease to entire gasket surface.
- (11) Install cover assembly (3) and fasten latches.
- (12) Set CB1 of ICB/Low Power to the ON position.
- (13) Set TIU CB1 (1) to the ON position.
- (14) Test in accordance with TM 9-6920-742-14-1.



**5-7 CARD GUIDE FRAME REPLACEMENT (11829319).****INITIAL SETUP****Tools and Special Tools:**

General mechanic's automotive tool kit

**Equipment Condition:**

TIU card holder assembly removed  
(Reference paragraph 5-6)

**Materials/parts:**

Card guide frame (11829319)  
Self-locking nut (MS21083CO6)  
Grease (item 2, appendix D)  
Sealing compound (item 7, appendix D)

**References:**

TM 9-6920-742-14-1

**a. Removal.**

- (1) Remove four screws (1), self-locking nuts (2), flatwashers (3), and standoffs (4) from card guide frames (5).
- (2) Remove card guide frames from center plate.

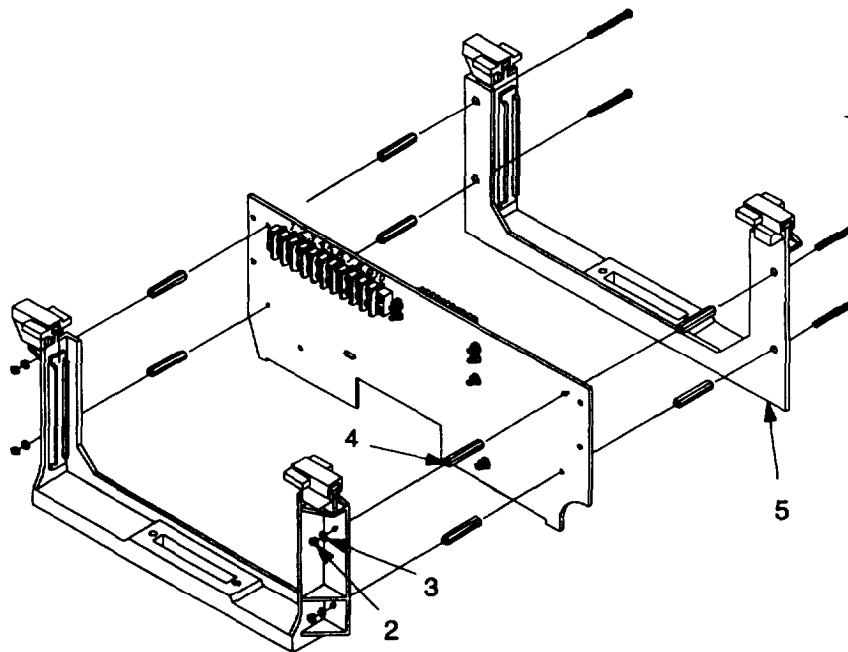
**b. Installation.**

- (1) Install card guide frames (5) to center plate.
- (2) Apply sealing compound to screws (1) and secure card guide frames with four screws, self-locking nuts (2), flatwashers (3), and standoffs (4).
- (3) Install card holder assembly. Refer to paragraph 5-6.
- (4) Test in accordance with TM 9-6920-742-14-1.

**5-8 SUPPRESSOR ASSEMBLY REPLACEMENT (9354186-3).**

**INITIAL SETUP**

**Tools and Special Tools:**

General mechanic's automotive tool kit

**Materials/Parts:**

Suppressor assembly (9354186-3)  
Grease (item 2, appendix D)

**References:**

TM 9-6920-742-14-1

---

**a. Removal.**

- (1) Set CB1 of ICB/Low Power to the OFF position.
- (2) Set TIU CB1 (1) to the OFF position.

**WARNING**



**When working inside the equipment after power has been turned off, always ground every part before touching it. Failure to do so could result in serious injury or death.**

- (3) Depress pressure relief valve (2) to equalize pressure before removing cover assembly.
- (4) Release latches and remove cover assembly (3).
- (5) Release control logic CCA keepers (4).
- (6) Unplug control logic CCA (5) from connector XA1.

**NOTE**

**Observe and record the polarity of the suppressor assembly. Band end goes to terminal 3.**

- (7) Remove screws (6), lockwashers (7), and terminal leads from TB1-3 (8) and TB1-7 (9).
- (8) Remove suppressor assembly (10) from TB1 on center plate.

**b. Installation.**

**NOTE**

**Polarity of suppressor assembly must be observed. Band end goes to terminal 3.**

- (1) Install suppressor assembly (10) to TB1-3 (8) and TB1 -7 (9).
- (2) Install removed leads, screws (6), and lockwashers (7) to TB1.
- (3) Plug control logic CCA (5) into connector XA1.

- (4) Fasten control logic CCA keepers (4).
- (5) Apply a uniform, thin coating of grease to entire gasket surface.
- (6) Install cover assembly (3) and fasten latches.
- (7) Set CB1 of ICB/Low Power to the ON position.
- (8) Set TIU CB1 (1) to the ON position.
- (9) Test in accordance with TM 9-6920-742-14-1.

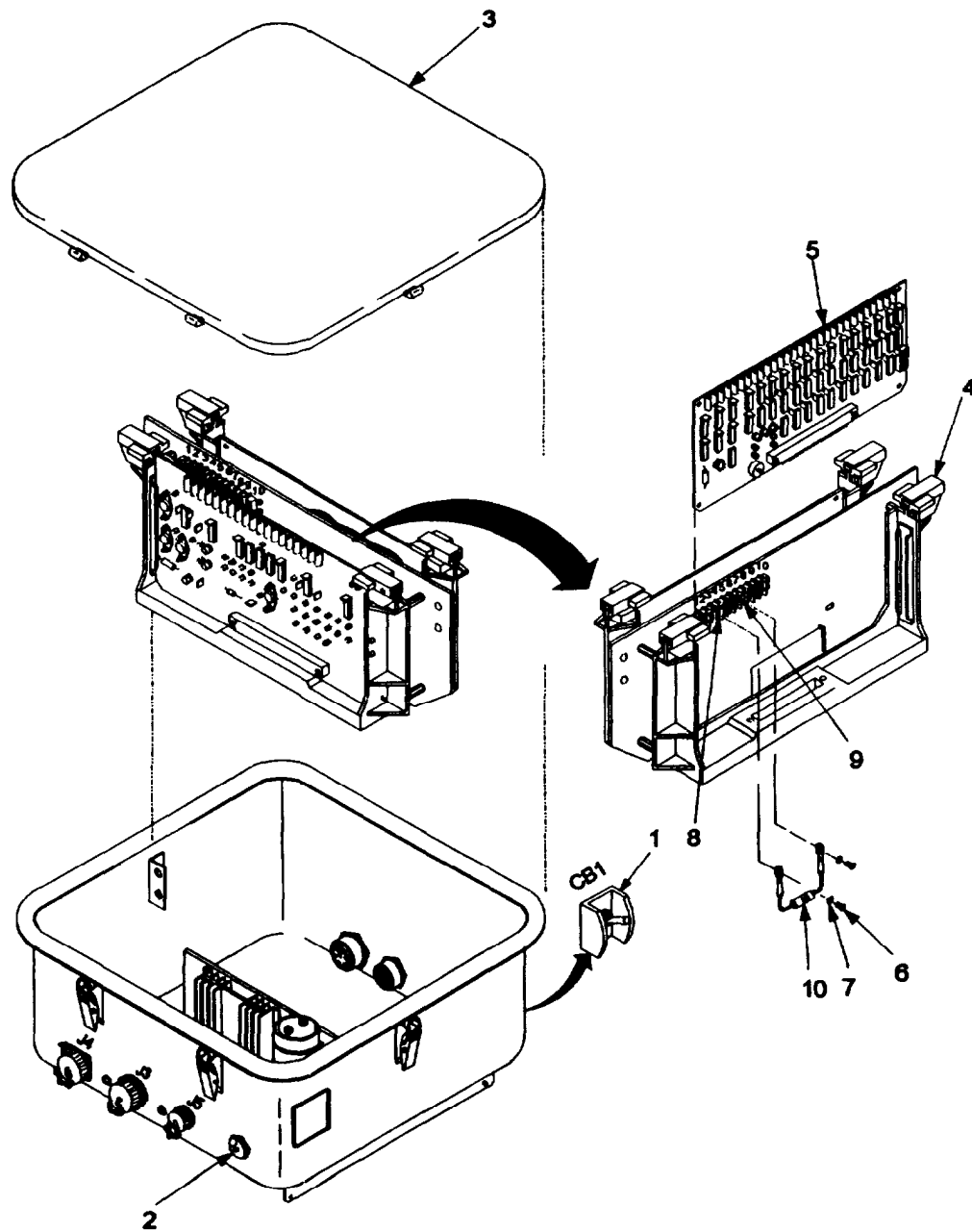

**5-9 ASSEMBLY OF TIU SUPPRESSOR ASSEMBLY (9354186-3).**

**INITIAL SETUP**

**Tools and Special Tools:**

General mechanic's automotive tool kit  
Soldering and desoldering set  
Crimping tool  
Wire strippers  
Heat gun

**Materials/Parts:**

Identification marker (9341182-32)  
Insulation sleeving  
(M22129-18AWGNATURAL)  
Insulation sleeving (M23053/5-207-C)  
Semiconductor device (JAN1N5650A)  
Terminal lug (MS77074-2)  
Solder (item 11, appendix D)

---

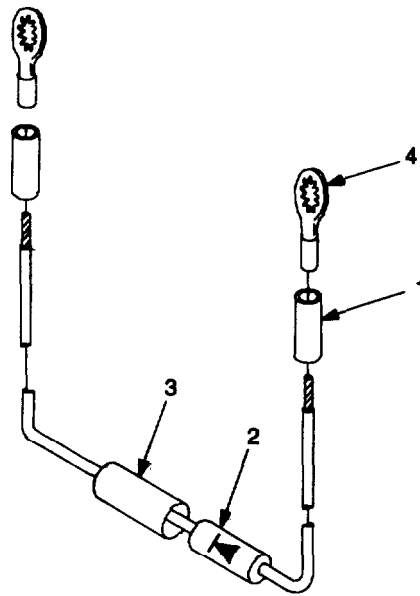

- a. Install insulation sleeving (1) (M22129-18AWGNATURAL) over both ends of semiconductor device (2).
- b. Apply heat and shrink tight.
- c. Install insulation sleeving (3) (M23053/5-207-C) over center of semiconductor device.
- d. Apply heat and shrink tight.
- e. Install identification marker over input end of semiconductor device.
- f. Apply heat and shrink tight.
- g. Strip insulation from both ends of semiconductor device back 1/4 inch (.635 cm).
- h. Install terminal lugs (4) to both ends of semiconductor device ensuring a distance of at least 2.30 inches (5.84 cm) between the centers.
- i. Crimp tight.
- j. Solder terminal lugs to semiconductor device.

**5-10 WIRING HARNESS REPLACEMENT (9353793).****INITIAL SETUP****Tools and Special Tools:**

General mechanic's automotive tool kit  
Torque wrench

**References:**

TM 9-6920-742-14-1

**Materials/Parts:**

Wiring harness (9353793)  
Self-locking nut (MS21083C4)  
Self-locking nut (NAS679CO6M)  
Grease (item 2, appendix D)  
Sealing compound (item 9, appendix D)

**a. Removal.**

- (1) Set CB1 of ICB/Low Power to the OFF position.
- (2) Set TIU CB1 (1) to the OFF position.

**WARNING**

When working inside the equipment after power has been turned off, always ground every part before touching it. Failure to do so could result in serious injury or death.

- (3) Depress pressure relief valve (2) to equalize pressure before removing cover assembly.
- (4) Release latches and remove cover assembly (3).
- (5) Release control logic CCA keepers (4).
- (6) Unplug control logic CCA (5) from connector.
- (7) Release ETISD CCA keepers (6).
- (8) Unplug ETISD CCA (7) from connector.
- (9) Remove screws (8) and lockwashers (9) from TB1 and TB2 terminals.
- (10) Tag and disconnect all leads from TB1 and TB2.
- (11) Remove four screws (10), self-locking nuts (11), and flatwashers (12), securing card holder assembly to housing (13).
- (12) Remove four screws (14) and nuts (15) securing connectors XA1 (16) and XA2 (17) to card holder assembly.
- (13) Remove card holder assembly from housing.
- (14) Tag all leads from TB1 (18) on power supply (19).

5-10 TIU WIRING HARNESS REPLACEMENT (9353793) (CONTINUED).

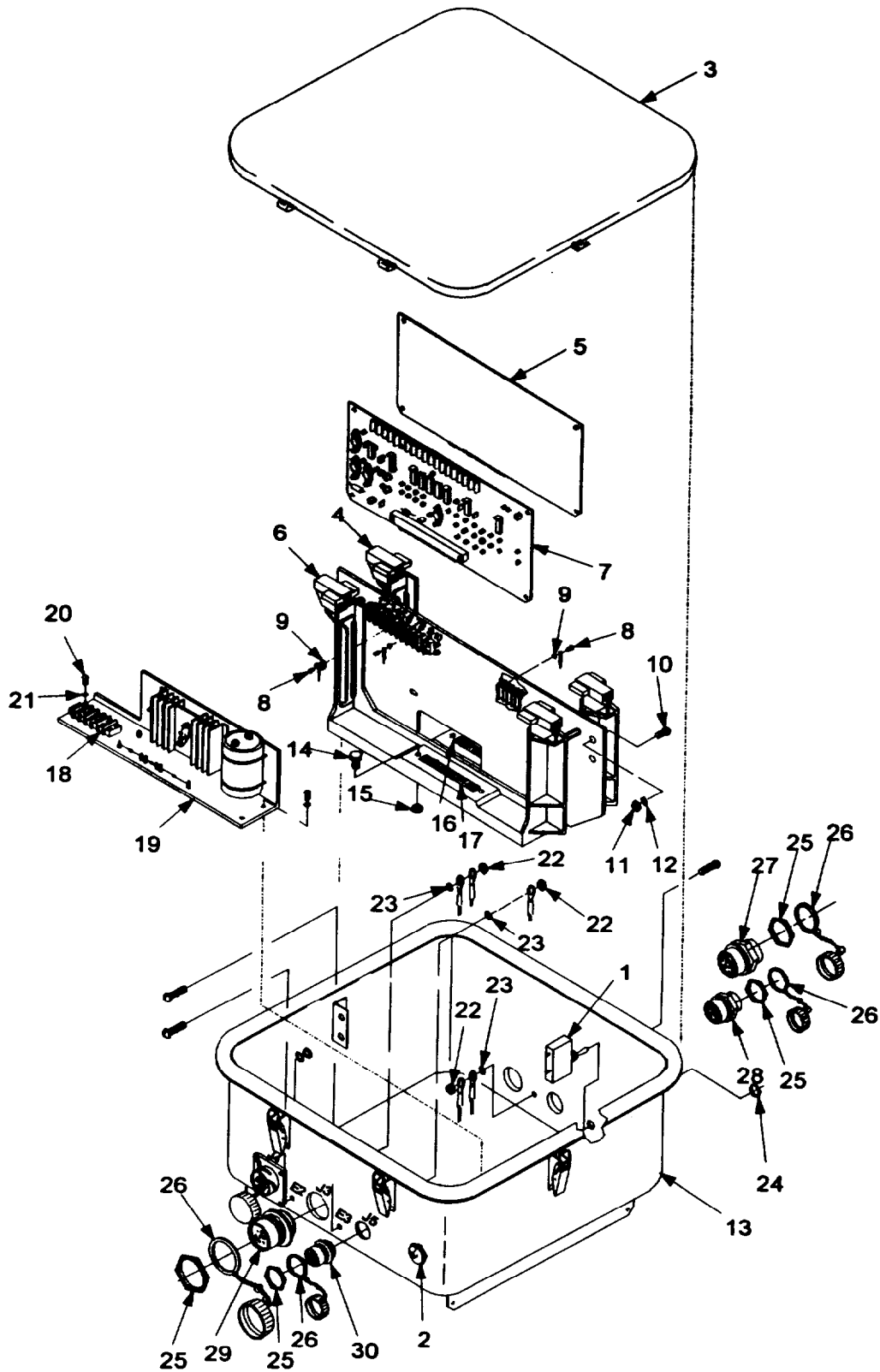

- (15) Remove screws (20) and lockwashers (21) from TB1 on power supply.
- (16) Tag all chassis grounds.
- (17) Remove self-locking nuts (22) and flatwashers (23) from chassis grounds E1, E2, and E3.
- (18) Remove mounting nut (24) and remove CB1 from housing.
- (19) Remove mounting nuts (25) and link chain attachments (26) from J1 (27), J2 (28), J3 (29), and J5 (30).
- (20) Remove connectors from housing.
- (21) Remove wiring harness.

**b. Installation.**

- (1) Apply grease to O-ring groove of connectors J1 (27), J2 (28), J3 (29), and J5 (30).
- (2) Apply sealing compound to threads and position J1, J2, J3, and J5 into housing (13) in marked positions.
- (3) Install chain link attachments (26) and mounting nuts (25) on each connector and torque as follows:

J1	70-75 pound-inches	7.96-8.53 newton-meters
J2	90-95 pound-inches	10.24-10.81 newton-meters
J3	100-110 pound-inches	11.38-12.51 newton-meters
J5	55-60 pound-inches	6.26-6.83 newton-meters

- (4) Apply sealing compound to threads, position circuit breaker (1) into housing, install mounting nut (24) and torque to 20-26 pound-inches (2.28-2.96 newton-meters).
- (5) Install chassis grounds to E1, E2, and E3.
- (6) Secure with new self-locking nuts (22) and flatwashers (23).
- (7) Install all leads to TB1 (18) on power supply (19).
- (8) Secure with screws (20) and lockwashers (21).
- (9) Install connectors XA1 (16) and XA2 (17) in card holder assembly.
- (10) Secure with four screws (14) and nuts (15).
- (11) Install card holder assembly in housing.
- (12) Secure with four screws (10), self-locking nuts (11), and flatwashers (12).

**5-10 TIU WIRING HARNESS REPLACEMENT (9353793) (CONTINUED).**

- (13) Install all leads to TB1 and TB2.
- (14) Secure with screws (8) and lockwashers (9).
- (15) Plug ETISD CCA (7) into connector XA2.
- (16) Fasten ETISD CCA keepers (6).
- (17) Plug control logic CCA (5) into connector XA1.
- (18) Fasten control logic CCA keepers (4).
- (19) Apply a uniform, thin coating of grease to entire gasket surface.
- (20) Install cover assembly (3) and fasten latches.
- (21) Set CB1 of ICB/Low Power to the ON position.
- (22) Set TIU CB1 (1) to the ON position.
- (23) Test in accordance with TM 9-6920-742-14-1.

**5-11 TIU CIRCUIT BREAKER REPLACEMENT (M39019/01-321).**

**INITIAL SETUP**

**Tools and Special Tools:**

- General mechanic's automotive tool kit
- Soldering and desoldering set
- Wire strippers
- Heat gun
- Torque wrench

**Materials/Parts:**

- Circuit breaker (M39019/01-321)
- Insulation sleeving (M23053/5-107-0)
- Sealing compound (item 9, appendix D)
- Solder (item 11, appendix D)

**References:**

- TM 9-6920-742-14-1

**a. Removal.**

- (1) Set CB1 of ICB/Low Power to the OFF position.
- (2) Set TIU CB1 (1) to the OFF position.

**WARNING**



When working inside the equipment after power has been turned off, always ground every part before touching it. Failure to do so could result in serious injury or death.



- (3) Depress pressure relief valve (2) to equalize pressure before removing cover assembly.
- (4) Release latches and remove cover assembly (3).
- (5) Remove insulation sleeving (4).
- (6) Tag and desolder leads (5) from CB1.
- (7) Remove CB1 mounting nut (6) and remove CB1 from housing.

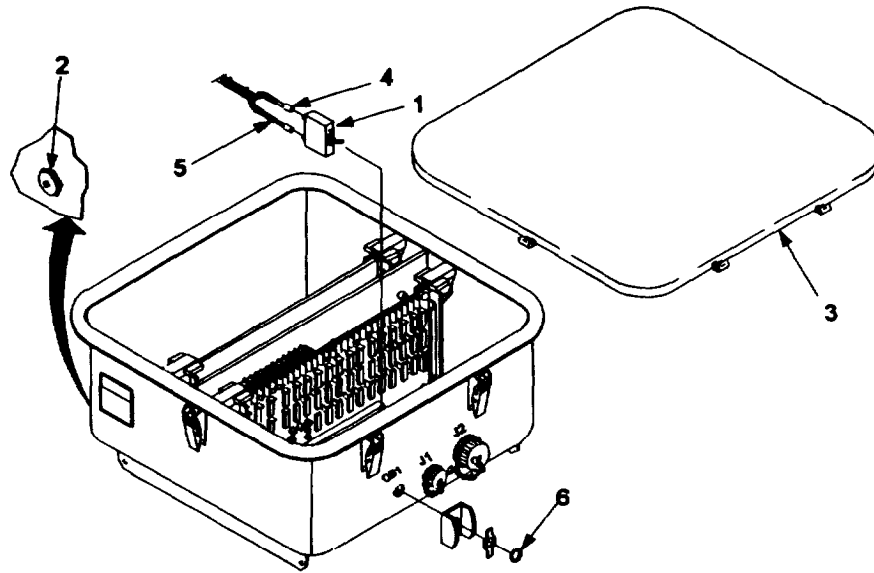

**b. Installation.**

- (1) Apply sealing compound to threads and install CB1 into housing and torque mounting nut (6) to 20-26 pound-inches (2.28-2.96 newton-meters).
- (2) Cut off wiring harness leads (5) even with insulation
- (3) Strip wiring harness leads back 3/16-inch (.477 cm).
- (4) Place insulation sleeving (4) over ends of wiring harness leads.
- (5) Solder wiring harness leads to terminals.
- (6) Slide insulation sleeving over terminals and apply heat to shrink tight.
- (7) Apply a uniform, thin coating of grease to entire gasket surface.
- (8) Install cover assembly (3) and fasten latches.
- (9) Set CB1 of ICB/Low Power to the ON position.
- (10) Set TIU CB1 (1) to the ON position.
- (11) Test in accordance with TM 9-6920-742-14-1.

## 5-12 TIU CONNECTOR J1 REPLACEMENT (MS3124E16-14P).

### INITIAL SETUP

#### Tools and Special Tools:

General mechanic's automotive tool kit  
Wire strippers  
Crimping tool  
Torque wrench

#### Materials/Parts:

Connector (MS3124E16-14P)  
Grease (item 2, appendix D)  
Sealing compound (item 9, appendix D)

#### References:

TM 9-6920-742-1 4-1

---

- a. Set CB1 of ICB/Low Power to the OFF position.
- b. Set TIU CB1 (1) to the OFF position.

### WARNING

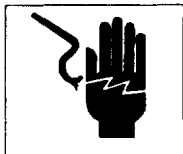

When working inside the equipment after power has been turned off, always ground every part before touching it. Failure to do so could result in serious injury or death.

- c. Depress pressure relief valve (2) to equalize pressure before removing cover assembly.
- d. Release latches and remove cover assembly (3).
- e. Remove connector mounting nut (4) and link chain assembly (5).
- f. Remove connector from housing (6).
- g. Tag all connector leads (7) and remove leads and crimped pins (8) from rear of connector.
- h. Cut leads as close to crimped pins as possible.
- i. Strip leads back 3/16-inch (.477 cm).
- j. Crimp new pins onto stripped leads.
- k. Insert pins in rear of connector.
- l. Install connector sealing plugs in rear of connector.
- m. Apply sealing compound to threads, apply grease to O-ring groove (9) and install connector in housing.
- n. Install link chain assembly and torque connector mounting nut to 70-75 pound-inches (7.96-8.53 newton-meters).

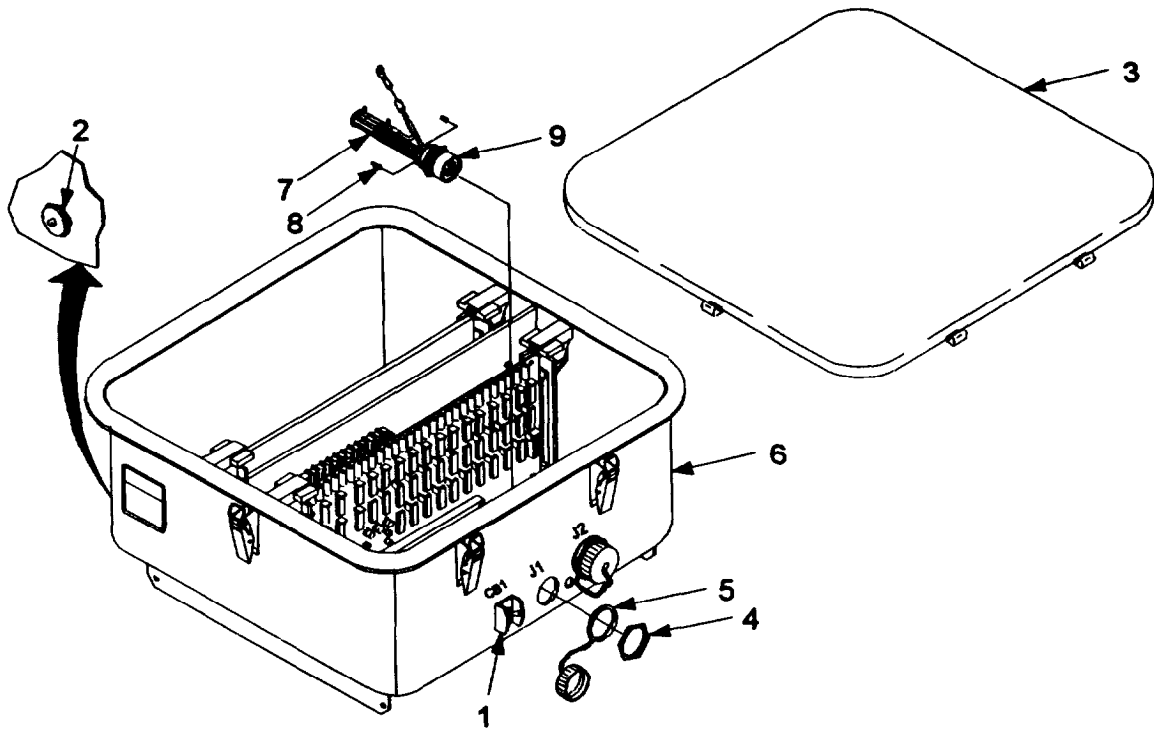

- o. Apply a uniform, thin coating of grease to entire gasket surface.
- p. Install cover assembly and fasten latches.
- q. Set CB1 of ICB/Low Power to the ON position.
- r. Set TIU CB1 to the ON position.
- s. Test in accordance with TM 9-6920-742-14-1.

**5-13 TIU CONNECTOR J2 REPLACEMENT (MS3474W20-39S).**

**INITIAL SETUP**

**Tools and Special Tools:**

- General mechanic's automotive tool kit
- Wire strippers
- Crimping tool
- Torque wrench

**Materials/Parts:**

- Connector (MS3474W20-39S)
- Grease (item 2, appendix D)
- Sealing compound (item 9, appendix D)

**References:**

- TM 9-6920-742-14-1

- a. Set CB1 of ICB/Low Power to the OFF position.
- b. Set TIU CB1 (1) to the OFF position.

**WARNING**

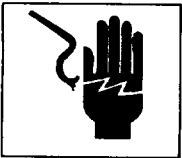

When working inside the equipment after power has been turned off, always ground every part before touching it. Failure to do so could result in serious injury or death.

- c. Depress pressure relief valve (2) to equalize pressure before removing cover assembly.

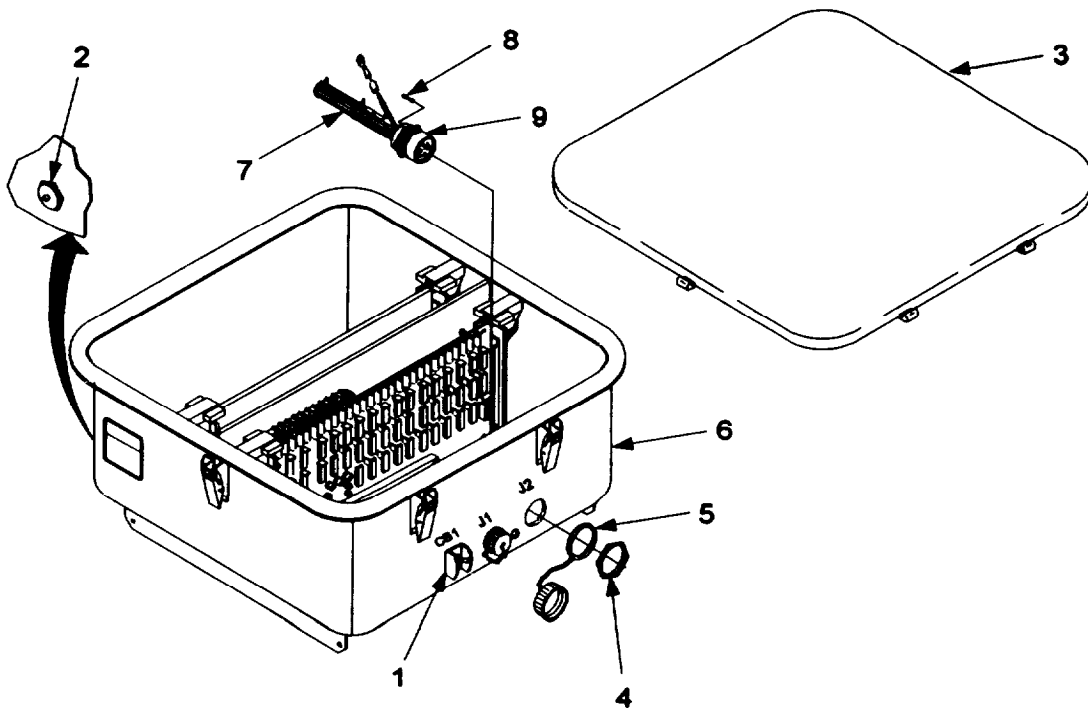

- d. Release latches and remove cover assembly (3).
- e. Remove connector mounting nut (4) and link chain assembly (5).
- f. Remove connector from housing (6).
- g. Tag all connector leads (7) and remove leads and crimped pins (8) from rear of connector.
- h. Cut leads as close to crimped pins as possible.
- i. Strip leads back 3/16-inch (.477 cm).
- j. Crimp new pins onto stripped leads.
- k. Insert pins in rear of connector.
- l. Install connector sealing plugs in rear of connector.
- m. Apply sealing compound to threads, apply grease to O-ring groove (9) and install connector in housing.
- n. Install link chain assembly and torque connector mounting nut to 90-95 pound-inches (10.24-10.81 newton-meters).
- o. Apply a uniform, thin coating of grease to entire gasket surface.
- p. Install cover assembly and fasten latches.
- q. Set CB1 of ICB/Low Power to the ON position
- r. Set TIU CB1 to the ON position.
- s. Test in accordance with TM 9-6920-742-14-1.

**5-14 TIU CONNECTOR J3 REPLACEMENT (MS3474W22-41S).**

**INITIAL SETUP**

**Tools and Special Tools:**

General mechanic's automotive tool kit  
Wire strippers  
Crimping tool  
Torque wrench

**Materials/Parts:**

Connector (MS3474W22-41S)  
Grease (item 2, appendix D)  
Sealing compound (item 9, appendix D)

**References:**

Power supply removal  
(reference paragraph 4-8)  
TM 9-6920-742-14-1

---

- a. Set CB1 of ICB/Low Power to the OFF position.
- b. Set TIU CB1 (1) to the OFF position.

**WARNING**

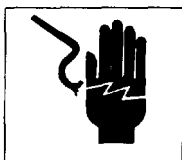

**When working inside the equipment after power has been turned off, always ground every part before touching it. Failure to do so could result in serious injury or death.**

- c. Depress pressure relief valve (2) to equalize pressure before removing cover assembly.
- d. Release latches and remove cover assembly (3).
- e. Remove power supply. Refer to paragraph 4-8.
- f. Remove connector mounting nut (4) and link chain assembly (5).
- g. Remove connector from housing (6).
- h. Tag all connector leads (7) and remove leads and crimped pins (8) from rear of connector.
- i. Cut leads as close to crimped pins as possible.
- j. Strip leads back 3/16-inch (.477 cm).
- k. Crimp new pins onto stripped leads.
- l. Insert pins in rear of connector.

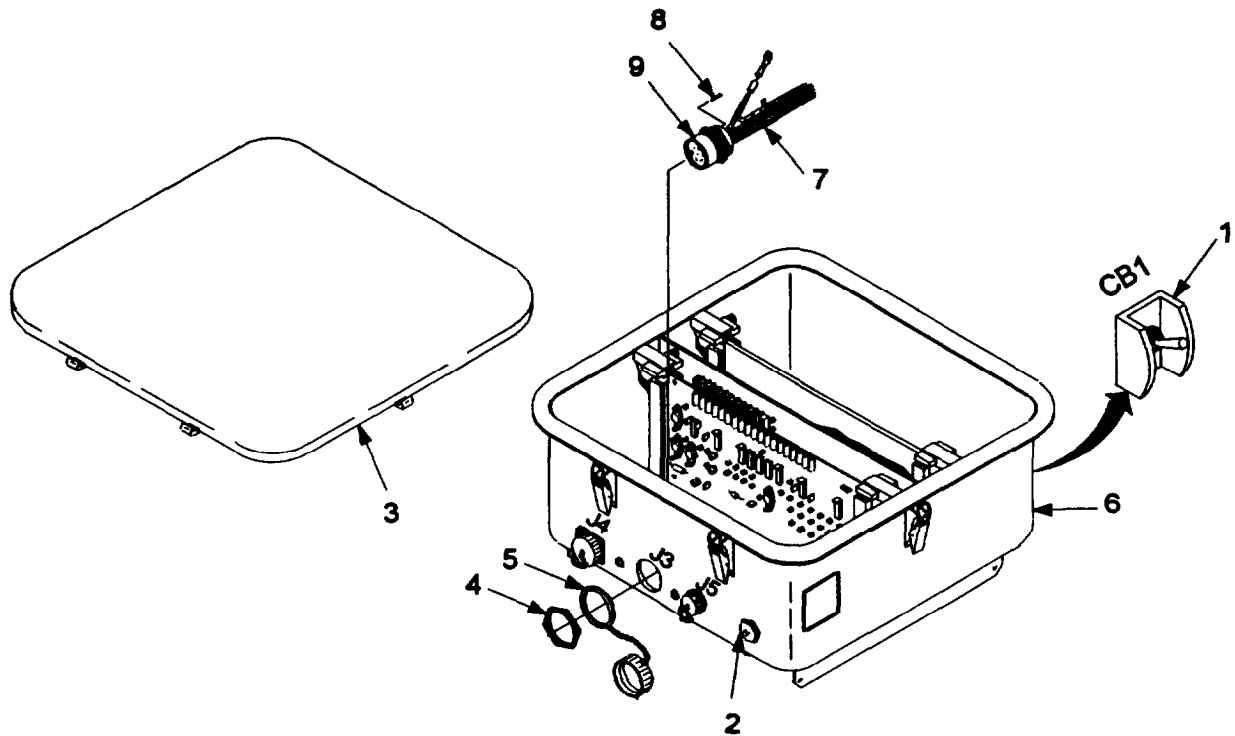

- m. Install connector sealing plugs in rear of connector.
- n. Apply sealing compound to threads, apply grease to O-ring groove (9) and install connector in housing.
- o. Install link chain assembly and torque connector mounting nut to 55-60 pound-inches (6.26-6.83 newton-meters).
- p. Install power supply. Refer to paragraph 4-8.
- q. Apply a uniform, thin coating of grease to entire gasket surface.
- r. Install cover assembly and fasten latches.
- s. Set CB1 of ICB/Low Power to the ON position.
- t. Set TIU CB1 to the ON position.
- u. Test in accordance with TM 9-6920-742-14-1.

## 5-15 TIU CONNECTOR J5 REPLACEMENT (MS3474W14-9P).

### INITIAL SETUP

#### Tools and Special Tools:

General mechanic's automotive tool kit  
Wire strippers  
Crimping tool  
Torque wrench

#### Materials/Parts:

Connector (MS3474W14-9P)  
Grease (item 2, appendix D)  
Sealing compound (item 9, appendix D)

#### References:

Power supply removal  
(reference paragraph D)  
TM 9-6920-742-14-1

---

- a. Set CB1 of ICB/Low Power to the OFF position.
- b. Set TIU CB1 (1) to the OFF position.

### WARNING

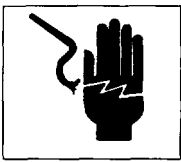

**When working inside the equipment after power has been turned off, always ground every part before touching it. Failure to do so could result in serious injury or death.**

- c. Depress pressure relief valve (2) to equalize pressure before removing cover assembly.
- d. Release latches and remove cover assembly (3).
- e. Remove power supply. Refer to paragraph 4-8.
- f. Remove connector mounting nut (4) and link chain assembly (5).
- g. Remove connector from housing (6).
- h. Tag all connector leads (7) and remove leads and crimped pins (8) from rear of connector.
- i. Cut leads as close to crimped pins as possible.
- j. Strip leads back 3/16-inch (.477 cm).
- k. Crimp new pins onto stripped leads.
- l. Insert pins in rear of connector.



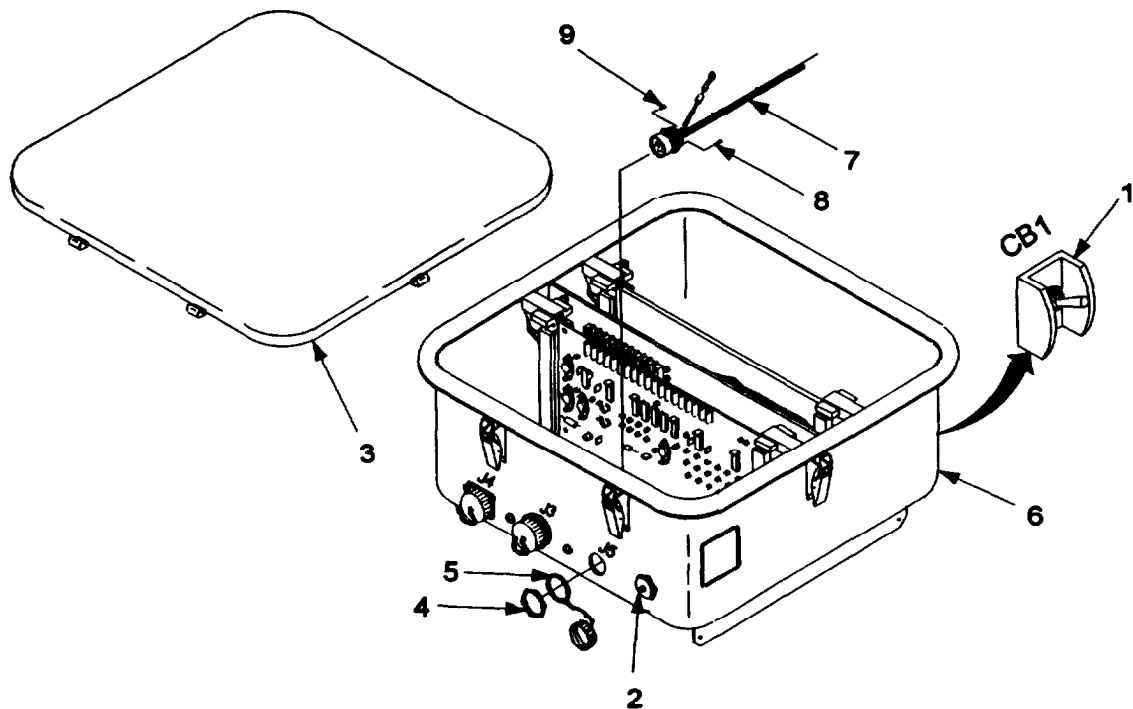

- m. Install connector sealing plugs in rear of connector.
- n. Apply sealing compound to threads, apply grease to O-ring groove (9) and install connector in housing.
- o. Install link chain assembly and torque connector mounting nut to 55-60 pound-inches (6.26-6.83 newton-meters).
- p. Install power supply. Refer to paragraph 4-8.
- q. Apply a uniform, thin coating of grease to entire gasket surface.
- r. Install cover assembly and fasten latches.
- s. Set CB1 of ICB/Low Power to the ON position.
- t. Set TIU CB1 to the ON position.
- u. Test in accordance with TM 9-6920-742-14-1.

**5-16 TIU CONNECTOR XA1 REPLACEMENT (9353914).**

**INITIAL SETUP**

**Tools and Special Tools:**

General mechanic's automotive tool kit  
Heat gun  
Soldering and desoldering set  
Wire strippers

**Materials/Parts:**

Connector (9353914)  
Insulation sleeving (M23053/5-102-0)  
Solder (item 11, appendix D)

**References:**

TM 9-6920-742-14-1

**Equipment Conditions:**

Wiring harness removed  
(reference paragraph 5-10)

- a. Remove insulation sleeving (1).
- b. Tag, desolder, and remove all leads (2) from connector XA1 (3).
- c. Install insulation sleeving on all leads.
- d. Using tags as reference, install all leads to correct pins on connector XA1.
- e. Solder leads in place.
- f. Slide insulation sleeving over connections.
- g. Apply heat and shrink in place.
- h. Install wiring harness. Refer to paragraph 5-10.
- i. Test in accordance with TM 9-6920-742-14-1.

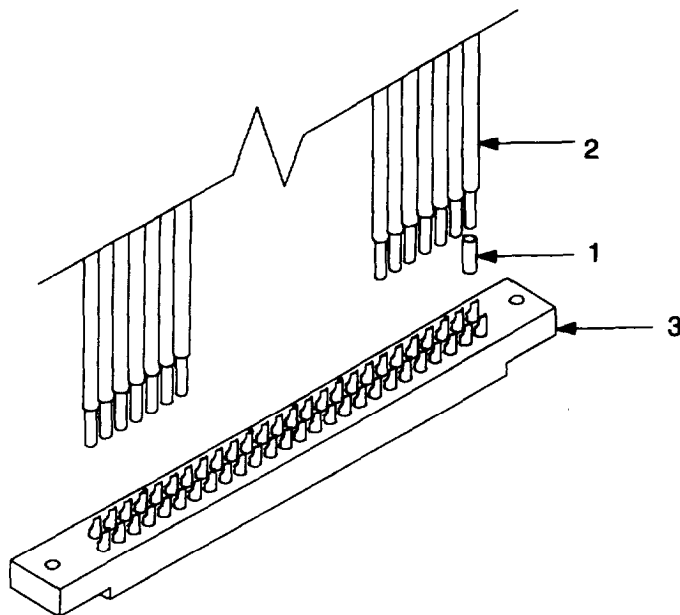

**THIS PAGE INTENTIONALLY LEFT BLANK**

**5-17 TIU TERMINAL LUG REPLACEMENT (MS25036-106).**

**INITIAL SETUP**

**Tools and Special Tools:**

General mechanic's automotive tool kit  
Wire strippers  
Crimping tool

**Materials/Parts:**

Terminal lug (MS25036-106)

**References:**

TM 9-6920-742-14-1

---

- a. Set CB1 of ICB/Low Power to the OFF position.
- b. Set TIU CB1 (1) to the OFF position.

**WARNING**

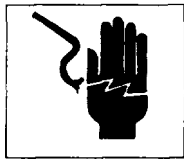

**When working inside the equipment after power has been turned off, always ground every part before touching it. Failure to do so could result in serious injury or death.**

- c. Depress pressure relief valve (2) to equalize pressure before removing cover assembly.
- d. Release latches and remove cover assembly (3).
- e. Release control logic CCA keepers (4).
- f. Unplug control logic CCA (5) from connector.
- g. Release ETISD CCA keepers (6).
- h. Unplug ETISD CCA (7) from connector.
- i. Tag all terminal leads on A1TB1 (8), A1TB2 (9), and A2TB1 (10).
- j. Remove screws and lockwashers and remove terminal leads to be replaced.
- k. Cut terminal lugs from leads.
- l. Strip leads back 3/16 inch (.477 cm).
- m. Insert leads into terminal lugs and crimp tight.
- n. Install terminal lugs on terminal board and secure with screws and lo&washers.

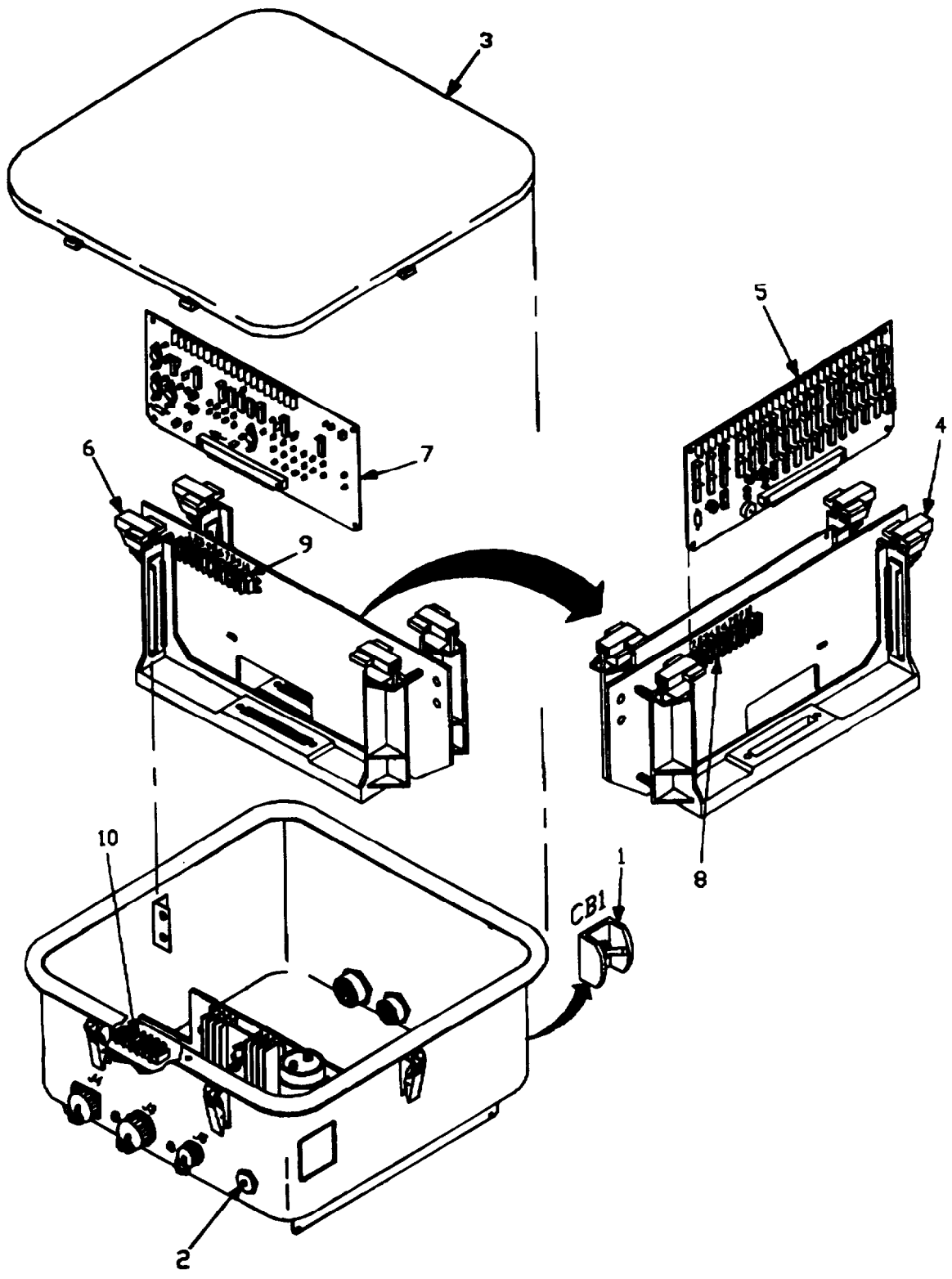

**5-18 TIU TERMINAL LUG REPLACEMENT (MS25036-102).**

**INITIAL SETUP**

**Tools and Special Tools:**

General mechanic's automotive tool kit  
Wire strippers  
Crimping tool

**Materials/Parts:**

Terminal lug (MS25036-102)

**References:**

TM 9-6920-742-14-1

---

- a. Set CB1 of ICB/Low Power to the OFF position.
- b. Set TIU CB1 (1) to the OFF position.

**WARNING**

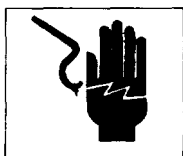

**When working inside the equipment after power has been turned off, always ground every part before touching it. Failure to do so could result in serious injury or death.**

- c. Depress pressure relief valve (2) to equalize pressure before removing cover assembly.
- d. Release latches and remove cover assembly (3).
- e. Release control logic CCA keepers (4).
- f. Unplug control logic CCA (5) from connector.
- g. Release ETISD CCA keepers (6).
- h. Unplug ETISD CCA (7) from connector.
- i. Remove screw (8), self-locking nut (9), and flatwasher (10) and remove terminal lug.
- j. Cut terminal lug from leads.
- k. Strip leads back 3/16 inch (.477 cm).
- l. Insert leads into terminal lug and crimp tight.
- m. Install terminal lug on center plate and secure with screw, flatwasher, and self-locking nut.
- n. Test in accordance with TM 9-6920-742-14-1.

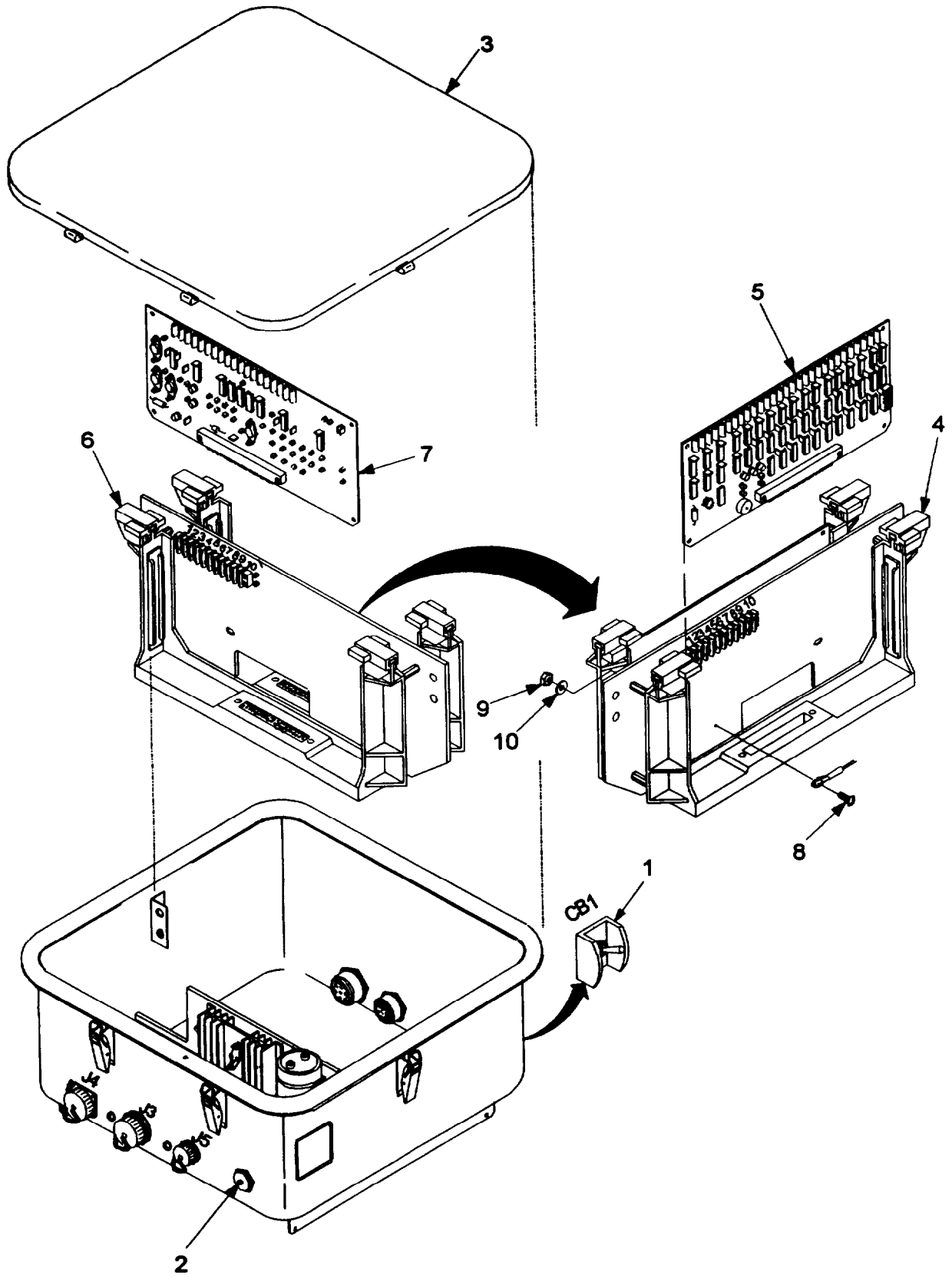

**5-19 TIU TERMINAL LUG REPLACEMENT (MS25036-150).**

**INITIAL SETUP**

**Tools and Special Tools:**

- General mechanic's automotive tool kit
- Wire strippers
- Crimping tool

**Materials/Parts:**

- Terminal lug (MS25036-150)

**References:**

- TM 9-6920-742-14-1

- a. Set CB1 of ICB/Low Power to the OFF position.
- b. Set TIU CB1 to the OFF position.

**WARNING**

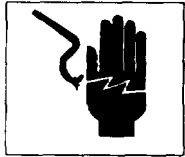

When working inside the equipment after power has been turned off, always ground every part before touching it. Failure to do so could result in serious injury or death.

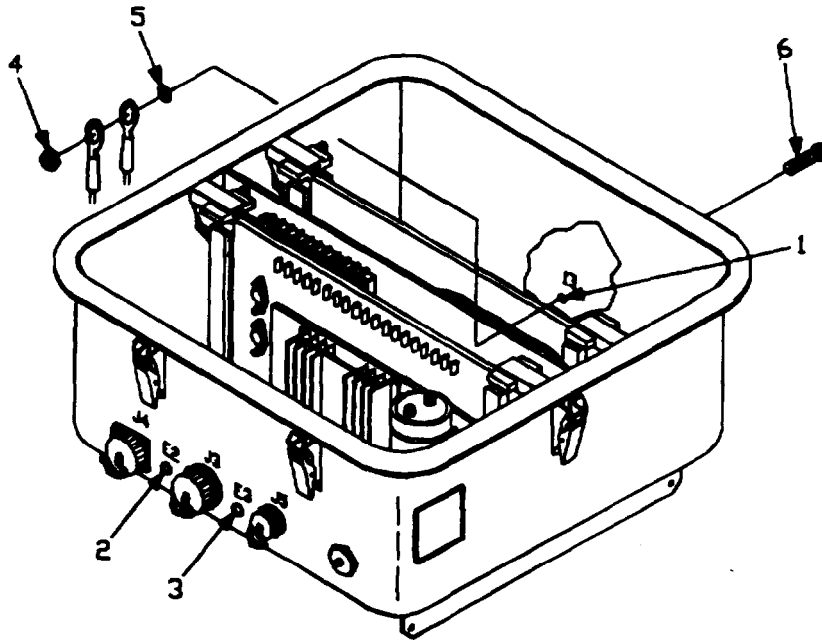



- c. Depress pressure relief valve to equalize pressure before removing cover assembly.
- d. Release latches and remove cover assembly.
- e. Tag ground leads on terminal lugs to be replaced on E1 (1), E2 (2), or E3 (3).
- f. Remove self-locking nuts (4) and flatwashers (5) from ground studs (6).
- g. Cut terminal lugs from leads.
- h. Strip leads back 3/16 inch (.477 cm).
- i. Insert leads into terminal lugs and crimp tight.
- j. Install terminal lugs on ground studs and secure with self-locking nuts and flatwashers.
- k. Test in accordance with TM 9-6920-742-14-1.

**5-20 TIU CONNECTOR XA2 REPLACEMENT (M55302/58A70X).**

**INITIAL SETUP**

**Tools and Special Tools:**

General mechanic's automotive tool kit  
Heat gun  
Soldering and desoldering set  
Wire strippers

**Materials/Parts:**

Connector (M55302/58A70X)  
Insulation sleeving (M23053/5-102-0)  
Solder (item 11, appendix D)

**References:**

TM 9-6920-742-14-1

**Equipment Conditions:**

Wiring harness removed  
(reference paragraph 5-10)

- a. Remove insulation sleeving (1).
- b. Tag, desolder, and remove all leads (2) from connector XA2 (3).
- c. Install insulation sleeving on all leads.

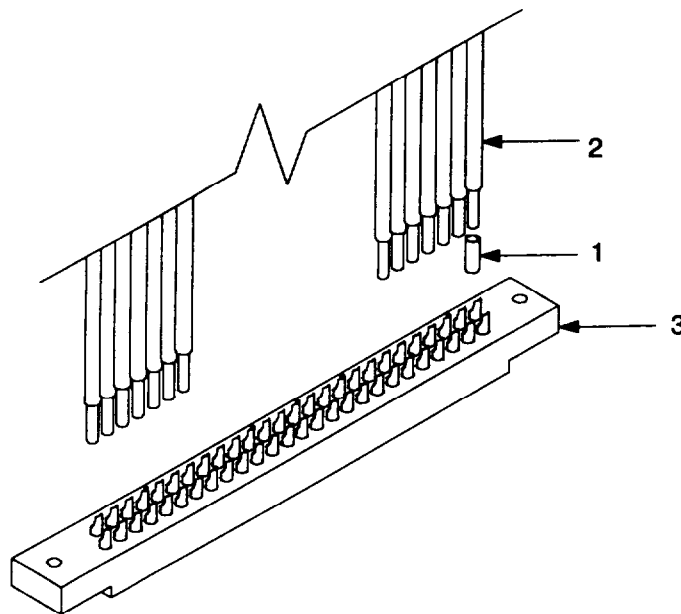

- d. Using tags as reference, install all leads to correct pins on connector XA2.
- e. Solder leads in place.
- f. Slide insulation sleeving over connections.
- g. Apply heat and shrink tight.
- h. Install wiring harness. Refer to paragraph 5-10.
- i. Test in accordance with TM 9-6920-742-14-1.

**5-21 TIU WIRING HARNESS REPLACEMENT (9353958).****INITIAL SETUP****Tools and Special Tools:**

General mechanic's automotive tool kit  
Torque wrench

**References:**

TM 9-6920-742-14-1

**Materials/Parts:**

Wiring harness (9353958)  
Self-locking nut (NAS679C04M)  
Self-locking nut (NAS679C06M)  
Grease (item 2, appendix D)  
Sealing compound (item 9, appendix D)  
Adhesive (item 10, appendix D)

**a. Removal.**

- (1) Set CB1 of ICB/Low Power to the OFF position.
- (2) Set TIU CB1 to the OFF position.

**WARNING**

**When working inside the equipment after power has been turned off, always ground every part before touching it. Failure to do so could result in serious injury or death.**

- (3) Depress pressure relief valve to equalize pressure before removing cover assembly.
- (4) Release latches and remove cover assembly.
- (5) Release ETISD CCA keepers (1).
- (6) Unplug ETISD CCA (2) from connector.
- (7) Tag leads from TB2 (3) terminals 1, 6, and 10.
- (8) Remove screws and lo&washers from TB2 terminals 1, 6, and 10.
- (9) Remove self-locking nut (4) and flatwasher (5) from E2.
- (10) Disconnect ground lead from E2.
- (11) Remove four self-locking nuts (6), eight flatwashers (7), and four screws (8) from J4 connector (9).
- (12) Remove J4 connector, link chain attachment, and gasket from housing.
- (13) Pull wiring harness from under center plate and remove from housing.

5-21 TIU WIRING HARNESS REPLACEMENT (9353958) (CONTINUED).

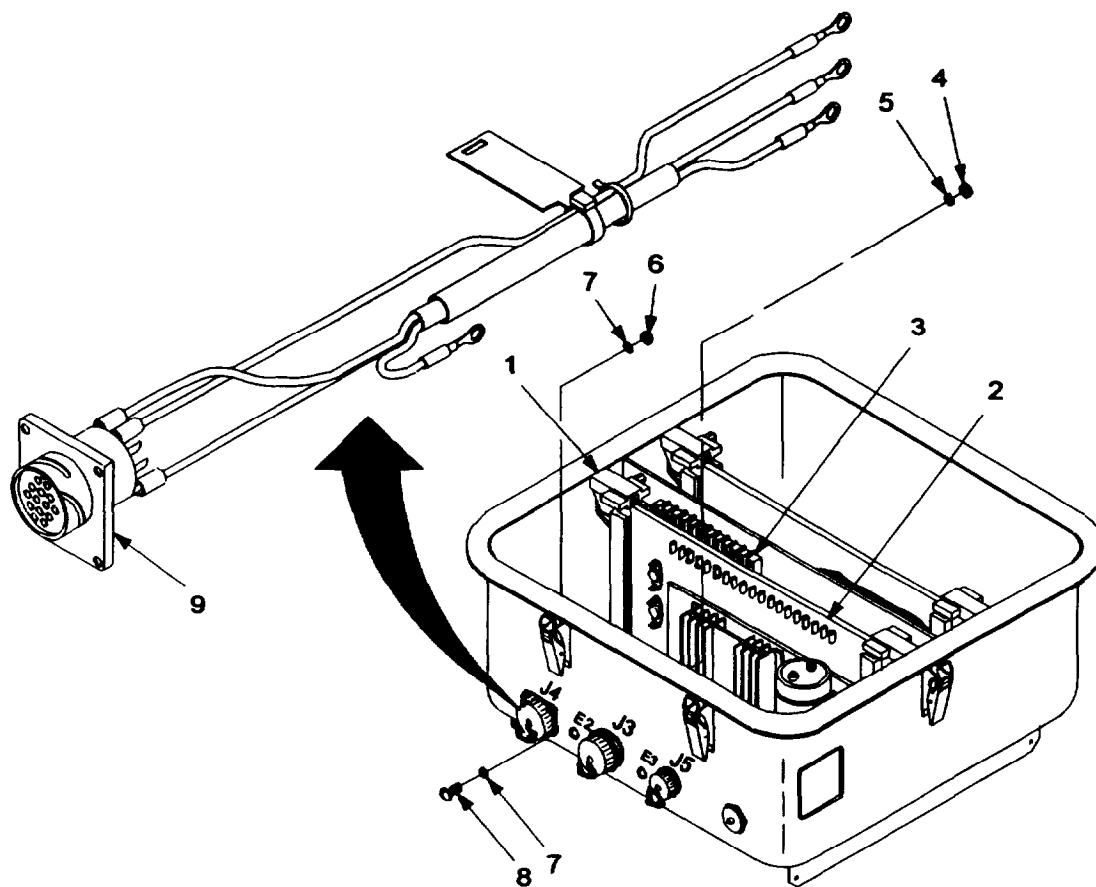

**b. Installation.**

- (1) Apply sealing compound to threads, install J4 connector (9), gasket and link chain attachment into housing.
- (2) Install four screws (8), eight flatwashers (7), and four new self-locking nuts (6) and torque to 7-9 inch pounds.
- (3) Apply silicone rubber over inside ends of screws and self-locking nuts.
- (4) Install ground lead to E2 and secure with flatwasher (5) and new self-locking nut (4).
- (5) Route wiring harness under the center plate.
- (6) Install leads to TB2 (3) terminals 1, 6, and 10.
- (7) Secure leads to TB2 with screws and lockwashers.
- (8) Plug ETISD CCA (2) into connector.

- (9) Fasten ETISD CCA keepers (1).
- (10) Apply a uniform, thin coating of grease to entire gasket surface.
- (11) Install cover assembly and fasten latches.
- (12) Set CB1 of ICB/Low Power to the ON position.
- (13) Set TIU CB1 to the ON position.
- (14) Test in accordance with TM 9-6920-742-14-1.

## 5-22 ASSEMBLY OF TIU WIRING HARNESS ASSEMBLY (9353958).

### INITIAL SETUP

#### Tools and Special Tools:

General mechanic's automotive tool kit  
Soldering and desoldering set  
Heat gun  
Wire strippers  
Crimping tool

#### Materials/Parts:

Cable (EC16U0-9STW)  
Connector (11784667)  
Identification marker (9387201)

#### Materials/Parts (Continued):

Insulation sleeving (M23053/5-105-0)  
Insulation sleeving (M23053/5-106-0)  
Splice conductor (9341118)  
Terminal lug (MS25036-106)  
Terminal lug (MS25036-150)  
Tiedown strap (MS3368-1-9B)  
Wire (M16878/4BFE5)  
Wire (M16878/4BJE2)  
Solder (item 11, appendix D)

### NOTE

**When building cable assemblies and wiring harnesses, markers are provided for the completed assemblies. Using the same markers on small gauge wires may not be practical. Small gauge wire may be identified by reusing serviceable original wire markers, by marking the appropriate size insulation sleeving with the necessary information, or by any other practical method.**

- a. Cut cable to 16.00-inch (40.6 cm) length.
- b. Strip outer insulation and shield back 1.5 inches (3.81 cm) from one end of cable.
- c. Strip inner insulation back 1/4 inch (.635 cm).
- d. Slide insulation sleeving (1)(M23053/5-105-0) over ends of both wires.
- e. Install black lead (2) to connector terminal A and white lead (3) to connector terminal N.
- f. Solder leads to connector.

5-22 ASSEMBLY OF TIU WIRING HARNESS ASSEMBLY (9353958) (CONTINUED).

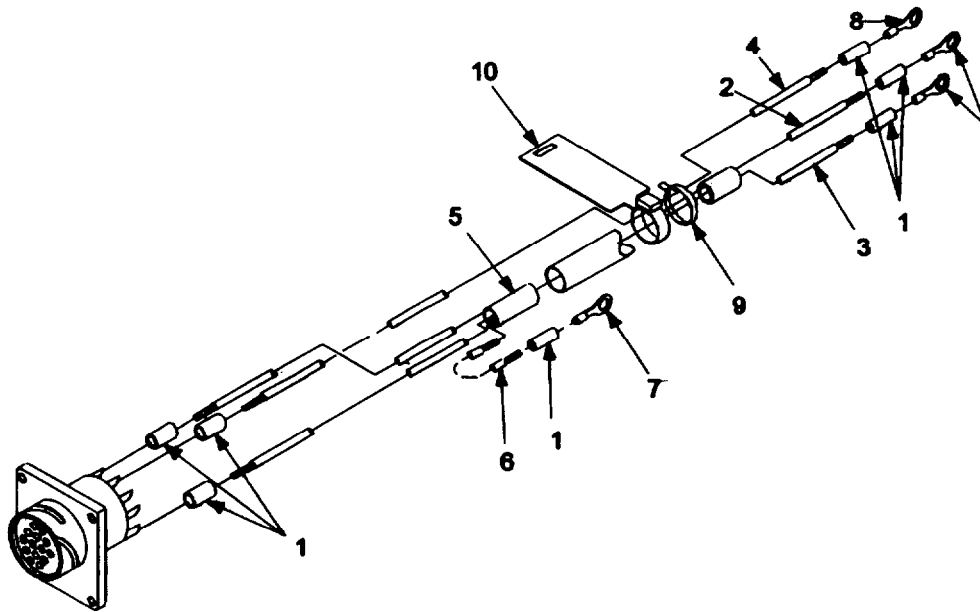

- g. Cut red wire (4) to 17.50-inch (44.45 cm) length.
- h. Strip insulation back 1/4 inch (.635 cm) from one end.
- i. Slide insulation sleeving (M23053/5-105-0) over end of wire.
- j. Install red lead to connector terminal K.
- k. Solder lead to connector.
- l. Apply heat to all insulation sleeving and shrink tight.
- m. Strip outer insulation of cable (connector end) 1/2 inch (1.27 cm) to expose shield.
- n. Install splice connector (5) to exposed cable shield.
- o. Cut green wire (6) to 4.00-inch (10.16 cm) length.
- p. Strip insulation back 1/4 inch (.635 cm) from both ends.
- q. Install one end of green wire into splice connector.
- r. Crimp splice connector to cable shield and green wire.
- s. Install terminal lug (7)(MS25036-150) to green wire and crimp tight.
- t. Strip back 6.00 inches (15.24 cm) of outer insulation and shield from cable.
- u. Slide insulation sleeving (M23053/5106-0) over cable.

- v. Cut 2.00 inches (5.08 cm) from white wire.
- w. Strip insulation back 1/4 inch (.635 cm) from ends of wires.
- x. Install terminal lugs (8)(MS25036-106) to ends of wires and crimp tight.
- y. Install tiedown straps (9) to assembly as required.
- z. Install identification marker (10) to assembly.

**5-23 TIU CABLE W107 (9363165) CONNECTOR P3 REPLACEMENT (117846681.**

**INITIAL SETUP**

**Tools and Special Tools:**

- General mechanic's automotive tool kit
- Wire strippers
- Crimping tool
- Insertion/extraction tool (k/M81969/14-03)

**Materials/Parts:**

- Connector (11784668)
- Sealing compound (item 8, appendix D)

**References:**

- TM 9-6920-742-14-1

- a. Set CB1 of ICB/Low Power to the OFF position.
- b. Set TIU CB1 to the OFF position.
- c. Disconnect cable connectors P2, P3, and P4 from supported equipment.

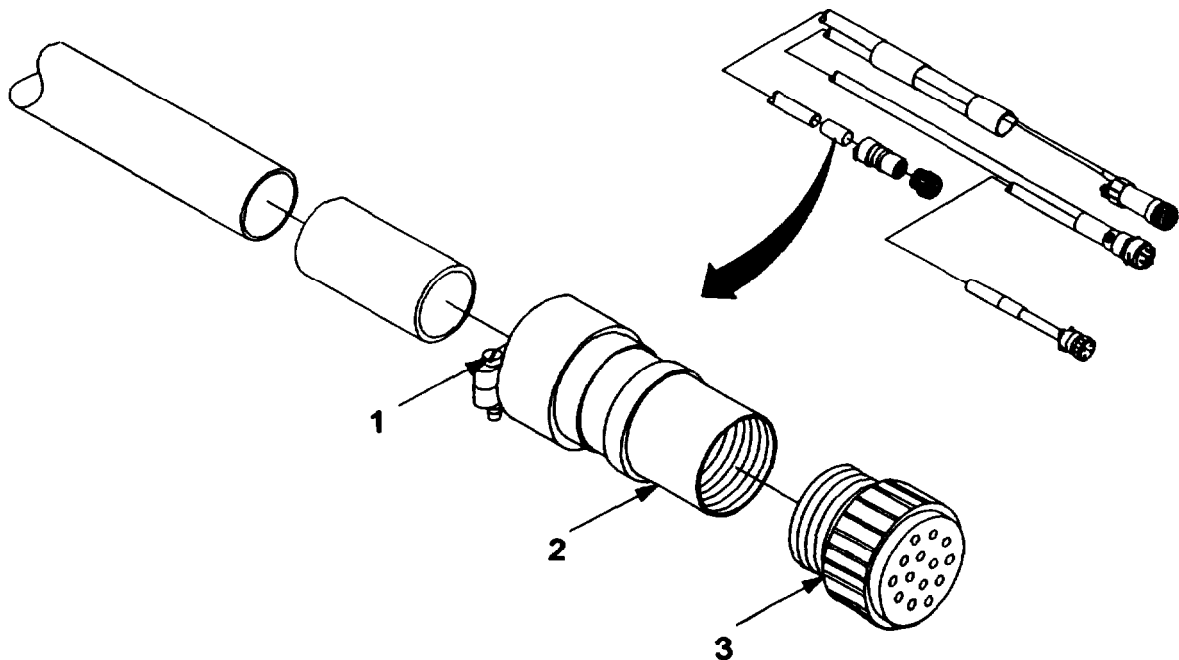

**5-23 TIU CABLE W107 (9363185) CONNECTOR P3 REPLACEMENT (11784668) (CONTINUED).**

- d. Disconnect cable connector P1 from J3 on TIU.
- e. Loosen two screws (1) on backshell strain relief of P3 connector.
- f. Unscrew backshell (2) and separate from connector (3).
- g. Tag leads from rear of connector.
- h. Cut leads as close to pins as possible.
- i. Strip leads back 3/16-inch (.477 cm).
- j. Insert leads (4) into new pins (5) and crimp.
- k. Using insertion/extraction tool (6), install pins into rear of connector.

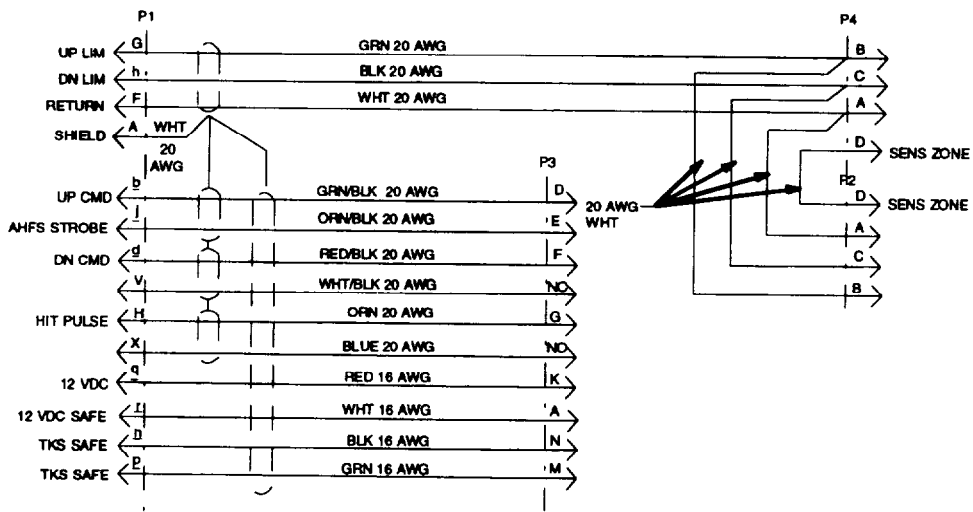
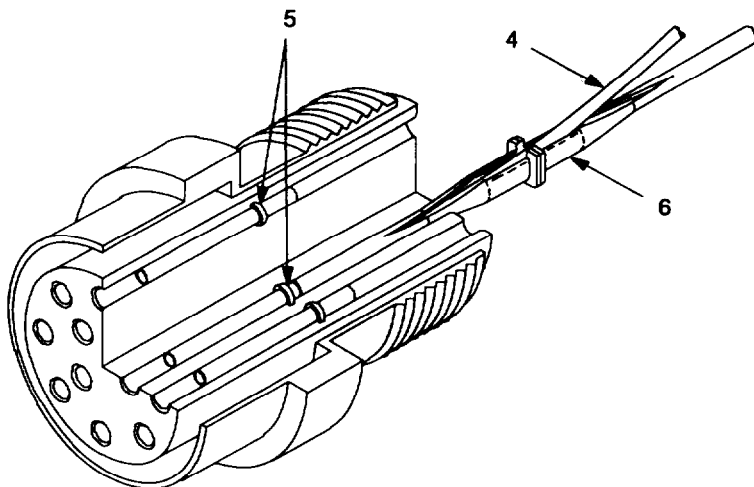

**WIRING DIAGRAM**



- l. Apply sealing compound to threads and install backshell to connector.
- m. Tighten two screws on backshell strain relief.
- n. Install cable connector P1 to J3 on TIU.
- o. Install cable connectors P2, P3, and P4 to supported equipment.
- p. Set CB1 of the ICB/Low Power to the ON position.
- q. Set TIU CB1 to the ON position.
- r. Test in accordance with TM 9-6920-742-14-1.

**5-24 TIU CABLE W107 (9363185) CONNECTOR P2 REPLACEMENT (11784662).**

**INITIAL SETUP**

**Tools and Special Tools:**

- General mechanic's automotive tool kit
- Wire strippers
- Soldering and desoldering set
- Insertion/extraction tool (M81969/14-03)

**Materials/Parts:**

- Connector (11784662)
- Sealing compound (item 8, appendix D)

**References:**

- TM 9-6920-742-14- 1

- a. Set CB1 of ICB/Low Power to the OFF position.

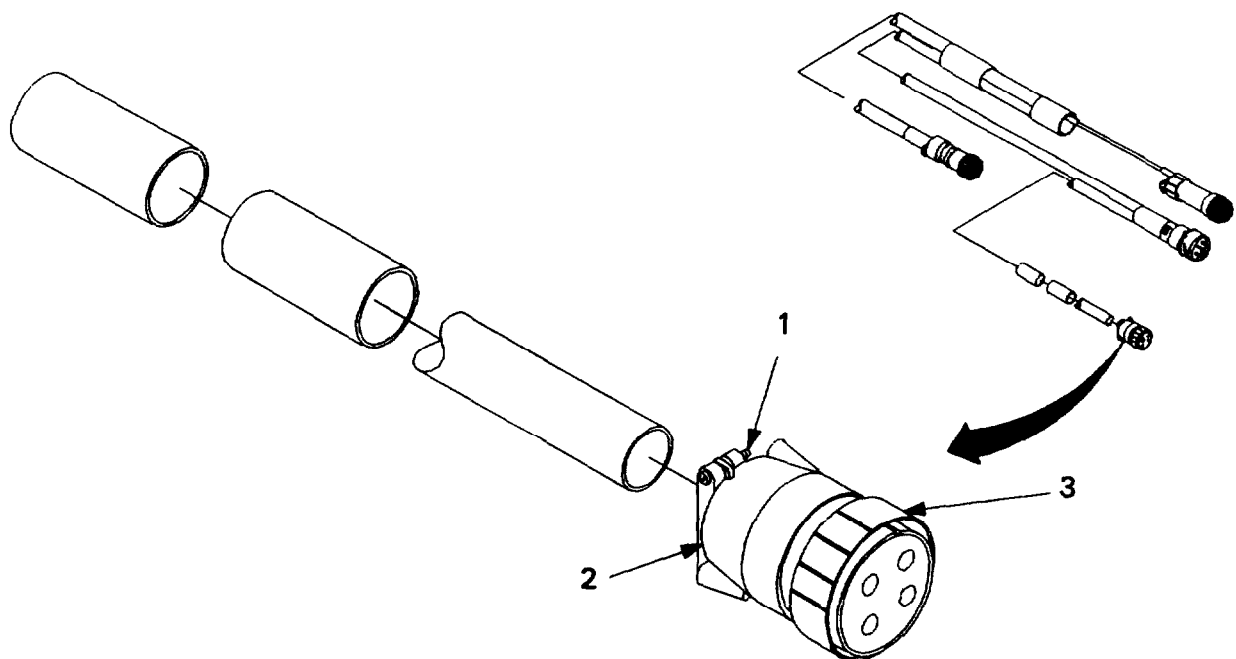

**5-24 TIU CABLE W107 (9363185) CONNECTOR P2 REPLACEMENT (11784662) (CONTINUED).**

- b. Set TIU CB1 to the OFF position.
- c. Disconnect cable connectors P2, P3, and P4 from supported equipment.
- d. Disconnect cable connector P1 from J3 on TIU.
- e. Remove two screws (1) and strain relief (2) from P2 connector (3).
- f. Tag leads from rear of connector.
- g. Cut leads as close to pins as possible.
- h. Install insulation sleeving over leads.

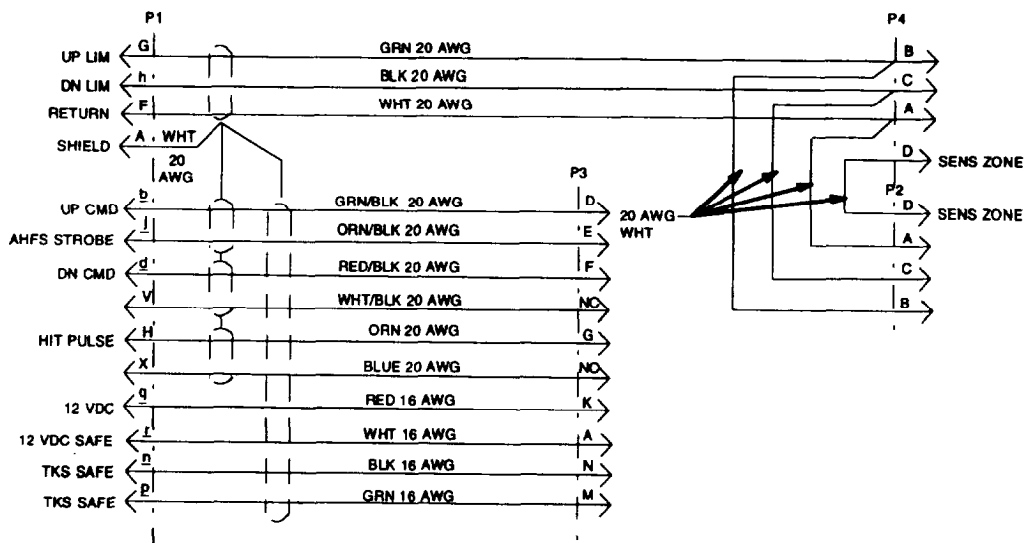
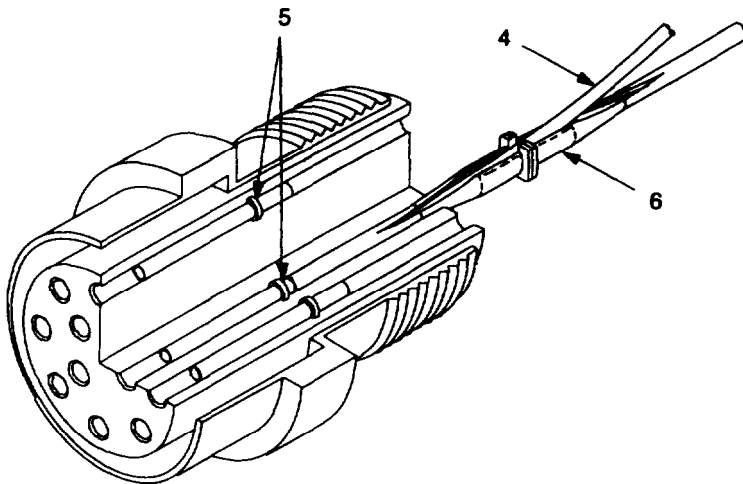

**WIRING DIAGRAM**

- i. Strip leads back 3/16-inch (.477 cm).
- j. Insert leads (4) into new pins (5) and solder in place.
- k. Using insertion/extraction tool (6), install pins into rear of connector.
- l. Tighten two screws on backshell strain relief.
- m. Install cable connector P1 to J3 on TIU.
- n. Install cable connectors P2, P3, and P4 to supported equipment.
- o. Set CB1 of the ICB/Low Power to the ON position.
- p. Set TIU CB1 to the ON position.
- q. Test in accordance with TM 9-6920-742-14-1.

**5-25 ICB/HIGH POWER REPLACEMENT (9353786).**

**INITIAL SETUP**

**Tools and Special Tools:**

General mechanic's automotive tool kit

**Personnel Required:**

2 persons (for safety purposes)

**Materials/Parts:**

ICB/High Power (9353786)

**References:**

TM 9-6920-742-14-1

**a. Removal.**

- (1) Set CB1 (1) of ICB/High Power to the OFF position.
- (2) Remove power from 240 vac incoming power line.

**WARNING**



**When working Inside the equipment after power has been turned off, always ground every part before touching it. Failure to do so could result in serious injury or death.**

- (3) Release latches and remove cover assembly.
- (4) Loosen four screws, tag and remove 240 vac incoming power leads from TB5 terminals 1 (2) and 2 (3), E7 (4), and E8 (5).

**5-25 ICB/HIGH POWER REPLACEMENT (9353786) (CONTINUED).**

- (5) Remove screws and lockwashers from TB3 (6) terminals 2, 3, 4, 5, 8, 9, and chassis ground.
- (6) Tag and remove cable W102-2 (7) leads from TB3.
- (7) Remove screws and lockwashers from TB1 (8) terminals 3, 4, 5, 6, 7, 8, 9, and 10.
- (8) Tag and remove incoming data leads (9) from TB1.
- (9) Tag and remove cable W101-2 leads (10) from TB7 (11).
- (10) Remove nut, washer, and switch guard from CB1.
- (11) Remove CB1 from housing assembly.
- (12) Remove mounting hardware securing mounting plate to housing assembly.

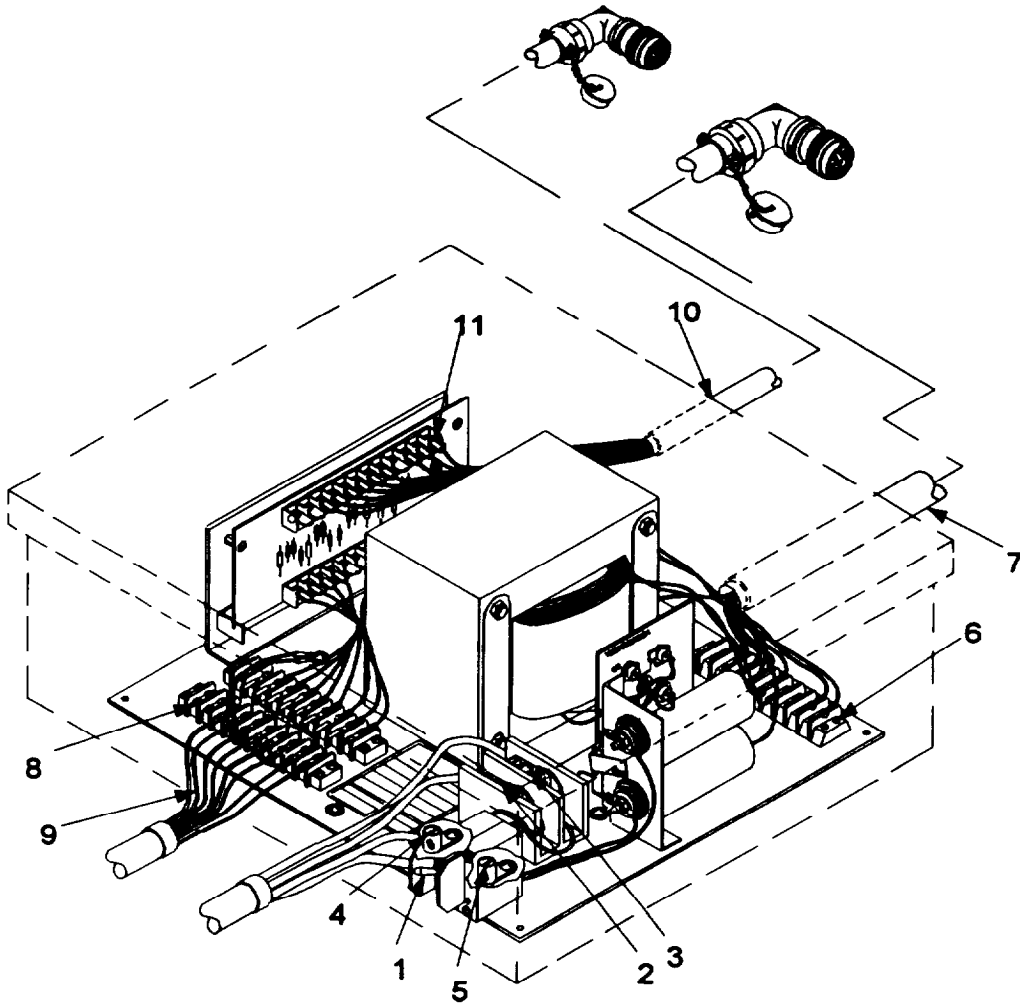

**WARNING**

Mounting plate assembly contains transformer which weighs approximately 40 pounds (18.16 kilograms). Use proper lifting procedures when removing or installing. Failure to do so could result in serious bodily injury.

- (13) Remove mounting plate from housing assembly.

**b. Installation.**

- (1) Ensure CB1 (1) is in the OFF position.  
 (2) Remove power from 240 vac incoming power line.

**WARNING**

When working inside the equipment after power has been turned off, always ground every part before touching it. Failure to do so could result in serious injury or death.

- (3) Release latches and remove cover assembly.

**WARNING**

Mounting plate assembly contains transformer which weighs approximately 40 pounds (18.16 kilograms). Use proper lifting procedures when removing or installing. Failure to do so could result in serious bodily injury.

- (4) Install mounting plate into housing assembly.  
 (5) Install mounting hardware securing mounting plate to housing assembly.  
 (6) Install CB1 into housing assembly.  
 (7) Install switch guard, washer and nut securing CB1 to housing assembly.  
 (8) Install cable W101-2 leads (10) to TB7 (11).

**5-25 ICB/HIGH POWER REPLACEMENT (9353786) (CONTINUED).**

**NOTE**

**Ensure that jumper connection is in place between TB1 terminals 6 and 7 prior to installing screws and lockwashers**

- (9) Install incoming data lines (9) to TB1 (8) terminals 3, 4, 5, 6, 7, 8, 9, and 10 and secure with screws and lockwashers.
- (10) Install cable W102-2 (7) leads to TB3 (6) terminals 2, 3, 4, 5, 8, 9, and chassis ground and secure with screws and lockwashers.
- (11) Install incoming 240 vac power leads to TB5 terminals 1 (2) and 2 (3), E7 (4), and E8 (5).
- (12) Install cover assembly and fasten latches.
- (13) Apply power to incoming 240 vac power line.
- (14) Set CB1 to the ON position.
- (15) Test in accordance with TM 9-6920-742-14-1.

**5-26 ICB/HIGH POWER EMI FILTER REPLACEMENT (9353813).**

**INITIAL SETUP**

**Tools and Special Tools:**

General mechanic's automotive tool kit

**Personnel Required:**

2 persons (for safety purposes)

**Materials/Parts:**

EMI filter (9353813)

**References:**

TM 9-6920-742-14-1

---

**a. Removal**

- (1) Set CB1 to the OFF position.
- (2) Remove power from 240 vac incoming power line.

**WARNING**

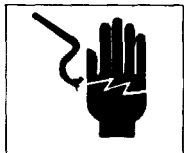

**When working inside the equipment after power has been turned off, always ground every part before touching it. Failure to do so could result in serious injury or death.**

- (3) Release latches and remove cover assembly.

- (4) Remove two nuts (1) and lockwashers (2) from input ends of EMI filters (3).
- (5) Tag and remove two CB1 load leads (4) and two gas tube arrestor leads (5) from EMI filters.

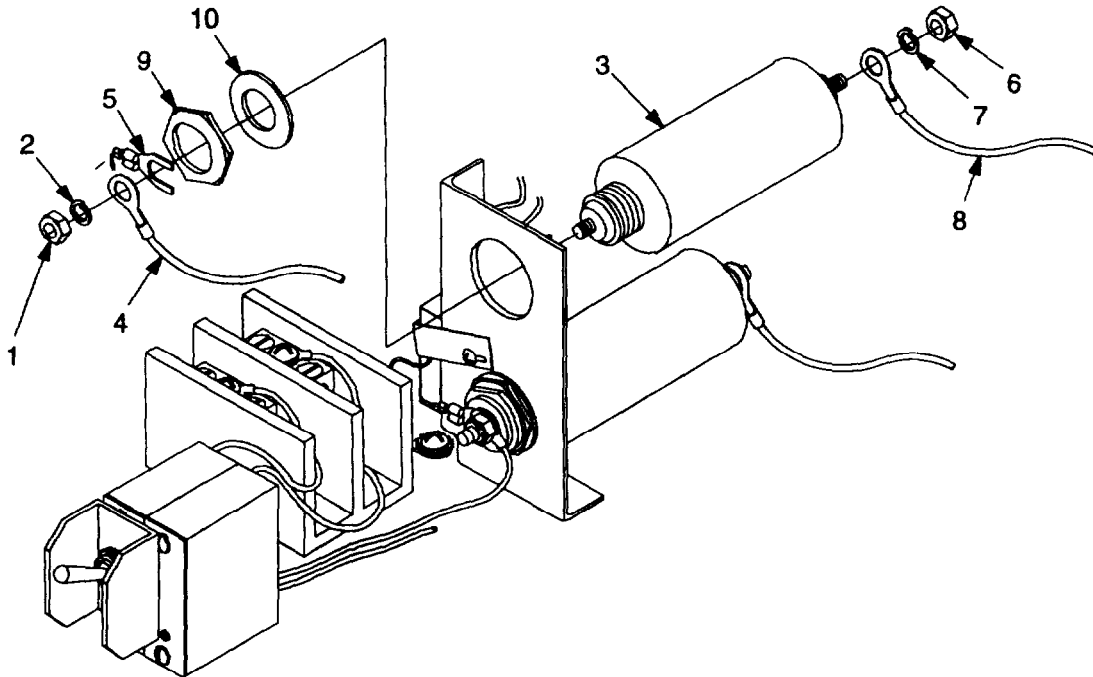

- (6) Remove two nuts (6) and lockwashers (7) from output ends of EMI filters.
- (7) Tag and remove two transformer leads (8) from EMI filters.
- (8) Remove nuts (9) and lockwashers (10) securing EMI filters to mounting bracket.
- (9) Remove EMI filters from bracket.

**b. Installation.**

- (1) Install EMI filters (3) to mounting bracket and secure with nuts (9) and lockwashers (10).
- (2) Install two transformer leads (8) to output ends of EMI filters and secure with two nuts (6) and lockwashers (7).
- (3) Install two CB1 load leads (4) and two gas tube arrestor leads (5) to input ends of EMI filters and secure with two nuts (1) and lockwashers (2).
- (4) Install cover assembly and fasten latches.
- (5) Apply power to incoming 240 vac power line.
- (6) Set CB1 to the ON position.
- (7) Test in accordance with TM 9-6920-742-14-1.

5-27 ICB/HIGH POWER GAS TUBE ARRESTOR REPLACEMENT(9353905).

INITIAL SETUP

**Tools and Special Tools:**

General mechanic's automotive tool kit

**Personnel Required:**

2 persons (for safety purposes)

**Materials/Parts:**

Gas tube arrestor (9353995)

**References:**

TM 9-6920-742-14-1

---

**a. Removal.**

- (1) Set CB1 to the OFF position.
- (2) Remove power from 240 vac incoming power line.

**WARNING**



**When working inside the equipment after power has been turned off, always ground every part before touching it. Failure to do so could result in serious injury or death.**

- (3) Release latches and remove cover assembly.
- (4) Loosen nuts (1) on input end of EMI filters (FL1 and FL2).
- (5) Remove gas tube arrestor leads (2) from FL1 and FL2.
- (6) Remove screw (3) and lockwasher (4) and remove gas tube arrestor ground lead (5) from E6.
- (7) Loosen screw (6) securing gas tube arrestor mounting bracket (7) and slide bracket aside.
- (8) Remove gas tube arrestor (8).

**b. Installation.**

- (1) Install gas tube arrestor (8) under mounting bracket (7).
- (2) Slide bracket against gas tube arrestor and tighten screw (6).
- (3) install gas tube arrestor ground lead (5) to E6 and secure with screw (3) and lockwasher (4).
- (4) Install ends of gas tube arrestor leads (2) under lockwashers on input ends of FL1 and FL2 and tighten nuts (1) to secure.



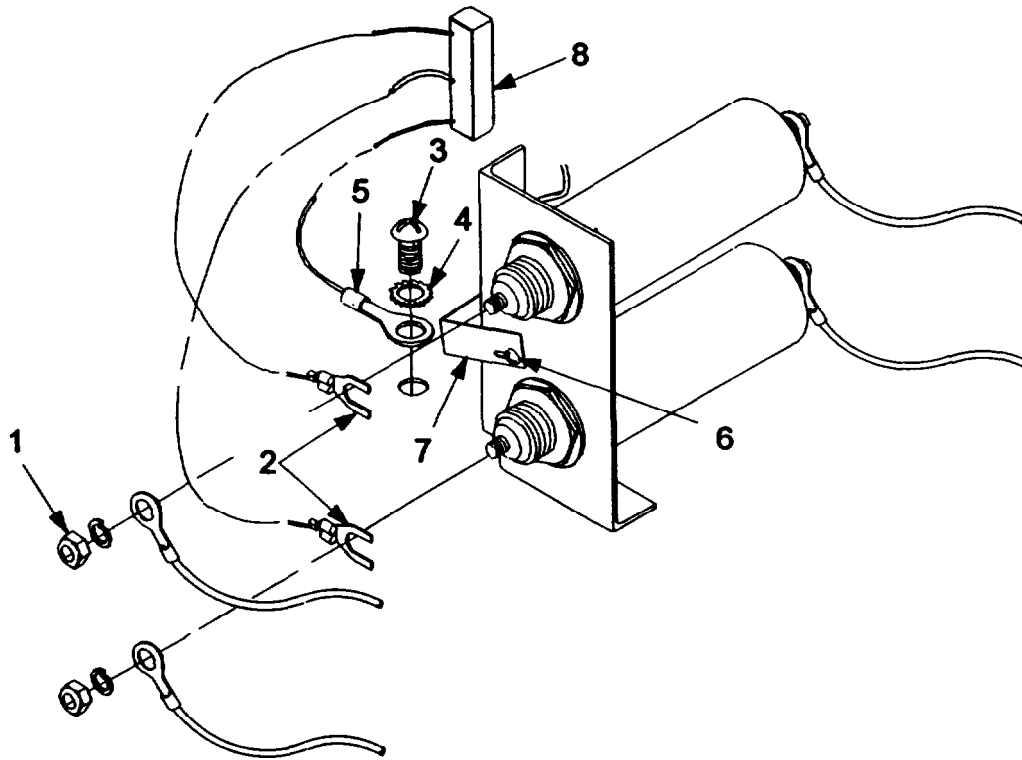

- (5) Install cover assembly and fasten latches.
- (6) Apply power to 240 vac incoming power line.
- (7) Set CB1 to the ON position.
- (8) Test in accordance with TM 9-6920-742-14-1.

**5-28 ICB/HIGH POWER SUPPRESSION BOARD REPLACEMENT (9353854).**

**INITIAL SETUP**

**Tools and Special Tools:**

General mechanic's automotive tool kit

**Personnel Required:**

2 persons (for safety purposes)

**Materials/Parts:**

Suppression board (9353854)

**References:**

TM 9-6920-742-14-1

---

**a. Removal.**

- (1) Set CB1 to the OFF position.
- (2) Remove power from 240 vac incoming power line.

**WARNING**



**When working inside the equipment after power has been turned off, always ground every part before touching it. Failure to do so could result in serious injury or death.**

- (3) Release latches and remove cover assembly.
- (4) Tag and remove cable W101-2 leads from TB7 (1).
- (5) Remove screws from TB8 (2) terminals 1,2, 3, 4, 8, 9, 10, 11, and 12.
- (6) Tag and remove leads (3) from TBS.
- (7) Remove two screws (4) two lockwashers (5), and four flatwashers (6) from suppression board (7).
- (8) Remove suppression board.

**b. Installation.**

- (1) Install suppression board (7) to bracket.
- (2) Install four flatwashers (6) two lockwashers (5), and two screws (4) securing suppression board to bracket.
- (3) Install junction harness leads (3) to TB8 (2) terminals 1, 2, 3, 4, 8, 9, 10, 11, and 12 and secure with screws.
- (4) Install cable W101-2 leads to TB7 (1).

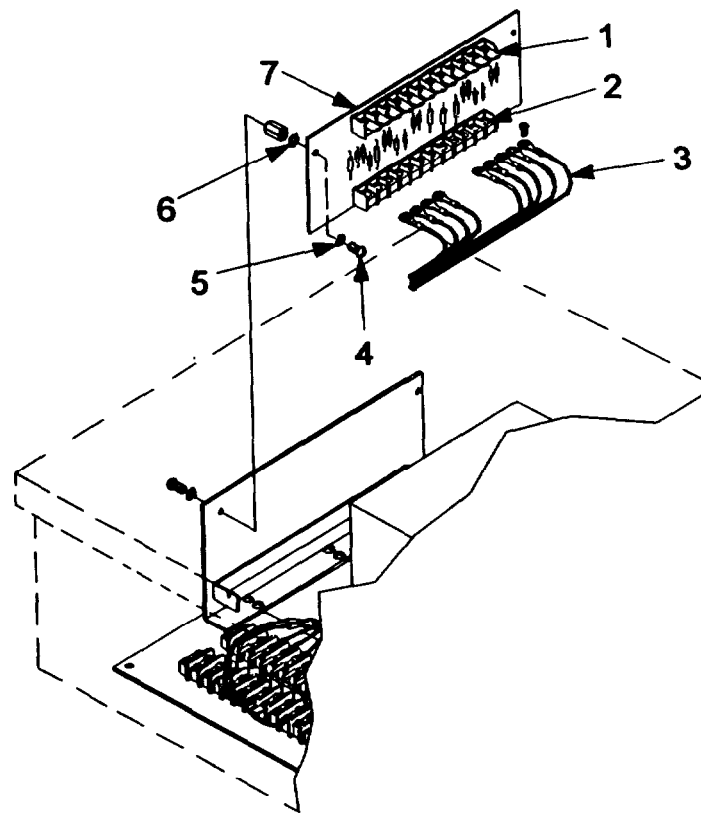

- (5) Install cover assembly and fasten latches.
- (6) Apply power to 240 vac incoming power line.
- (7) Set CB1 to the ON position.
- (8) Test in accordance with TM 9-6920-742-14-1.

**5-29 ICB/HIGH POWER CAPACITOR ASSEMBLY REPLACEMENT (M39014/02-1419).**

**INITIAL SETUP**

**Tools and Special Tools:**

General mechanic's automotive tool kit

**Personnel Required:**

2 persons (for safety purposes)

**Materials/Parts:**

Capacitor assembly (M39014/02-1419)

**References:**

TM 9-6920-742-14-1

**a. Removal.**

- (1) Set CB1 to the OFF position.
- (2) Remove power from 240 vac incoming power line.

**WARNING**



When working inside the equipment after power has been turned off, always ground every part before touching it. Failure to do so could result in serious injury or death.

- (3) Release latches and remove cover assembly.
- (4) Remove screws (1) and lockwashers (2) from TB2 terminals 5 and 6.

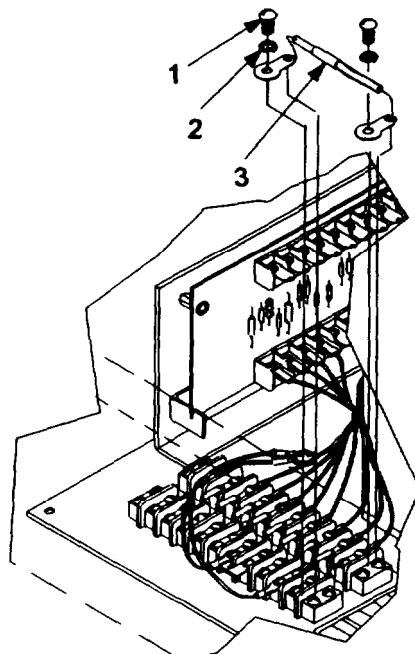

- (5) Remove resistors from TB1 terminals 5 and 6.
- (6) Remove capacitor assembly (3).

**b. Installation.**

- (1) Install capacitor assembly (3) to TB2 with + to terminal 5 and - to terminal 6.
- (2) Install resistors to TB2 terminals 5 and 6 and secure with screws (1) and lockwashers (2).
- (3) Install cover assembly and fasten latches,
- (4) Apply power to 240 vac incoming power line.
- (5) Set CB1 to the ON position.
- (6) Test in accordance with TM 9-6920-742-14-1.

**5-30 ICB/HIGH POWER RECTIFIER BRACKET ASSEMBLY REPLACEMENT (9353898-1).**

**INITIAL SETUP**

**Tools and Special Tools:**

General mechanic's automotive tool kit

**Personnel Required:**

2 persons (for safety purposes)

**Materials/Parts:**

Rectifier bracket assem. (9353898-1)

**References:**

TM 9-6920-742-14-1

**a. Removal.**

- (1) Set CB1 to the OFF position.
- (2) Remove power from 240 vac incoming power line.

**WARNING**



**When working inside the equipment after power has been turned off, always ground every part before touching it. Failure to do so could result in serious injury or death.**

- (3) Release latches and remove cover assembly.
- (4) Remove screws (1) and lockwashers (2) from TB3 (3) terminals 3, 5, 6, and 7.
- (5) Remove rectifier assembly leads (4) from TB3.

**5-30 ICB/HIGH POWER RECTIFIER BRACKET ASSEMBLY REPLACEMENT (935389-1)  
(CONTINUED).**

- (6) Remove two screws (5) and flatwashers (6) and remove rectifier bracket assembly (7) from mounting plate.

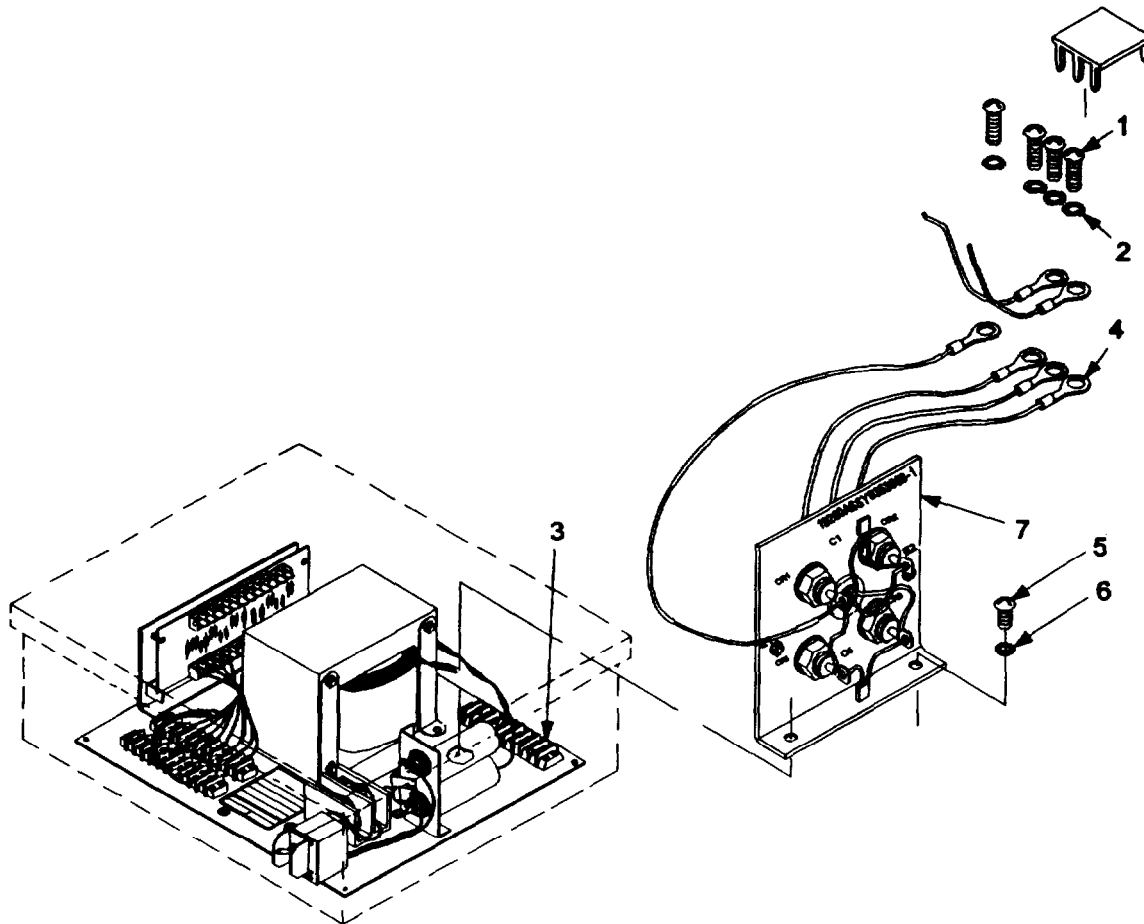

**b. Installation.**

- (1) Install rectifier bracket assembly (7) to mounting plate and secure with two screws (5) and flatwashers (6).
- (2) Install rectifier assembly leads (4) to TB3 (3) terminals 3, 5, 6, and 7 and secure with screws (1) and lockwashers (2).
- (3) Install cover assembly and fasten latches.
- (4) Apply power to 240 vac incoming power line.
- (5) Set CB1 to the ON position.
- (6) Test in accordance with TM 9-6920-742-14-1.

**5-31 ICB/HIGH POWER TRANSFORMER ASSEMBLY REPLACEMENT (9353821).****INITIAL SETUP****Tools and Special Tools:**

General mechanic's automotive tool kit

**Personnel Required:**

2 persons (for safety purposes)

**Materials/Parts:**

Transformer assembly (9353821)

**References:**

TM 9-6920-742-14-1

**a. Removal.**

- (1) Set CB1 to the OFF position.
- (2) Remove power from 240 vac incoming power line.

**WARNING**

When working inside the equipment after power has been turned off, always ground every part before touching it. Failure to do so could result in serious injury or death.

- (3) Release latches and remove cover assembly.
- (4) Remove two nuts (1) and lockwashers (2) from output ends of EMI filters (FL1 and FL2).
- (5) Tag and remove two transformer leads (3) from FL1 and FL2.
- (6) Remove screws and lockwashers from TB3 (4) terminals 6 and 7.
- (7) Tag and remove transformer leads (5) from TB3.
- (8) Remove screw (6) and lockwasher (7) from E5.
- (9) Tag and remove transformer ground lead (8) from E5.

**WARNING**

Mounting plate assembly contains transformer which weighs approximately 40 pounds (18.16 kilograms). Use proper lifting procedures when removing or installing. Failure to do so could result in serious bodily injury.

- (10) Remove two transformer mounting screws (9) and flatwashers (10).

5-31 ICB/HIGH POWER TRANSFORMER ASSEMBLY REPLACEMENT (9353821) (CONTINUED).

(11) Remove transformer assembly (11) from mounting plate.

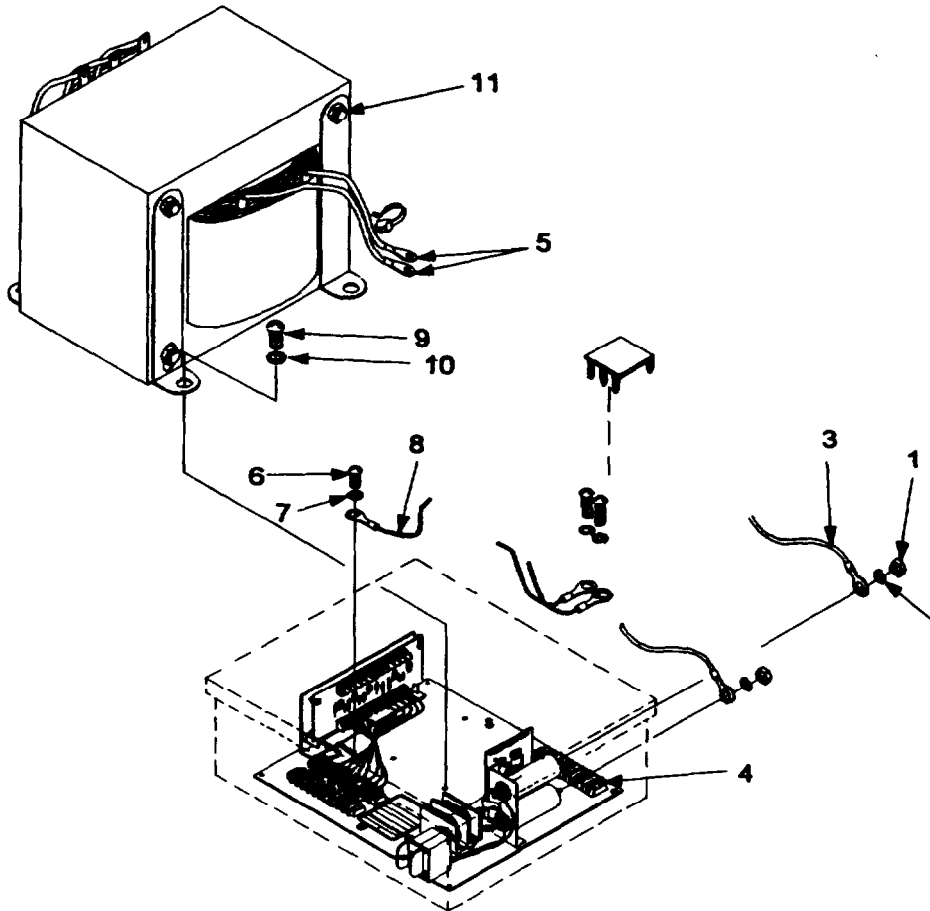

b. Installation.

**WARNING**



Mounting plate assembly contains transformer which weighs approximately 40 pounds (18.16 kilograms). Use proper lifting procedures when removing or installing. Failure to do so could result in serious bodily injury.

- (1) Install transformer assembly (11) to mounting plate.
- (2) Install two screws (9) and flatwashers (10) securing transformer assembly to mounting plate.



- (3) Install transformer ground lead (8) to E5 and secure with screw (6) and lockwasher (7).

**WARNING**



Ensure transformer primary wires are attached to FL1 and FL2 and not TB3. Failure to do so could result in death or serious injury.

- (4) Install transformer secondary. leads (5) to TB3 (4) terminals 6 and 7 and secure with screws and lockwashers.
- (5) Install two transformer primary leads (3) to output ends of FL1 and FL2 and secure with lockwashers (2) and nuts (1).
- (6) Install cover assembly and fasten latches.
- (7) Apply power to 240 vac incoming power line.
- (8) Set CB1 to the ON position.
- (9) Test in accordance with TM 9-6920-742-14-1.

**5-32 ICB/HIGH POWER TERMINAL LUG REPLACEMENT (MS25036-156).**

**INITIAL SETUP**

**Tools and Special Tools:**

- General mechanic's automotive tool kit
- Wire strippers
- Crimping tool

**Personnel Required:**

2 persons (for safety purposes)

**References:**

TM 9-6920-742-14-1

**Materials/Parts:**

- Terminal lug (MS25036-156)

- a. Set CB1 to the OFF position.
- b. Remove power from 240 vac incoming power line.

**WARNING**



When working inside the equipment after power has been turned off, always ground every part before touching it. Failure to do so could result in serious injury or death.

**5-32 ICB/HIGH POWER TERMINAL UG REPLACEMENT (MS25036-156) (CONTINUED).**

- c. Release latches and remove cover assembly.
- d. Remove two nuts (1), and lockwashers (2) from output ends of EMI filters (FL1 and FL2).
- e. Tag and remove transformer leads (3) from FL1 and FL2.
- f. Remove two screws and lockwashers from TB3 (4) terminals 6 and 7.

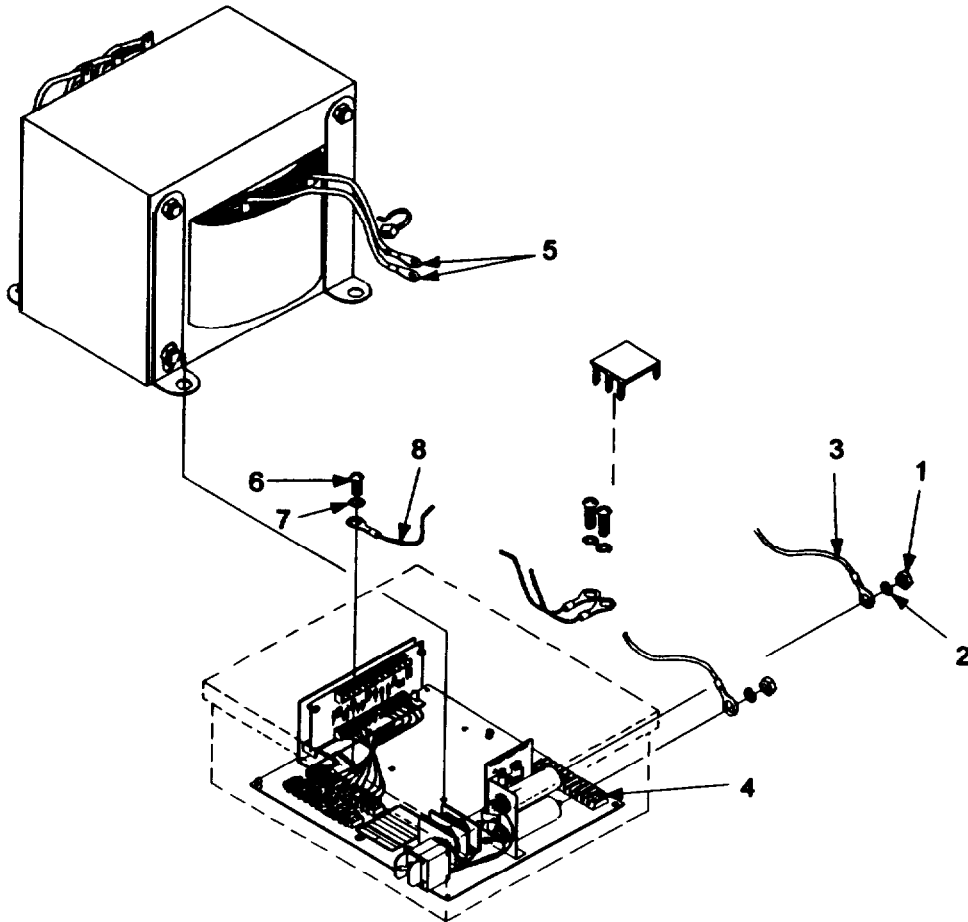

- g. Tag and remove transformer leads (5) from TB3.
- h. Remove screw (6) and lockwasher (7) from E5.
- i. Tag and remove transformer ground lead (8) from E5.
- j. Cutter terminal lug from lead.
- k. Strip insulation back 1/4 inch (.635 cm) from end of lead.
- l. Install new terminal lug and crimp tight.

- m. Repeat for other transformer leads.
- n. Install transformer ground to E5 and secure with screw and lockwasher.
- o. Install two transformer primary leads to output ends of FL1 and FL2.

**WARNING**

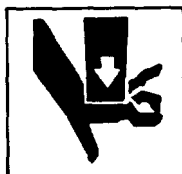

Ensure transformer primary wires are attached to FL1 and FL2 and not TB3. Failure to do so could result in death or serious injury.

- p. Install lockwashers and nuts to FL1 and FL2.
- q. Install two transformer secondary leads to TB3 terminals 6 and 7 and secure with two screws and lockwashers.
- r. Install cover assembly and fasten latches.
- s. Apply power to 240 vac incoming power line.
- t. Set CB1 to the ON position.
- u. Test in accordance with TM 9-6920-742-14-1.

### **5-33 ASSEMBLY OF ICB/HIGH POWER CIRCUIT BREAKER ASSEMBLY (CB1) (9353916).**

#### **INITIAL SETUP**

##### **Tools and Special Tools:**

General mechanic's automotive tool kit  
Heat gun  
Soldering and desoldering set  
Wire strippers  
Crimping tool

##### **Materials/Parts:**

Circuit breaker (9353916)  
Insulation sleeving (M23053/5-106-0)  
Terminal lug (MS25036-153)  
Wire (M16878/4BKE0)  
Solder (item 11, appendix D)

- a. Cut four wires to lengths of 11.00 inches (27.94 cm), 11.00 inches (27.94 cm), 13.15 inches (33.40 cm), and 14.25 inches (36.12 cm).
- b. Strip back insulation on all wire ends 1/4 inch (.635 cm).
- c. Install terminal lug (1) to one end of each wire and crimp tight.
- d. Slide insulation sleeving (2) over ends of each wire.
- e. Install two 11.00-inch (27.94 cm) leads to circuit breaker load terminals (3).

**5-33 ASSEMBLY OF ICB/HIGH POWER CIRCUIT BREAKER ASSEMBLY (CB1) (9353916)  
(CONTINUED).**

- f. Solder leads to load terminals.
- g. Install two remaining leads to circuit breaker line terminals (4).
- h. Solder leads to line terminals.
- i. Slide insulation sleeving over all connections, apply heat and shrink tight.

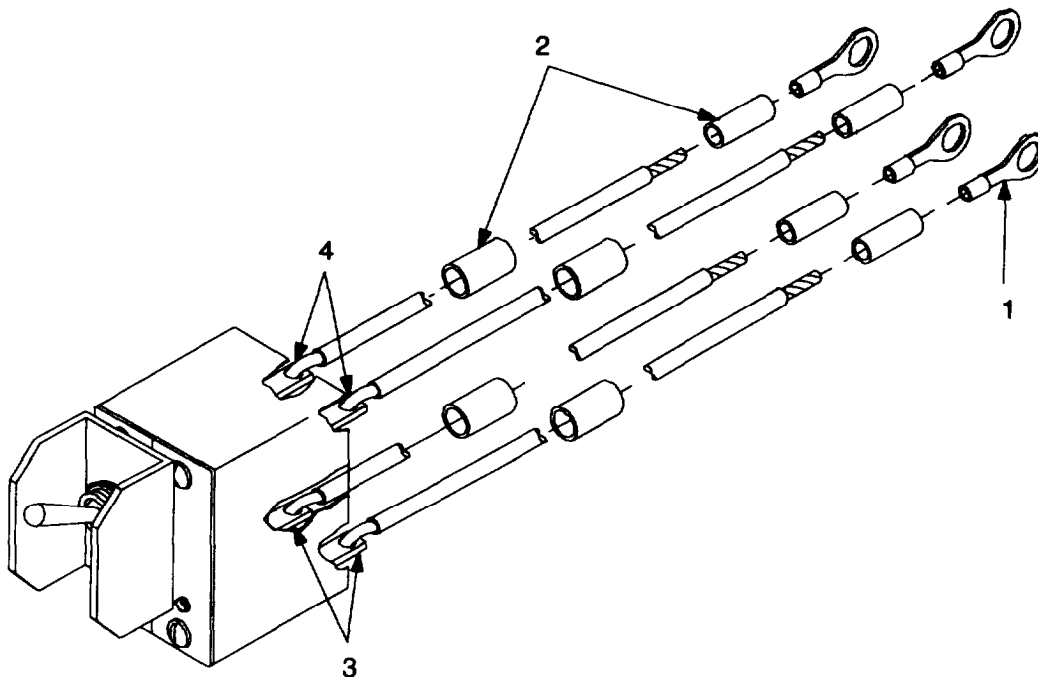

**5-34 JUMPER ASSEMBLY REPLACEMENT (9387197-1).**

**INITIAL SETUP**

**Tools and Special Tools:**

General mechanic's automotive tool kit

**Personnel Required:**

2 persons (for safety purposes)

**Materials/Parts:**

Jumper assembly (9387197-1)  
Tiedown straps (MS3368-1-9B)

**References:**

TM 9-6920-742-14-1

**a. Removal.**

- (1) Set CB1 to the OFF position.
- (2) Remove power from 240 vac incoming power line.

**WARNING**

When working inside the equipment after power has been turned off, always ground every part before touching it. Failure to do so could result in serious injury or death.

- (3) Release latches and remove cover assembly.
- (4) Remove screw (1) and lockwasher (2) from E5.
- (5) Remove screw (3) and lockwasher (4) from TB1 terminal 9 (5).
- (6) Cut tiedown straps (6) and remove jumper assembly (7).

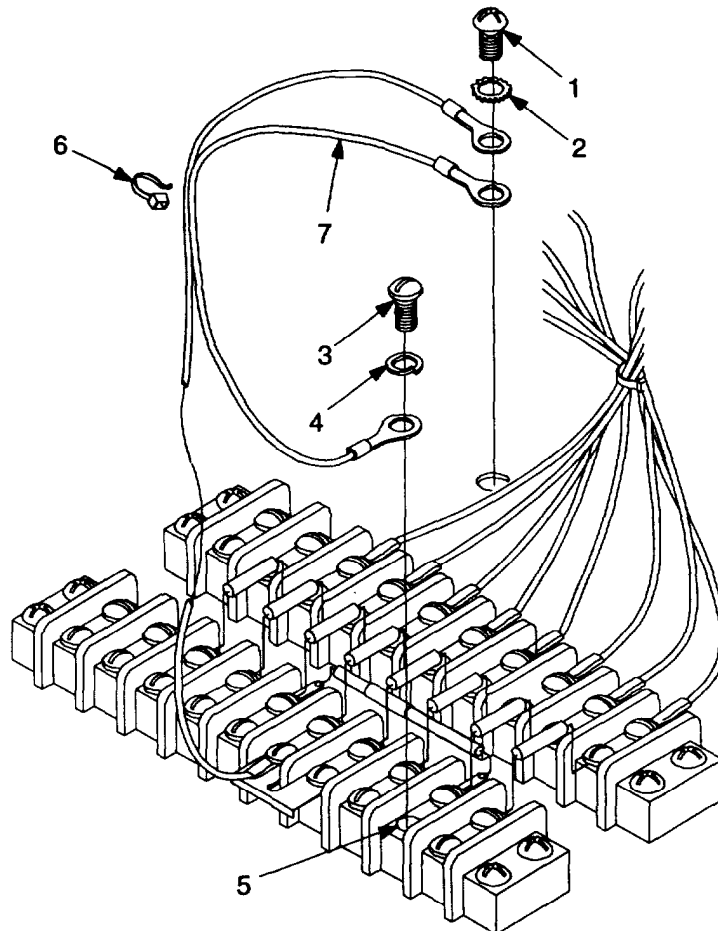

**5-34 ICB/HIGH POWER JUMPER ASSEMBLY REPLACEMENT (9387197-1) (CONTINUED).**

**b. Installation.**

- (1) Install jumper assembly (7) to E5 and secure with screw (1) and lo&washer (2).
- (2) Install jumper assembly to TB1 terminal 9 (5) and secure with screw (3) and lockwasher (4).
- (3) Install tiedown straps (6) as necessary.
- (4) Install cover assembly and fasten latches.
- (5) Apply power to 240 vac incoming power line.
- (6) Set CB1 to the ON position.
- (7) Test in accordance with TM 9-6920-742-14-1.

**5-35 ASSEMBLY OF ICB/HIGH POWER JUMPER ASSEMBLY (9387197-1).**

**INITIAL SETUP**

**Tools and Special Tools:**

General mechanic's automotive tool kit  
Wire strippers  
Crimping tool

**Materials/Par&s:**

Terminal lug (MS25036-101)  
Terminal lug (MS25036-149)  
Wire (M16876/4BHEO)

---

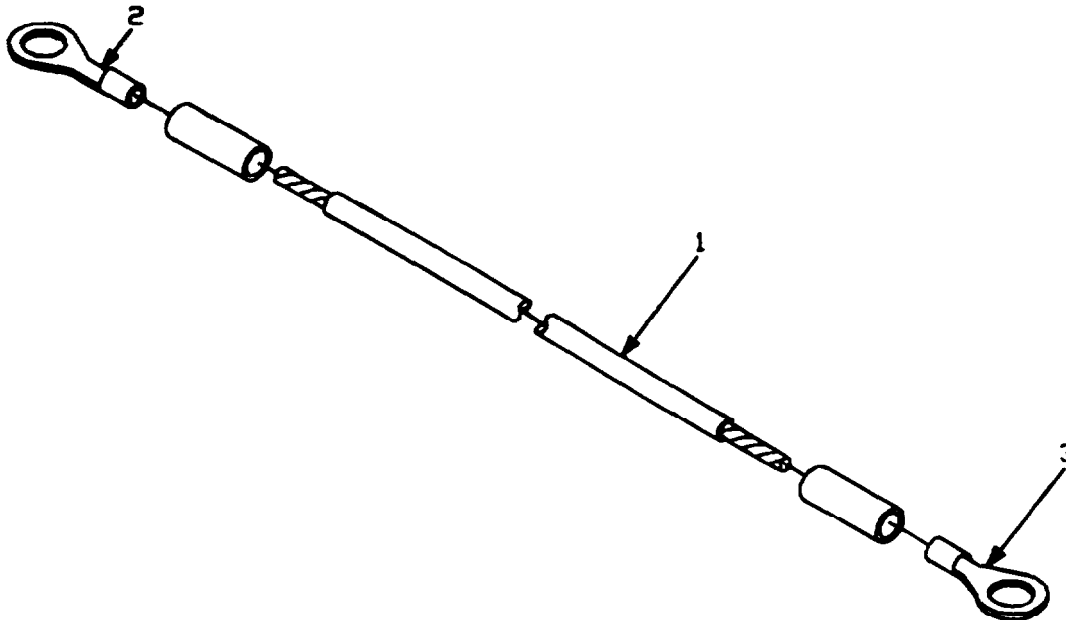

- (1) Cut wire (1) to 7.8-inch (19.81 cm) length.
- (2) Strip back insulation 1/4 inch (.635 cm) on both ends.
- (3) Install terminal lug (2) (MS25036-101) to one wire end and crimp tight.
- (4) Install terminal lug (3) (MS25036-149) to other end of wire and crimp tight.

**5-36 ICB/HIGH POWER JUMPER ASSEMBLY REPLACEMENT (9387197-2).**

**INITIAL SETUP**

**Tools and Special Tools:**

General mechanic's automotive tool kit

**Personnel Required:**

2 persons (for safety purposes)

**Materials/Parts:**

Jumper assembly (9387197-2)

Tiedown strap (MS3368-1-9B)

**References:**

TM 9-6920-742-14-1

**a. Removal.**

- (1) Set CB1 to the OFF position.
- (2) Remove power from 240 vac incoming power line.

**WARNING**



**When working inside the equipment after power has been turned off, always ground every part before touching it. Failure to do so could result in serious injury or death.**

- (3) Release latches and remove cover assembly.
- (4) Remove screw (1) and lo&washer (2) from E5.
- (5) Remove screw (3) and lockwasher (4) from TB1 terminal 6 (5).
- (6) Cut tiedown straps (6) and remove jumper assembly (7).

**b. Installation.**

- (1) Install jumper assembly (7) to E5 and secure with screw (1) and lockwasher (2).
- (2) Install jumper assembly to TB1 terminal 6 (5) and secure with screw (3) and lockwasher (4).
- (3) Install tiedown straps (6) as necessary.

5-36 ICB/HIGH POWER JUMPER ASSEMBLY REPLACEMENT (9387197-2) (CONTINUED).

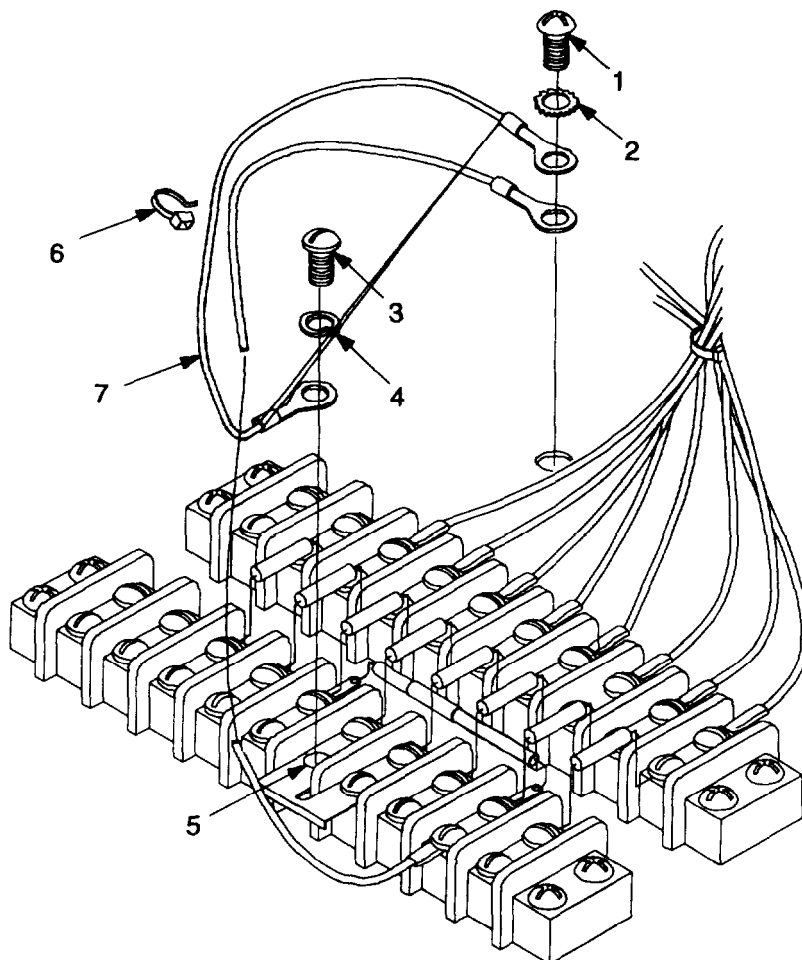

- (4) Install cover assembly and fasten latches.
- (5) Apply power to 240 vac incoming power line.
- (6) Set CB1 to the ON position.
- (7) Test in accordance with TM 9-6920-742-14-1.



**5-37 ASSEMBLY OF ICB/HIGH POWER JUMPER ASSEMBLY (9387197-2).****INITIAL SETUP****Tools and Special Tools:**

General mechanic's automotive tool kit  
Wire strippers  
Crimping tool

**Materials/Parts:**

Terminal lug (MS25036-101)  
Terminal lug (MS25036-149)  
Wire (M16878/4BHEO)

---

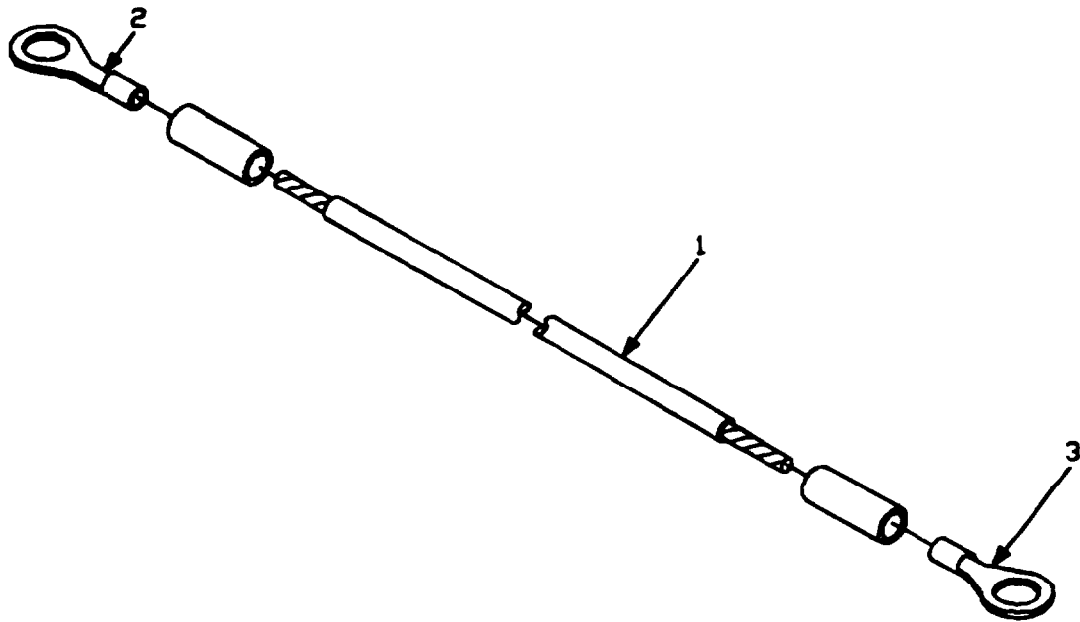

- a. Cut wire (1) to 8.8-inch (22.35 cm) length.
- b. Strip back insulation 1/4 inch (.635 cm) on both ends.
- c. Install terminal lug (2) (MS25036-101) to one wire end and crimp tight.
- d. Install terminal lug (3) (MS25036-149) to other end of wire and crimp tight.

**5-38 ICB/HIGH POWER CONNECTOR P3 REPLACEMENT (MS3476W20-39P).**

**INITIAL SETUP**

**Tools and Special Tools:**

General mechanic's automotive tool kit  
Heat gun  
Soldering and desoldering set  
Wire strippers  
Crimping tool

**Materials/Parts(Continued):**

Connector (9353932)  
Solder (item 11, appendix D)  
Tape (item 13, appendix D)  
Sealing compound (item 8, appendix D)

**Materials/Parts:**

Connector (MS3476W20-39P)  
Insulation sleeving (M23053/5-310-0)  
Wire (M22759/11-20-9)

**Personnel Required:**

2 persons (for safety purposes)

**References:**

TM 9-6920-742-14-1

- a. Set CB1 to the OFF position.
- b. Remove power from 240 vac incoming power line.

**WARNING**



When working inside the equipment after power has been turned off, always ground every part before touching it. Failure to do so could result in serious injury or death.

- c. Release latches and remove cover assembly.
- d. Remove leads from TB7 terminals 3, 4, 6, 7, 8, 9, 10, 11, and 12.
- e. Remove connector P3 from J2 of the IMTC and remove cable assembly.
- f. Remove two screws (1) from strain relief (2) on backshell (3) attached to connector P3 (4).
- g. Remove connector P3 from backshell and expose wiring.
- h. Cut wiring as close as possible to connector P3 and remove.

**NOTE**

**If cable will be shortened to less than a serviceable length by replacing connector, cable must be replaced.**

- i. Strip outer insulation on cable 2-inches (5.08 cm) from end.
- j. Tape end of cable insulation and position backshell over cable.
- k. Fan overall shield (5) and twist together.

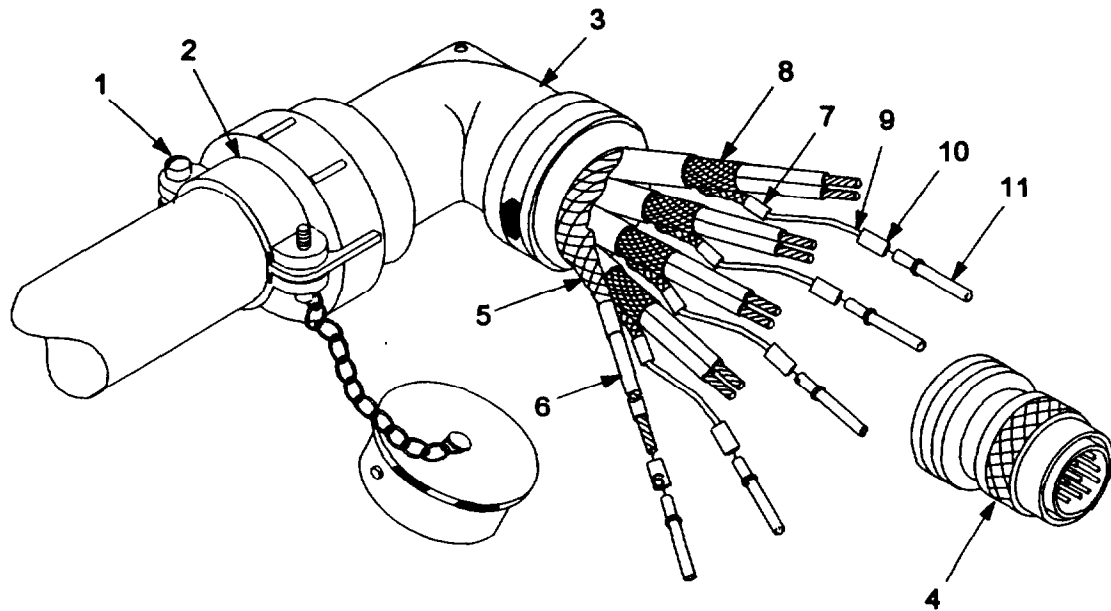

- l. Tin end of overall shield approximately 1/2 inch (1.27 cm).
- m. Strip insulation back 1/4 inch (.653 cm) from end of piece of 20 AWG wire (6) and solder to tinned shield.
- n. Install connector (7) over an inner shield (8).
- o. Strip insulation back 1/4 inch (.653 cm) from end of piece of 20 AWG wire (9).
- p. Insert stripped end of 20 AWG wire into crimp connector and crimp tight.
- q. Using the same procedure, crimp 20 AWG wires to remaining three inner shields.
- r. Remove tape from end of cable insulation.
- s. Strip insulation back 1/4 inch (.653 cm) from ends of 16 cable leads.
- t. Slide insulation sleeving (10) over ends of cable leads.
- u. Attach pins (11) to cable leads and solder in place.
- v. Slide insulation sleeving over pin connections.
- w. Apply heat and shrink insulation sleeving over connections.
- x. Using the following table, insert pins into connector P3.

5-38 ICB/HIGH POWER CONNECTOR P3 REPLACEMENT (MS3476W20-39P) (CONTINUED).

PIN	WIRE COLOR
A	blue/blk
B	grn/blk
C	orn/blk
c	red/blk
d	gray/blk
X	c and d pair inner shield
e	blk
f	gray
Y	e and f pair inner shield
i	red
j	grn
Z	i and j pair inner shield
h	blue
g	orn
b	h and g pair inner shield
L	overall shield

- y. Apply sealing compound to threads of connector P3.
- z. Install connector P3 to backshell.
- aa. Install and tighten two screws on strain relief on backshell.
- ab. Install cable assembly leads to TB7 terminals 3, 4, 6, 7,8, 9, 10, 11, and 12.
- ac. Install connector P3 to J2 of IMTC.
- ad. Install cover assembly and fasten latches..
- ae. Apply power to 240 vac incoming power line.
- af. Set CB1 to the ON position.
- ag. Test in accordance with TM 9-6920-742-14-1

**5-39 ICB/HIGH POWER TERMINAL LUG REPLACEMENT (9354176).**

**INITIAL SETUP**

**Tools and Special Tools:**

General mechanic's automotive tool kit  
 Wire strippers  
 Crimping tool

**Materials/Parts:**

Terminal lug (9354176)

**Personnel Required:**

2 persons (for safety purposes)

**References:**

TM 9-6920-742-14-1

- a. Set CB1 to the OFF position.
- b. Remove power from 240 vac incoming power line.

**WARNING**



When working inside the equipment after power has been turned off, always ground every part before touching it. Failure to do so could result in serious Injury or death.

- c. Release latches and remove cover assembly.

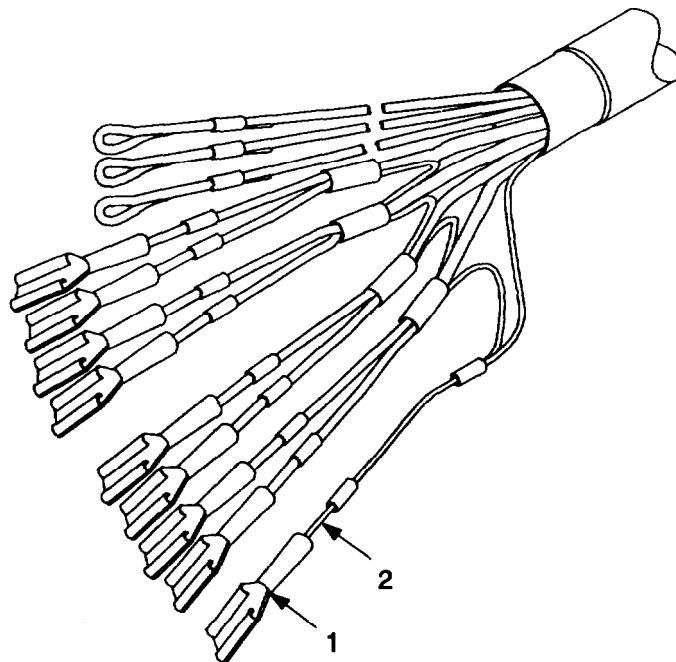

**5-39 ICB/HIGH POWER TERMINAL LUG REPLACEMENT (9354176) (CONTINUED).**

- d. Remove lead to be replaced from TB7 terminal.
- e. Cut terminal lug (1) from lead (2) as close to terminal lug as possible.
- f. Strip back insulation 1/4 inch (.653 cm) from end of lead.
- g. Install new terminal lug and crimp tight.
- h. Install lead to TB7 terminal.
- i. Repeat procedure for other terminal lugs being replaced.
- j. Install cover assembly and fasten latches.
- k. Apply power to 240 vac incoming power line.
- l. Set CB1 to the ON position.
- m. Test in accordance with TM 9-6920-742-14-1.

**5-40 ICB/HIGH POWER CONNECTOR REPLACEMENT (9353932)**

**INITIAL SETUP**

**Tools and Special Tools:**

General mechanic's automotive tool kit  
Crimping tool

**Materials/Parts:**

Connector (9353932)

**Personnel Required:**

2 persons (for safety purposes)

**References:**

TM 9-6920-742-14-1

- 
- a. Set CB1 to the OFF position.
  - b. Remove power from 240 vac incoming power line.

**WARNING**



When working inside the equipment after power has been turned off, always ground every part before touching it. Failure to do so could result in serious injury or death.

- c. Release latches and remove cover assembly.
- d. Remove leads from TB7 terminals 3, 4, 6, 7, 8, 9, 10, 11, and 12.

- e. Remove connector P3 from J2 of IMTC and remove cable assembly.
- f. Pry connector (1) from TB7-12 and TB7-11 pair shield and 20 AWG wire (2).

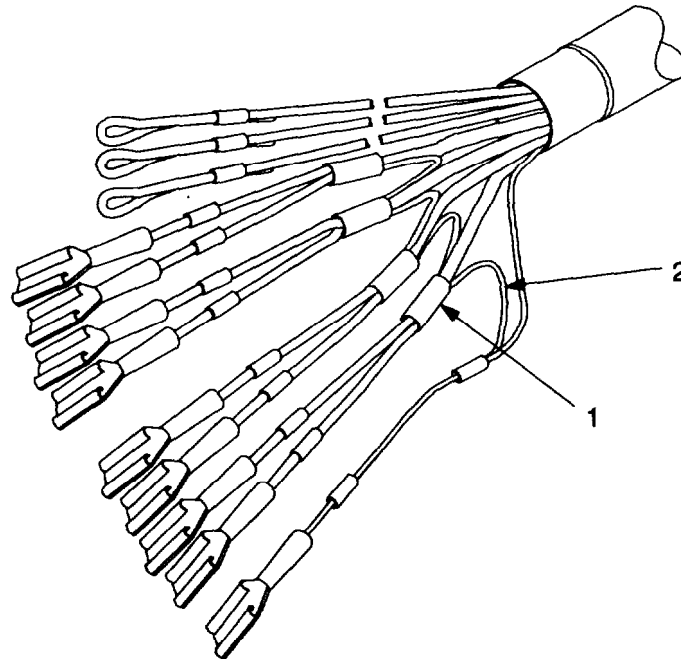

- g. Install new connector over inner shield and 20 AWG wire.
- h. Crimp tight.
- i. Repeat process for TB7-10 and TB7-5 pair shield, TB7-3 and TB7-8 pair shield, and TB7-6 and TB7-7 pair shield.
- j. Install cable assembly leads to TB7 terminals 3, 4, 6,7, 8, 9, 10, 11, and 12.
- k. Install connector P3 to J2 of IMTC.
- l. Install cover assembly and fasten latches.
- m. Apply power to 240 vac incoming power line.
- n. Set CB1 to the ON position.
- o. Test in accordance with TM 9-6920-742-14-1.

5-41 ICB/HIGH POWER CONNECTOR P2 REPLACEMENT (MS3126E16-14s).

**INITIAL SETUP**

**Tools and Special Tools:**

General mechanic's automotive tool kit  
Heat gunSoldering and desoldering set  
Wire strippers  
Crimping tool

**Materials/Parts:**

Connector (MS3126E16-14s)  
Insulation sleeving (M23053/5-308-0)  
Wire (M22759/11-20-9)

**Materials/Parts (Continued):**

Solder (item II, appendix D)  
Tape (item 13, appendix D)  
Sealing compound (item 8, appendix D)

**Personnel Required:**

2 persons (for safety purposes)

**References:**

TM 9-6920-742-14-1

---

- a. Set CB1 to the OFF position.
- b. Remove power from 240 vac incoming power line.

**WARNING**

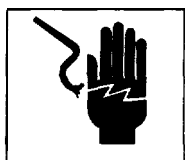

**When working inside the equipment after power has been turned off, always ground every part before touching it. Failure to do so could result in serious injury or death.**

- c. Release latches and remove cover assembly.
- d. Remove screws and lockwashers from TB3 terminals 2, 3, 4, 5, 8, 9, and E4.
- e. Remove leads from TB3 and E4.
- f. Remove connector P2 from J1 of IMTC and remove cable assembly.
- g. Remove two screws (1) from strain relief (2) on backshell (3) attached to connector P2 (4).
- h. Remove connector P2 and expose wiring.
- i. Cut wiring as close to connector P2 as possible and remove.

**NOTE**

**If cable will be shortened to less than a serviceable length by replacing connector, cable must be replaced.**

- j. Strip outer insulation on cable 2 inches (5.08 cm) from end.
- k. Tape end of cable insulation and position backshell over cable.



- l. Fan overall shield (5) and twist together.
- m. Tin end of overall shield approximately 1/2 inch (1.27 cm).
- n. Strip insulation back 1/4 inch (.653 cm) from end of piece of 20 AWG wire (6) and solder to tinned shield.

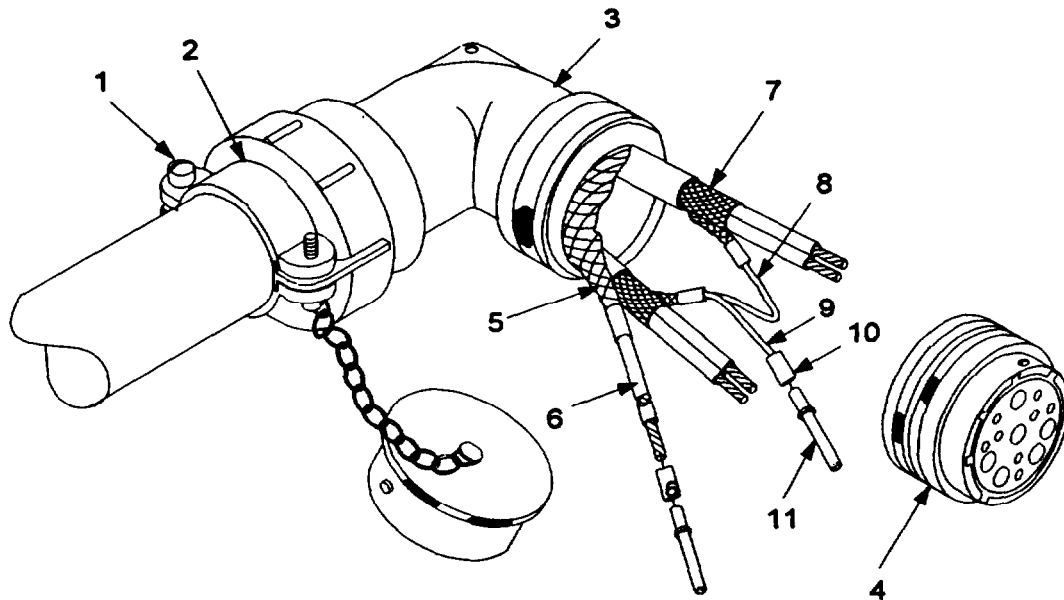

- o. Fan D and G pair inner shield (7) and twist together.
- p. Fan E and H pair inner shield and twist together.
- q. Tin ends of inner shields approximately 1/2 inch (1.27 cm).
- r. Strip insulation back 1/4 inch (.653 cm) from ends of piece of 20 AWG wire (8).
- s. Connect inner shields by soldering stripped ends of 20 AWG wire to tinned shields.
- t. Strip insulation back 1/4 inch (.653 cm) from end of piece of 20 AWG wire (9).
- u. Solder stripped end of 20 AWG wire to tinned shield of E and H pair.
- v. Remove tape from end of cable insulation.
- w. Strip insulation back 1/4 inch (.653 cm) from ends of eight cable leads.
- x. Slide insulation sleeving (10) over ends of cable leads.
- y. Attach pins (11) to cable leads and solder in place.
- z. Slide insulation sleeving over pin connections.

5-41 ICB/HIGH POWER CONNECTOR P2 REPLACEMENT (MS3126E16-14S) (CONTINUED).

- aa. Apply heat and shrink insulation sleeving over connections.
- ab. Using the following table, insert pins into connector P2.

PIN	WIRE COLOR
D	orn
G	blue
E	grn
H	red
K	D and G pair and E and H pair shield
A	blk
P	gray
F	overall shield

- ac. Apply locking compound to threads of connector P2.
- ad. Install connector P2 onto backshell.
- ae. Install and tighten two screws in strain relief on backshell.
- af. Install cable leads to TB3 terminals 2, 3, 4, 5,8, 9, and E4 and secure with screws and lo&washers.
- ag. Install connector P2 to J1 OF IMTC.
- ah. Install cover assembly and fasten latches.
- ai. Apply power to 240 vac incoming power line.
- aj. Set CB1 to the ON position.
- ak. Test in accordance with TM 9-6920-742-14-1.

**5-42 ICB/HIGH POWER TERMINAL LUG REPLACEMENT (MS25036-156).****INITIAL SETUP****Tools and Special Tools:**

General mechanic's automotive tool kit  
Wire strippers  
Crimping tool

**Personnel Required:**

2 persons (for safety purposes)

**References:**

TM 9-6920-742-14-1

**Materials/Parts:**

Terminal lug (MS25036-156)

---

- a. Set CB1 to the OFF position.
- b. Remove power from 240 vac incoming power line.

**WARNING**

When working inside the equipment after power has been turned off, always ground every part before touching it. Failure to do so could result in serious injury or death.

- c. Release latches and remove cover assembly.

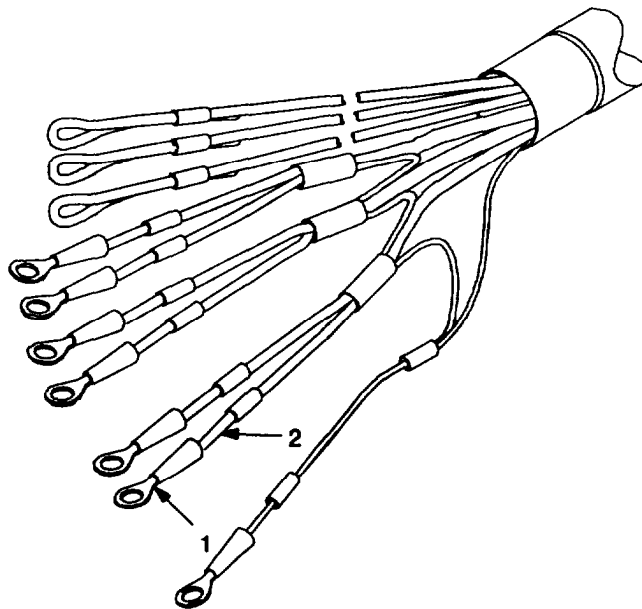

**5-42 ICB/HIGH POWER TERMINAL LUG REPLACEMENT (MS25036-156) (CONTINUED).**

- d. Remove screw and lockwasher from TB3 terminal lug to be replaced.
- e. Remove terminal lug from TB3.
- f. Cut terminal lug (1) from lead (2) as close to terminal lug as possible.
- g. Strip back insulation 1/4 inch (.653 cm) from end of lead.
- h. Install new terminal lug and crimp tight.
- i. Install lead to TB3 terminal and secure using screw and lockwasher.
- j. Repeat procedure for other terminal lugs being replaced.
- k. Install cover assembly and fasten latches.
- l. Apply power to 240 vac incoming power line.
- m. Set CB1 to the ON position.
- n. Test in accordance with TM 9-6920-742-14-1.

**5-43 ICB/HIGH POWER TERMINAL LUG REPLACEMENT (MS25036-149).**

**INITIAL SETUP**

**Tools and Special Tools:**

General mechanic's automotive tool kit  
Wire strippers  
Crimping tool

**Personnel Required:**

2 persons (for safety purposes)

**References:**

TM 9-6920-742-14-1

**Materials/Parts:**

Terminal lug (MS25036-149)

---

- a. Set CB1 to the OFF position.
- b. Remove power from 240 vac incoming power line.

**WARNING**



When working inside the equipment after power has been turned off, always ground every part before touching it. Failure to do so could result in serious injury or death.

- c. Release latches and remove cover assembly.
- d. Remove screw and lo&washer from E4 terminal.
- e. Remove lead from E4.
- f. Cut terminal lug (1) from lead (2) as close to terminal lug as possible.

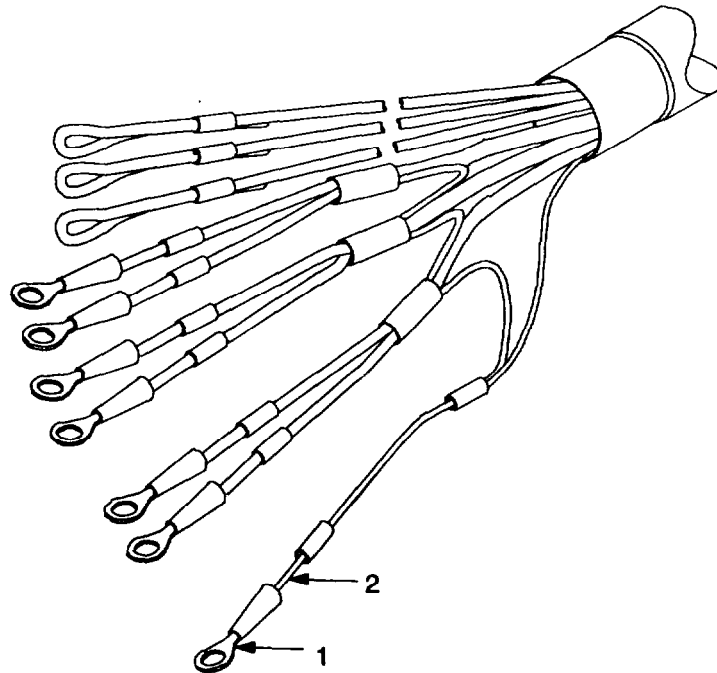

- g. Strip back insulation 1/4 inch (.653 cm) from end of lead.
- h. Install new terminal lug and crimp tight.
- i. Install lead to E4 terminal and secure using screw and new lockwasher.
- j. Install cover assembly and fasten latches.
- k. Apply power to 240 vac incoming power line.
- l. Set CB1 to the ON position.
- m. Test in accordance with TM 9-6920-742-14-1.

**5-44 ICB/LOW POWER REPLACEMENT (9341190).**

**INITIAL SETUP**

**Tools and Special Tools:**

General mechanic's automotive tool kit

**Personnel Required:**

2 persons (for safety purposes)

**Materials/Parts:**

ICB/Low Power (9341190)

Self-locking nuts (MS21083C04)

**References:**

TM 9-6920-742-14-1

---

**a. Removal.**

- (1) Set CB1 (1) to the OFF position.
- (2) Remove power from 240 vac incoming power line.

**WARNING**



**When working inside the equipment after power has been turned off, always ground every part before touching it. Failure to do so could result in serious injury or death.**

- (3) Release latches and remove cover assembly.
- (4) Loosen four screws (2), tag, and remove 240 vac incoming power leads from TB5 terminals 1 (3) and 2 (4), E7 (5), and E8 (6).
- (5) Remove screws and lockwashers from TB3 (7) terminals 2,3, 4,5, 8, 9, and chassis ground (8).
- (6) Tag and remove cable W1O2-1 (9) leads from TB3.
- (7) Remove screws and lockwashers from TB1 (10) terminals 3, 4, 5, 6, 7, 8, 9, and 10.
- (8) Tag and remove incoming data leads (11) from TB1.
- (9) Tag and remove cable W101-1 (12) leads from TB7 (13).
- (10) Remove nut (14), washer (15), and switch guard (16) from CB1.
- (11) Remove CB1 from housing assembly.
- (12) Remove screws (17), outlet cover (18), gasket (19), outlet screws (20) and outlet (21) from housing.

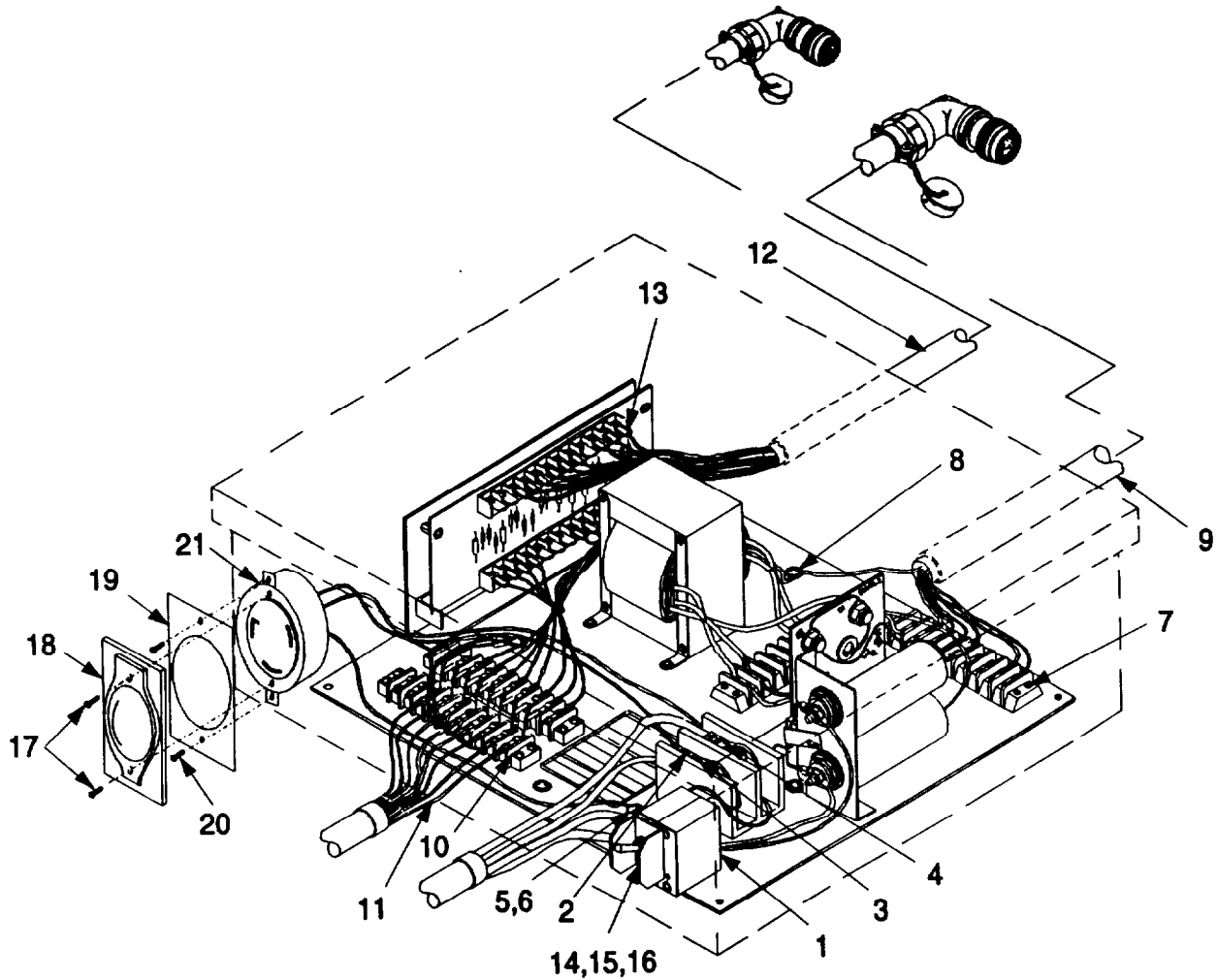

(13) Remove mounting hardware securing mounting plate to housing assembly.

(14) Remove mounting plate from housing assembly.

**b. Installation.**

(1) Ensure CB1 (1) is in the OFF position.

(2) Remove power from 240 vac incoming power line.

5-44 ICB/LOW POWER REPLACEMENT (9341190) (CONTINUED).

**WARNING**

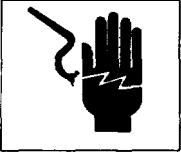

When working inside the equipment after power has been turned off, always ground every part before touching it. Failure to do so could result in serious injury or death.

- (3) Release latches and remove cover assembly.
- (4) Install mounting plate into housing assembly.
- (5) Install mounting hardware securing mounting plate to housing assembly.
- (6) Install CB1 (1) into housing assembly.
- (7) Install switch guard (16), washer (15), and nut (14) securing CB1 to housing assembly.
- (8) Install outlet (21) with screws (20) into housing assembly.
- (9) Install outlet cover gasket (19), and outlet cover (18), with screws (17) onto housing assembly.
- (10) Install cable W101-1 (12) leads to TB7 (13).

**NOTE**

**Ensure that jumper connection is in place between TB1 terminals 6 and 7 prior to installing screws and lockwashers**

- (11) Install incoming data lines (11) to TB1 (10) terminals 3, 4, 5, 6, 7, 8, 9, and 10 and secure with screws and lockwashers.
- (12) Install cable W102-1 (9) leads to TB3 (7) terminals 2, 3, 4, 5, 8, 9, and chassis ground (8) and secure with screws and new lockwashers.
- (13) Install incoming 240 vac power leads to TB5 terminals 1 (3) and 2 (4), E7 (5), and E8 (6) and secure with screws (2).
- (14) Install cover assembly and fasten latches.
- (15) Apply power to incoming 240 vac power line.
- (16) Set CB1 to the ON position.
- (17) Test in accordance with TM 9-6920-742-14-1.



**5-45 ICB/LOW POWER SUPPRESSION BOARD REPLACEMENT (9353854).**

**INITIAL SETUP**

**Tools and Special Tools:**

General mechanic's automotive tool kit

**Personnel Required:**

2 persons (for safety purposes)

**Materials/Parts:**

Suppression board (9353854)

**References:**

TM 9-6920-742-14-1

**a. Removal.**

- (1) Set CB1 to the OFF position.
- (2) Remove power from 240 vac incoming power line.

**WARNING**



When working inside the equipment after power has been turned off, always ground every part before touching it. Failure to do so could result in serious injury or death.

- (3) Release latches and remove cover assembly.
- (4) Tag and remove cable W101-1 leads from TB7 (1).

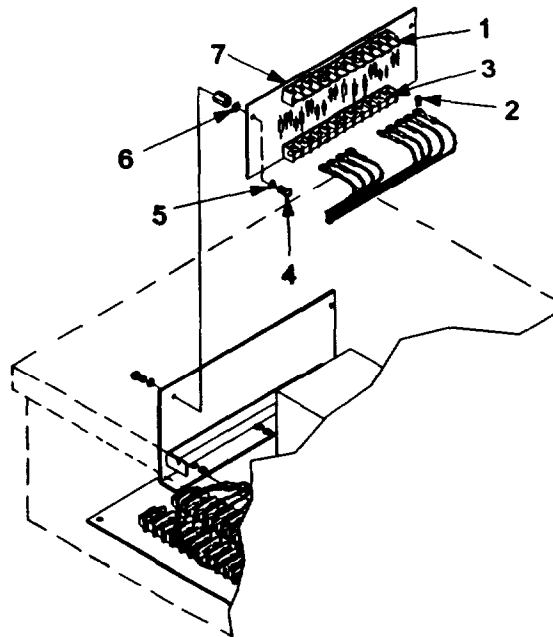

**5-45 ICB/LOW POWER SUPPRESSION BOARD REPLACEMENT (9353854) (CONTINUED).**

- (5) Remove screws (2) from TB8 (3) terminals 1, 2, 3, 4, 8, 9, 10, 11, and 12.
- (6) Tag and remove leads from TB8.
- (7) Remove two screws (4) two lockwashers (5) and four flatwashers (6) from suppression board (7).
- (8) Remove suppression board.

**b. Installation.**

- (1) Install suppression board (7) to bracket.
- (2) Install four flatwashers (6), two lockwashers (5), and two screws (4) securing suppression board to bracket.
- (3) Install lane junction harness leads to TB8 (3) terminals 1, 2, 3, 4, 8, 9, 10, 11, and 12 and secure with screws (2).
- (4) Install cable W101-1 leads to TB7 (1).
- (5) Install cover assembly and fasten latches.
- (6) Apply power to 240 vac incoming power line.
- (7) Set CB1 to the ON position.
- (8) Test in accordance with TM 9-6920-742-14-1.

**5-46 ICB/LOW POWER EMI FILTER REPLACEMENT (9353813).**

**INITIAL SETUP**

**Tools and Special Tools:**

General mechanic's automotive tool kit

**Personnel Required:**

2 persons (for safety purposes)

**Materials/Parts:**

EMI filter (9353813)

**References:**

TM 9-6920-742-14-1

---

**a. Removal.**

- (1) Set CB1 to the OFF position.
- (2) Remove power from 240 vac incoming power line.

<b>WARNING</b>
----------------



When working inside the equipment after power has been turned off, always ground every part before touching it. Failure to do so could result in serious injury or death.

- (3) Release latches and remove cover assembly.
- (4) Remove two nuts (1) and lockwashers (2) from input ends of EMI filters (3).
- (5) Tag and remove two CB1 load leads (4) and two gas tube arrestor leads (5) from EMI filters.
- (6) Remove two nuts (6) and lockwashers (7) from output ends of EMI filters.
- (7) Tag and remove two transformer leads (8) from EMI filters.
- (8) Remove nuts (9) and lockwashers (10) securing EMI filters to mounting bracket.
- (9) Remove EMI filters from bracket.

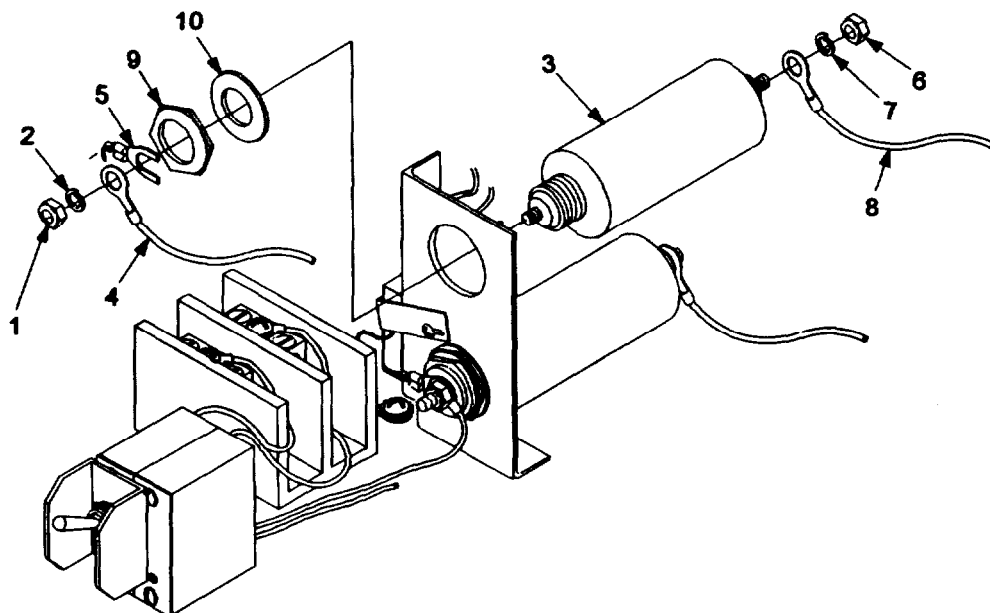

**b. Installation.**

- (1) Install EMI filters (3) to mounting bracket and secure with nuts (9) and lockwashers (10).
- (2) Install two transformer leads (8) to output ends of EMI filters and secure with two nuts (6) and lockwashers (7).

**5-46 ICB/LOW POWER EMI FILTER REPLACEMENT (9353813) (CONTINUED).**

- (3) Install two CB1 load leads (4) and two gas tube arrestor leads (5) to input ends of EMI filters and secure with two nuts (1) and lockwashers (2).
- (4) Install cover assembly and fasten latches.
- (5) Apply power to 240 vac incoming power line.
- (6) Set CB1 to the ON position.
- (7) Test in accordance with TM 9-6920-742-14-1.

**5-47 ICB/LOW POWER GAS TUBE ARRESTOR REPLACEMENT (9353905).**

**INITIAL SETUP**

**Tools and Special Tools:**

General mechanic's automotive tool kit

**Personnel Required:**

2 persons (for safety purposes)

**Materials/Parts:**

Gas tube arrestor (9353905)

**References:**

TM 9-6920-742-14-1

---

**a. Removal.**

- (1) Set CB1 to the OFF position.
- (2) Remove power from 240 vac incoming power line.

**WARNING**



**When working inside the equipment after power has been turned off, always ground every part before touching it. Failure to do so could result in serious injury or death.**

- (3) Release latches and remove cover assembly.
- (4) Loosen nuts (1) on input end of EMI filters (FL1 and FL2).
- (5) Remove gas tube arrestor leads (2) from FL1 and FL2.
- (6) Remove screw (3) and lockwasher (4) and remove gas tube arrestor ground lead (5) from E6.

- (7) Loosen screw (6) securing gas tube arrestor mounting bracket (7) and slide bracket aside.
- (8) Remove gas tube arrestor (8).

**b. Installation.**

- (1) Install gas tube arrestor (8) under mounting bracket.
- (2) Slide bracket (7) against gas tube arrestor and tighten screw (6).
- (3) Install gas tube arrestor ground lead (5) to E6 and secure with screw (3) and lockwasher (4).

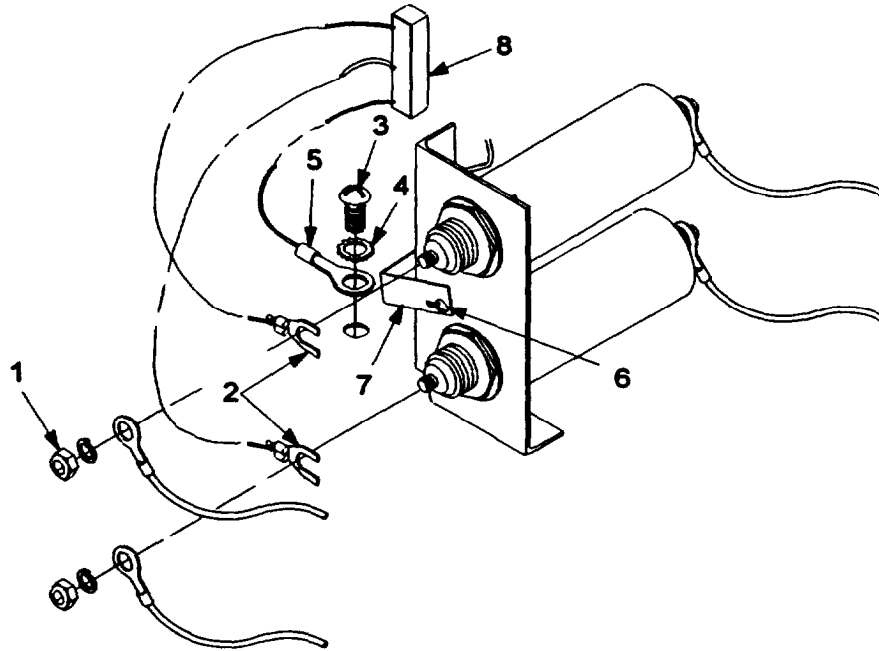

- (4) Install ends of gas tube arrestor leads (2) under lo&washers on input ends of FL1 and FL2 and tighten nuts (1) to secure.
- (5) Install cover assembly and fasten latches.
- (6) Apply power to 240 vac incoming power line.
- (7) Set CB1 to the ON position.
- (8) Test in accordance with TM 9-6926-742-14-1.

**5-48 ICB/LOW POWER CAPACITOR ASSEMBLY REPLACEMENT (M39014/02-1419).**

**INITIAL SETUP**

**Tools and Special Tools:**

General mechanic's automotive tool kit

**Personnel Required:**

2 persons (for safety purposes)

**Materials/Parts:**

Capacitor assembly (M39014/02-1419)

**References:**

TM 9-6920-742-14-1

**a. Removal.**

- (1) Set CB1 (1) to the OFF position.
- (2) Remove power from 240 vac incoming power line.

**WARNING**

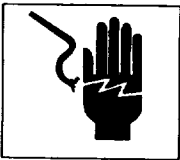

When working inside the equipment after power has been turned off, always ground every part before touching it. Failure to do so could result in serious injury or death.

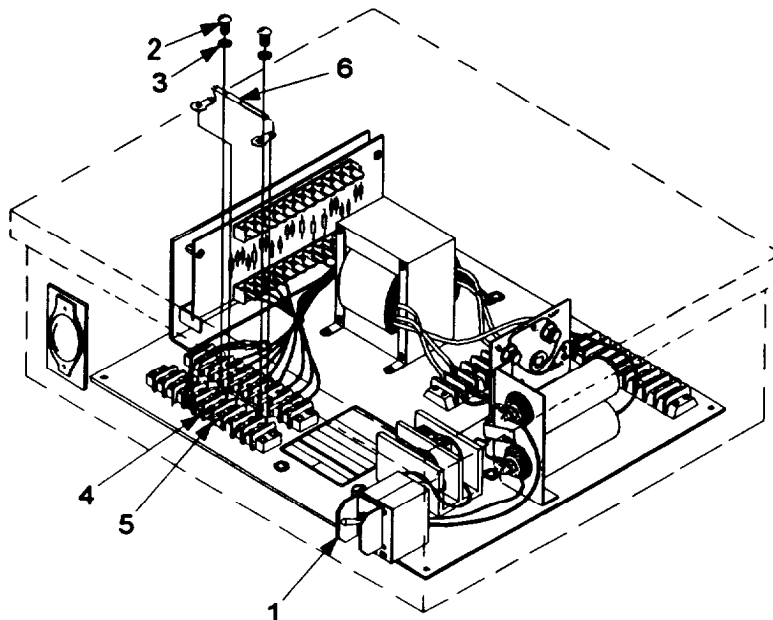

- (3) Release latches and remove cover assembly.
- (4) Remove screws (2) and lockwashers (3) from TB2 terminals 5 (4) and 6 (5).

- (5) Remove resistors from TB2 terminals 5 and 6.
- (6) Remove capacitor assembly (6).

**b. Installation.**

- (1) Install capacitor assembly (6) to TB2 with + to terminal 5 (4) and - to terminal 6 (5).
- (2) Install resistors to TB2 terminals 5 and 6 and secure with screws (2) and lockwashers (3).
- (3) Install cover assembly and fasten latches.
- (4) Apply power to 240 vac incoming power line.
- (5) Set CB1 (1) to the ON positions.
- (6) Test in accordance with TM 9-6920-742-14-1.

**5-49 ICB/LOW POWER RECTIFIER ASSEMBLY REPLACEMENT (9353898-2).**

**INITIAL SETUP**

**Tools and Special Tools:**

General mechanic's automotive tool kit

**Personnel Required:**

2 persons (for safety purposes)

**Materials/Parts:**

Rectifier assembly (9353898-2)

**References:**

TM 9-6920-742-14-1

**a. Removal.**

- (1) Set CB1 (1) to the OFF position.
- (2) Remove power from 240 vac incoming power line.

**WARNING**

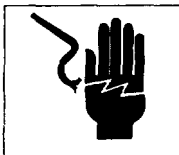

**When working inside the equipment after power has been turned off, always ground every part before touching it. Failure to do so could result in serious injury or death.**

- (3) Release latches and remove cover assembly.
- (4) Remove screw and lockwasher from TB3 (2) terminal 5.
- (5) Remove screws and lockwashers from TB4 (3) terminals 1, 2, 5, and 6.

5-49 ICB/LOW POWER RECTIFIER ASSEMBLY REPLACEMENT (9353898-2) (CONTINUED).

- (6) Tag and remove rectifier assembly leads from TB3 and TB4.
- (7) Remove two screws (4) and flatwashers (5) and remove rectifier bracket assembly (6) from mounting plate.

b. Installation.

- (1) Install rectifier bracket assembly (6) to mounting plate and secure with two screws (4) and flatwashers (5).
- (2) Install rectifier assembly lead to TB3 (2) terminal 5 and secure with screw and lockwasher.
- (3) Install rectifier assembly leads to TB4 (3) terminals 1,2,5, and 6 and secure with screws and lockwashers.
- (4) Install cover assembly and fasten latches.
- (5) Apply power to 240 vac incoming power line.
- (6) Set CB1 (1) to the ON position.
- (7) Test in accordance with TM 9-6920-742-14-1.

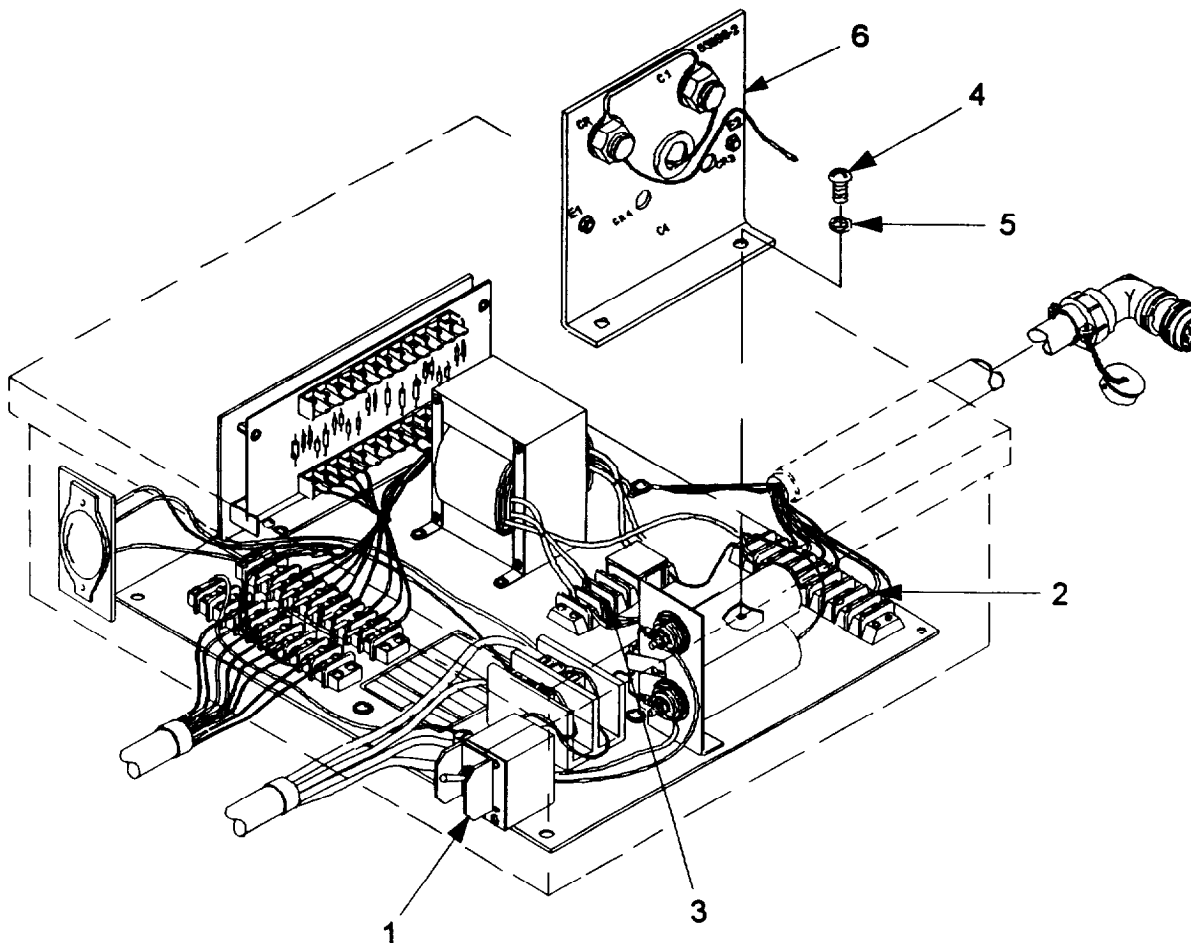



**5-50 ASSEMBLY OF ICB/LOW POWER CIRCUIT BREAKER ASSEMBLY (CB1) (9353915).****INITIAL SETUP****Tools and Special Tools:**

General mechanic's automotive tool kit  
 Heat gun  
 Soldering and desoldering set  
 Wire strippers  
 Crimping tool

**Materials/Parts:**

Circuit breaker (9353915)  
 Insulation sleeving (M23053/5-106-0)  
 Terminal lug (MS25036-153)  
 Wire (M16878/4BKEO)  
 Solder (item 11, appendix D)

- a. Cut four wires to lengths of 11.00 inches (27.94 cm), 11.00 inches (27.94 cm), 13.15 inches (33.40 cm), and 14.25 inches (36.12 cm).
- b. Strip back insulation on all wire ends 1/4 inch (.653 cm).
- c. Install terminal lug (1) to one end of each wire.
- d. Crimp tight.
- e. Slide insulation sleeving (2) over ends of each wire.
- f. Install two 11.00-inch (27.94 cm) leads to circuit breaker load terminals (3).
- g. Solder leads to load terminals.
- h. Install two remaining leads to circuit breaker line terminals (4).

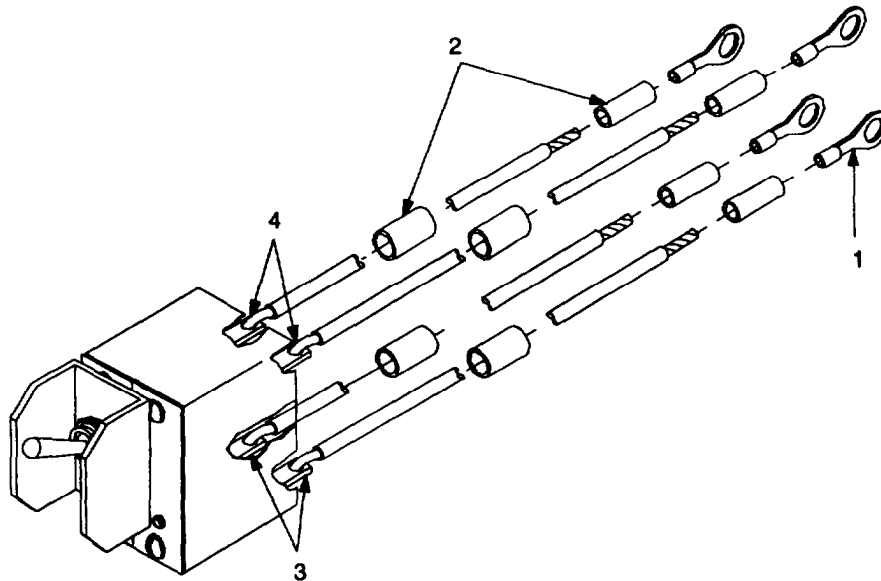

- i. Solder leads to line terminals.
- j. Slide insulation sleeving over all connections, apply heat and shrink tight.

5-51 ICB/LOW POWER TRANSFORMER ASSEMBLY REPLACEMENT (9354036).

**INITIAL SETUP**

**Tools and Special Tools:**

General mechanic's automotive tool kit

**Personnel Required:**

2 persons (for safety purposes)

**Materials/Parts:**

Transformer assembly (9354036)

**References:**

TM 9-6920-742-14-1

---

**a. Removal.**

- (1) Set CB1 (1) to the OFF position.
- (2) Remove power from 240 vac incoming power line.

**WARNING**



When working inside the equipment after power has been turned off, always ground every part before touching it. Failure to do so could result in serious injury or death.

- (3) Release latches and remove cover assembly.
- (4) Remove screws and lockwashers from TB4 (2) terminals 1, 2, 5, and 6.
- (5) Tag and remove four transformer leads from TB4.
- (6) Remove screw and lockwasher from TB3 (3) terminal 1.
- (7) Tag and remove transformer lead from TB3.
- (8) Remove screw (4) and lockwasher (5) from E4.
- (9) Tag and remove transformer ground lead from E4.
- (10) Remove four transformer mounting screws (6) and flatwashers (7).
- (11) Remove transformer (8) from mounting plate.

**b. Installation.**

- (1) Install transformer (8) to mounting plate.
- (2) Install four screws (6) and flatwashers (7) securing transformer to mounting plate.
- (3) Install transformer ground lead to E4 and secure with screw (4) and lockwasher (5).

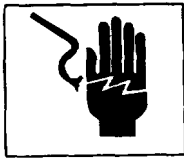

Ensure proper installation of transformer primary and secondary leads. Failure to do so could result in serious injury or death.

- (4) Install transformer primary leads to TB4 (2) terminals 5 and 6 and secure with screws and lockwashers.
- (5) Install transformer secondary leads to TB4 terminals 1 and 2 and secure with screws and lockwashers.

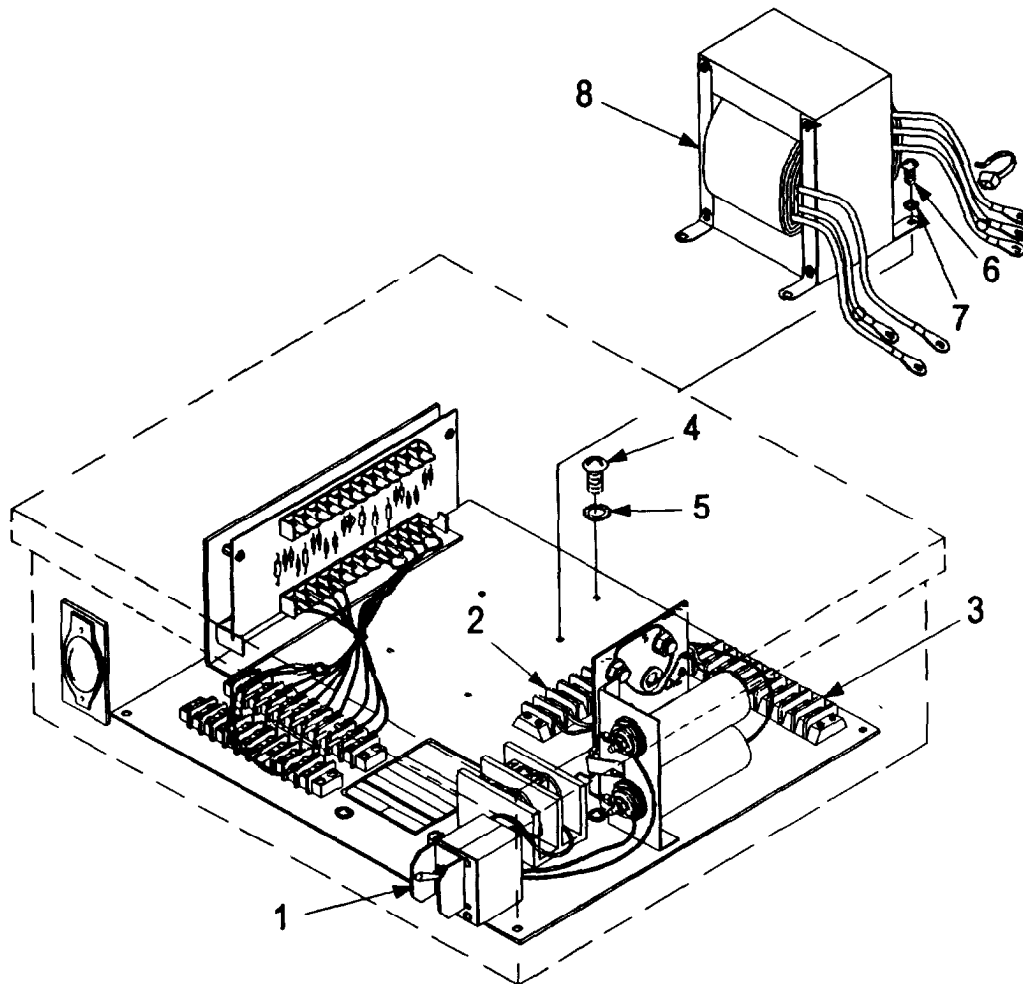

- (6) Install transformer center tap lead to TB3 (3) terminal 1 and secure with screw and lockwasher.
- (7) Install cover assembly and fasten latches.

**5-51 ICB/LOW POWER TRANSFORMER ASSEMBLY REPLACEMENT (9354036) (CONTINUED).**

- (8) Apply power to 240 vac incoming power line.
- (9) Set CB1 (1) to the ON position.
- (10) Test in accordance with TM 9-6920-742-14-1.

**5-52 ICB/LOW POWER TERMINAL LUG REPLACEMENT (MS25036-149).**

**INITIAL SETUP**

**Tools and Special Tools:**

General mechanic's automotive tool kit  
Wire strippers  
Crimping tool

**Personnel Required:**

2 persons (for safety purposes)

**References:**

TM 9-6920-742-14-1

**Materials/Parts:**

Terminal lug (MS25036-149)

---

- (1) Set CB1 (1) to the OFF position.
- (2) Remove power from 240 vac incoming power line.

**WARNING**



**When working inside the equipment after power has been turned off, always ground every part before touching it. Failure to do so could result in serious injury or death.**

- (3) Release latches and remove cover assembly.
- (4) Remove screws and lockwashers from TB4 (2) terminals 5 and 6 and E4 (3).
- (5) Tag and remove transformer assembly leads from TB4 and E4.
- (6) Cut terminal lug (4) from lead.
- (7) Strip insulation back 1/4 inch (.653 cm) from end of lead.
- (8) Install new terminal and crimp tight.
- (9) Repeat for other leads.

**WARNING**



Ensure proper installation of transformer primary and secondary leads. Failure to do so could result in serious injury or death.

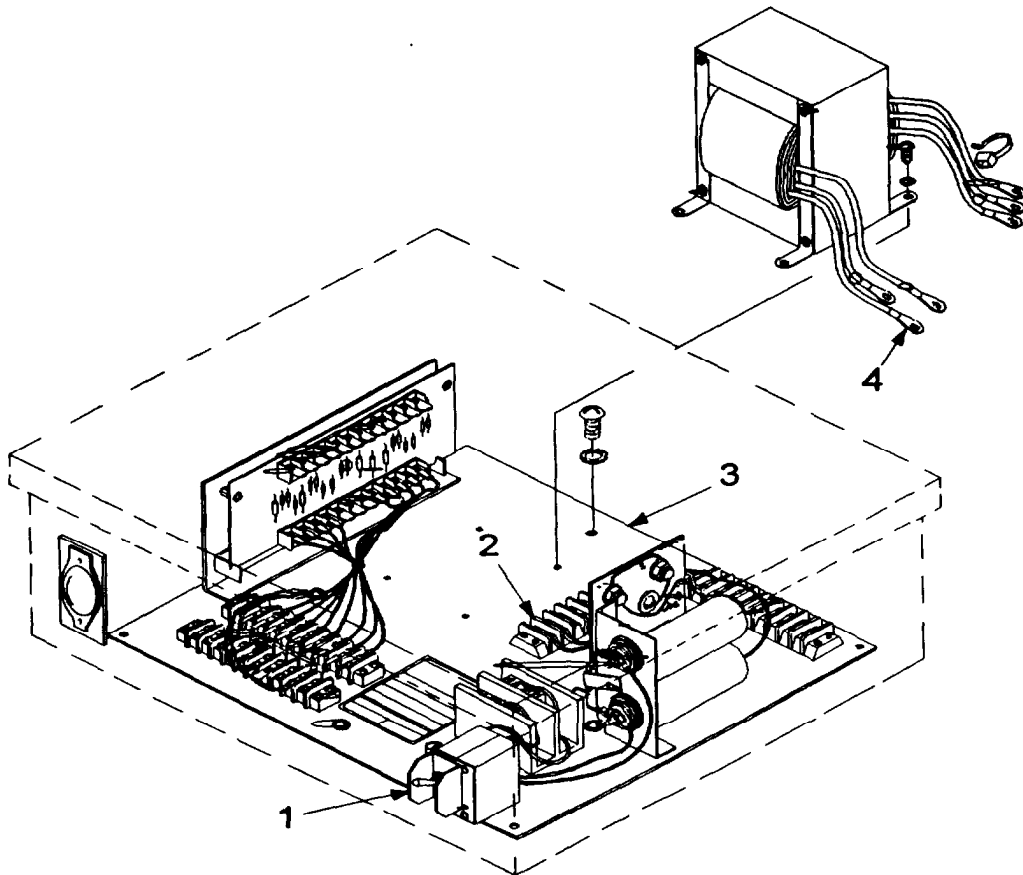

- (10) Install transformer leads to TB4 terminals 5 and 6 and E4.
- (11) Secure with screws and lockwashers.
- (12) Install cover assembly and fasten latches.
- (13) Apply power to 240 vac incoming power line.
- (14) Set CB1 to the ON position.
- (15) Test in accordance with TM 9-6920-742-14-1.

**5-53 ICB/LOW POWER TERMINAL LUG REPLACEMENT (MS25036-153).**

**INITIAL SETUP**

**Tools and Special Tools:**

General mechanic's automotive tool kit  
Wire strippers  
Crimping tool

**Personnel Required:**

2 persons (for safety purposes)

**References:**

TM 9-6920-742-14-1

**Materials/Parts:**

Terminal lug (MS25036-153)

---

- (1) Set CB1 (1) to the OFF position.
- (2) Remove power from 240 vac incoming power line.

**WARNING**



When working inside the equipment after power has been turned off, always ground every part before touching it. Failure to do so could result in serious injury or death.

- (3) Release latches and remove cover assembly.
- (4) Remove screws and lockwashers from TB4 (2) terminals 1 and 2 and TB3 (3) terminal 1.
- (5) Tag and remove transformer assembly leads from TB3 and TB4.
- (6) Cut terminal lug (4) from lead.
- (7) Strip insulation back 1/4 inch (.653 cm) from end of lead.
- (8) Install new terminal and crimp tight.
- (9) Repeat for other leads.

**WARNING**



Ensure proper installation of transformer primary and secondary leads. Failure to do so could result in serious injury or death.

- (10) Install transformer leads to TB4 terminals 1 and 2 and TB3 terminal 1.

- (11) Secure with screws and lockwashers.
- (12) Install cover assembly and fasten latches.
- (13) Apply power to 240 vac incoming power line.
- (14) Set CB1 to the ON position.
- (15) Test in accordance with TM 9-6920-742-14-1.

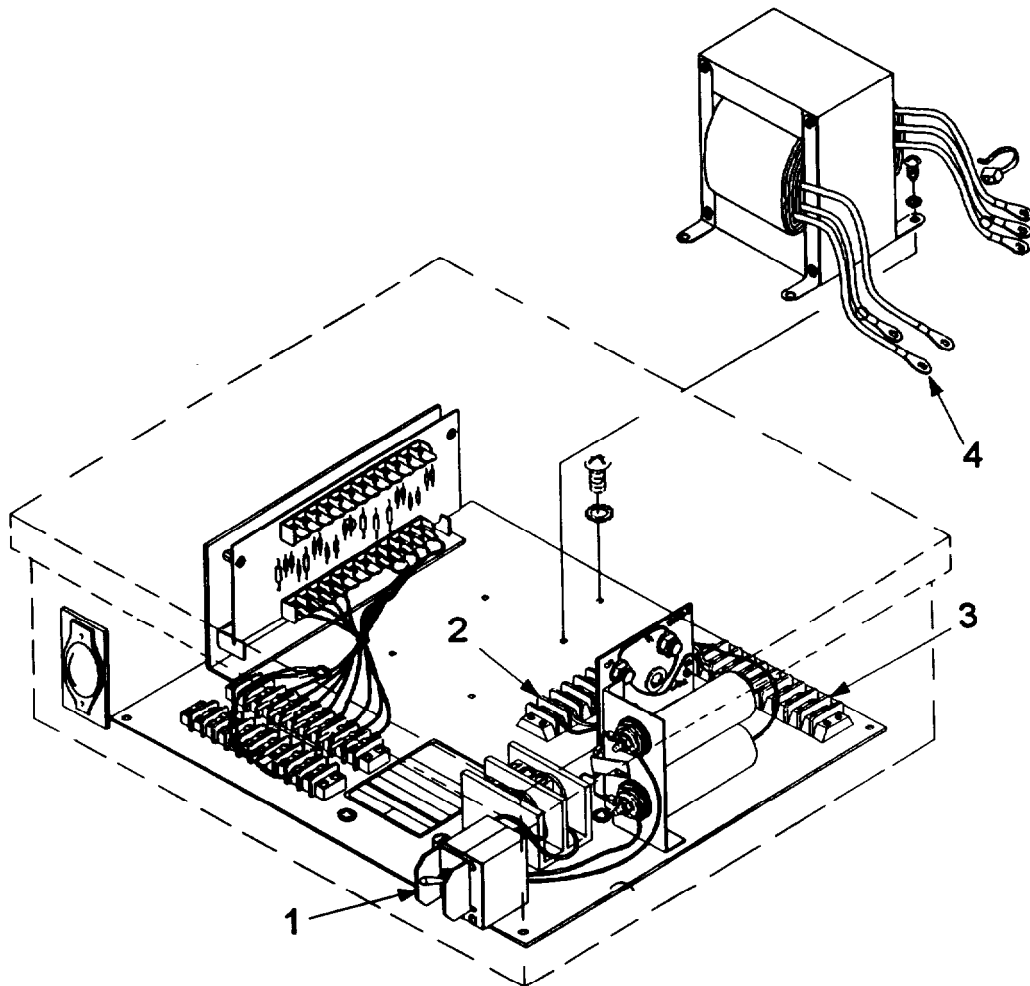

**5-54 ICB/LOW POWER JUMPER ASSEMBLY REPLACEMENT (9387197-1).**

**INITIAL SETUP**

**Tools and Special Tools:**

General mechanic's automotive tool kit

**Personnel Required:**

2 persons (for safety purposes)

**Materials/Parts:**

Jumper assembly (9387197-1)

Tiedown strap (MS3368-1-9B)

**References:**

TM 9-6920-742-14-1

---

**a. Removal.**

- (1) Set CB1 to the OFF position.
- (2) Remove power from 240 vac incoming power line.

**WARNING**



**When working inside the equipment after power has been turned off, always ground every part before touching it. Failure to do so could result in serious injury or death.**

- (3) Release latches and remove cover assembly.
- (4) Remove screw (1) and lockwasher (2) from E5.
- (5) Remove screw (3) and lockwasher (4) from TB1 terminal 9 (5).
- (6) Cut tiedown straps (6) and remove jumper assembly (7).

**b. Installation.**

- (1) Install jumper assembly (7) to E5 and secure with screw (1) and lockwasher (2).
- (2) Install jumper assembly to TB1 terminal 9 (5) and secure with screw (3) and lockwasher (4).
- (3) Install tiedown straps (6) as necessary.
- (4) Install cover assembly and fasten latches.
- (5) Apply power to 240 vac incoming power line.
- (6) Set CB1 to the ON position.
- (7) Test in accordance with TM 9-6920-742-14-1.



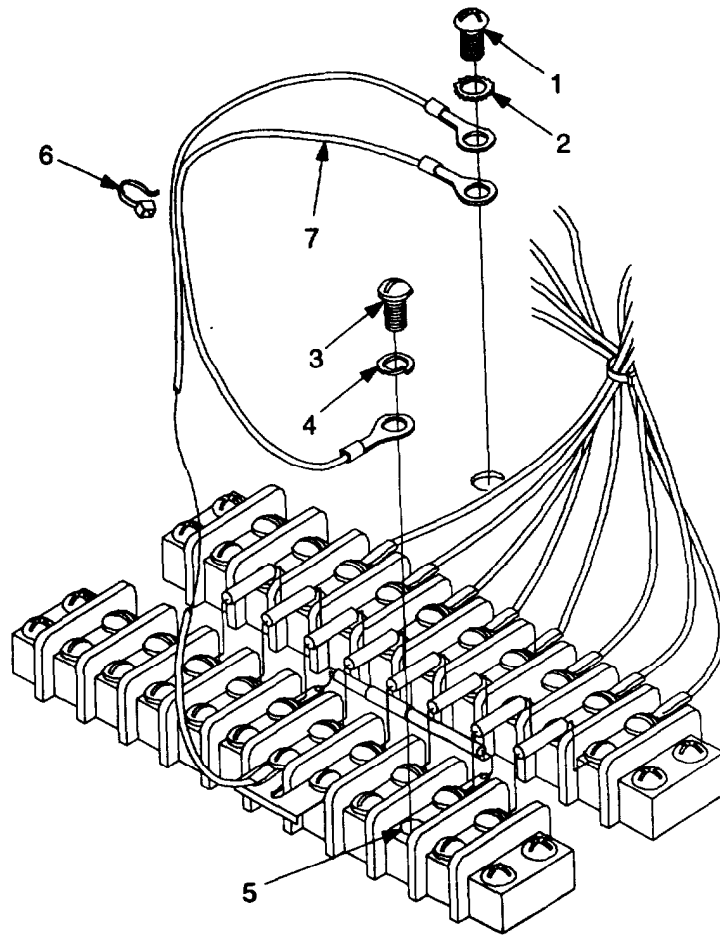

5-55 ASSEMBLY OF ICB/LOW POWER JUMPER ASSEMBLY (9387197-1).

INITIAL SETUP

**Tools and Special Tools:**

Crimping tool  
Wire strippers

**Materials/Parts:**

Terminal lug (MS25036-101)  
Terminal lug (MS25036-149)  
Wire (M16878/4BHEO)

---

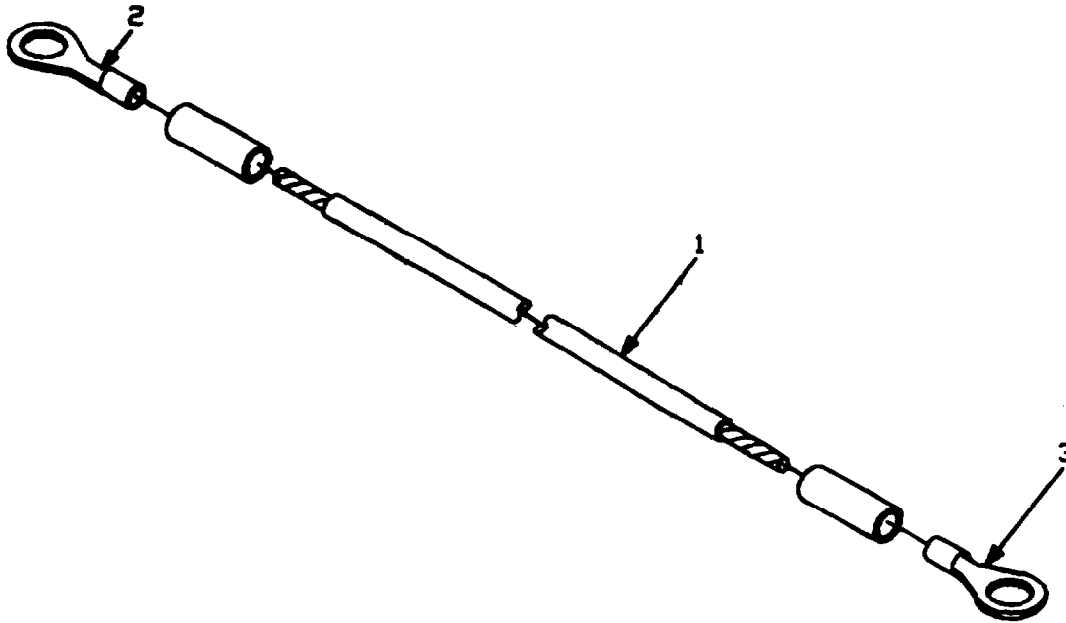

- a. Cut wire (1) to 7.8-inch (19.81 cm) length.
- b. Strip back insulation 1/4 inch (.653 cm) on both ends.
- c. Install terminal lug (2) (MS25036-101) to one wire end and crimp tight.
- d. Install terminal lug (3) (MS25036-149) to other end of wire and crimp tight.

**THIS PAGE INTENTIONALLY LEFT BLANK**

**5-56 ICB/LOW POWER JUMPER ASSEMBLY REPLACEMENT (9387197-2).**

**INITIAL SETUP**

**Tools and Special Tools:**

General mechanic's automotive tool kit

**Personnel Required:**

2 persons (for safety purposes)

**Materials/Parts:**

Jumper assembly (9387197-2)

Tiedown strap (MS3368-1-9B)

**References:**

TM 9-6920-742-14-1

---

**a. Removal.**

- (1) Set CB1 to the OFF position
- (2) Remove power from 240 vac incoming power line.

**WARNING**



When working inside the equipment after power has been turned off, always ground every part before touching it. Failure to do so could result in serious injury or death.

- (3) Release latches and remove cover assembly.
- (4) Remove screw (1) and lockwasher (2) from E5.
- (5) Remove screw (3) and lockwasher (4) from TB1 terminal 6 (5).
- (6) Cut tiedown straps (6) and remove jumper assembly (7).

**b. Installation.**

- (1) Install jumper assembly (7) to E5 and secure with screw (1) and lockwasher (2).
- (2) Install jumper assembly to TB1 terminal 6 (5) and secure with screw (3) and lockwasher (4).
- (3) Install tiedown straps (6) as necessary.
- (4) Install cover assembly and fasten latches.
- (5) Apply power to 240 vac incoming power line.
- (6) Set CB1 to the ON positions.
- (7) Test in accordance with TM 9-6920-742-14-1.

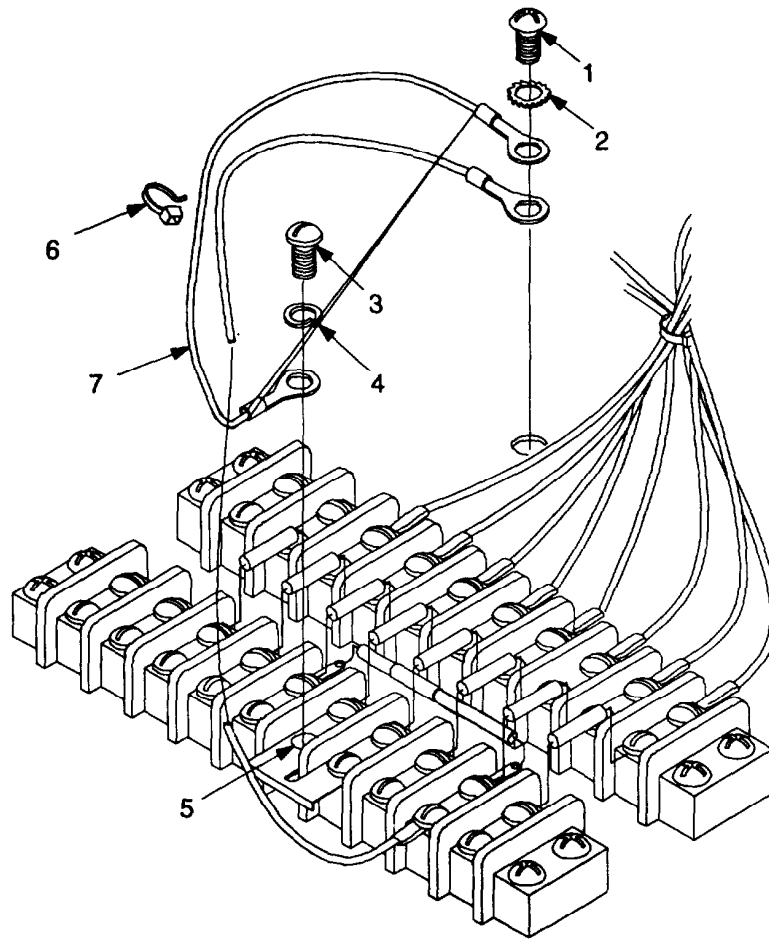

**5-57 ASSEMBLY OF ICB/LOW POWER JUMPER ASSEMBLY (9387197-2).**

**INITIAL SETUP**

**Tools and Special Tools:**

Crimping tool  
Wire strippers

**Materials/Parts:**

Terminal lug (MS25036-101)  
Terminal lug (MS25036-149)  
Wire (M16878/4BHEO)

---

- a. Cut wire (1) to 8.8-inch (22.35 cm) length.
- b. Strip back insulation 1/4 inch (.653 cm) on both ends.
- c. Install terminal lug (2) (MS25036-101) to one wire end and crimp tight.
- d. Install terminal lug (3) (MS25036-149) to other end of wire and crimp tight.

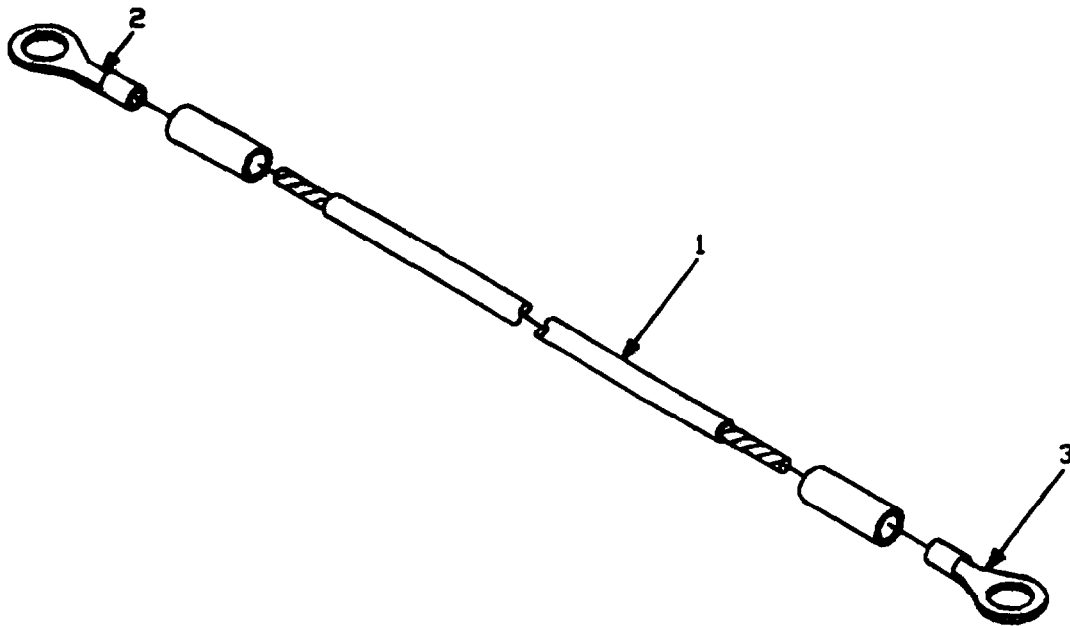

**5-58 ICB/LOW POWER CONNECTOR P3 REPLACEMENT (MS3476W20-39P).****INITIAL SETUP****Tools and Special Tools:**

General mechanic's automotive tool kit  
 Heat gun  
 Soldering and desoldering set  
 Wire strippers  
 Crimping tool

**Materials/Parts:**

Connector (MS3476W20-39P)  
 Insulation sleeving (M23053/5-310-0)  
 Wire (M16878/4BGE9)

**Materials/Parts (Continued):**

Connector (9353932)  
 Solder (item 11, appendix D)  
 Tape (item 13, appendix D)  
 Sealing compound (item 8, appendix D)

**Personnel Required:**

2 persons (for safety purposes)

**References:**

TM 9-6920-742-14-1

- (1) Set CB1 to the OFF position.
- (2) Remove power from 240 vac incoming power line.

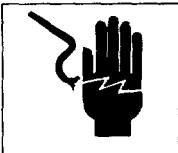
**WARNING**

**When working inside the equipment after power has been turned off, always ground every part before touching it. Failure to do so could result in serious injury or death.**

- (3) Release latches and remove cover assembly.
- (4) Remove leads from TB7 terminals 3, 4, 6, 7, 8, 9, 10, 11, and 12.
- (5) Remove connector P3 from J3 of ITM or J2 of TIU and remove cable assembly.
- (6) Remove two screws (1) from strain relief (2) on backshell (3) attached to connector P3 (4).
- (7) Remove connector P3 from backshell and expose wiring.
- (8) Cut wiring as close as possible to connector P3 and remove.

**NOTE**

**If cable will be shortened to less than a serviceable length by replacing connector, cable must be replaced.**

- (9) Strip outer insulation on cable 2 inches (5.08 cm) from end.
- (10) Tape end of cable insulation and position backshell over cable.
- (11) Fan overall shield (5) and twist together.

**5-58 ICB/LOW POWER CONNECTOR P3 REPLACEMENT (MS3476W20-39P) (CONTINUED).**

- (12) Tin end of overall shield approximately 1/2 inch (1.27 cm).
- (13) Strip insulation back 1/4 inch (.653 cm) from end of piece of 20 AWG wire (6) and solder to tinned shield.

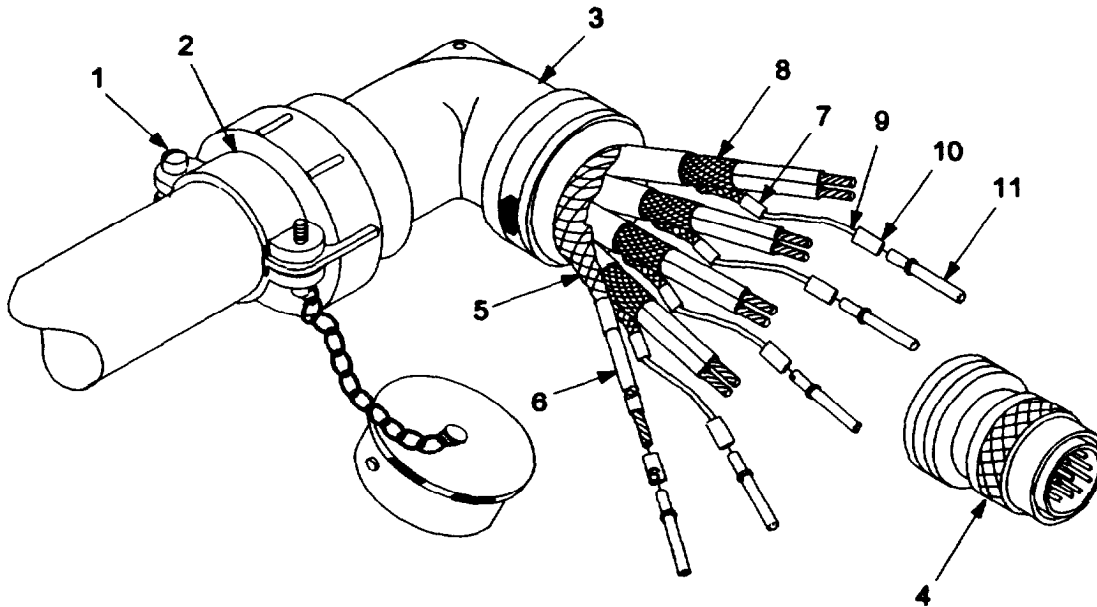

- (14) Install connector (7) over an inner shield (8).
- (15) Strip insulation back 1/4 inch (.653 cm) from end of piece of 20 AWG wire (9).
- (16) Insert stripped end of 20 AWG wire into splice connector and crimp tight.
- (17) Using the same procedure, crimp 20 AWG wires to remaining three inner shields.
- (18) Remove tape from end of cable insulation.
- (19) Strip insulation back 1/4 inch (.653 cm) from ends of 16 cable leads.
- (20) Slide insulation (10) sleeving over ends of cable leads.
- (21) Attach pins (11) to cable leads and solder in place.
- (22) Slide insulation sleeving over pin connections.
- (23) Apply heat and shrink insulation sleeving over connections.
- (24) Using the following table, insert pins into connector P3.



PIN	WIRE COLOR
A	blue/blk
B	grn/blk
C	orn/blk
c	red/blk
d	gray/blk
X	C and D pair inner shield
e	blk
f	gray
Y	E and F pair inner shield
i	red
j	grn
Z	I and J pair inner shield
h	blue
g	orn
b	H and G pair inner shield
L	overall shield

- (25) Apply sealing compound to threads of connector P3.
- (26) Install connector P3 to backshell.
- (27) Install and tighten two screws on strain relief on backshell.
- (28) Install cable assembly leads to TB7 terminals 3, 4, 6, 7, 8, 9, 10, 11, and 12.
- (29) Install connector P3 to J3 of ITM or J2 of TIU.
- (30) Install cover assembly and fasten latches.
- (31) Apply power to 240 vac incoming power line.
- (32) Set CB1 to the ON position.
- (33) Test in accordance with TM 9-6920-742-14-1.

5-59 ICB/LOW POWER TERMINAL LUG REPLACEMENT (9354176).

INITIAL SETUP

**Tools and Special Tools:**

General mechanic's automotive tool kit  
Wire strippers  
Crimping tool

**Personnel Required:**

2 persons (for safety purposes)

**References:**

TM 9-6920-742-14-1

**Materials/Parts:**

Terminal lug (9354176)

---

- (1) Set CB1 to the OFF position.
- (2) Remove power from 240 vac incoming power line.

**WARNING**



When working inside the equipment after power has been turned off, always ground every part before touching it. Failure to do so could result in serious injury or death.

- (3) Release latches and remove cover assembly.
- (4) Remove lead to be replaced from TB7 terminal.

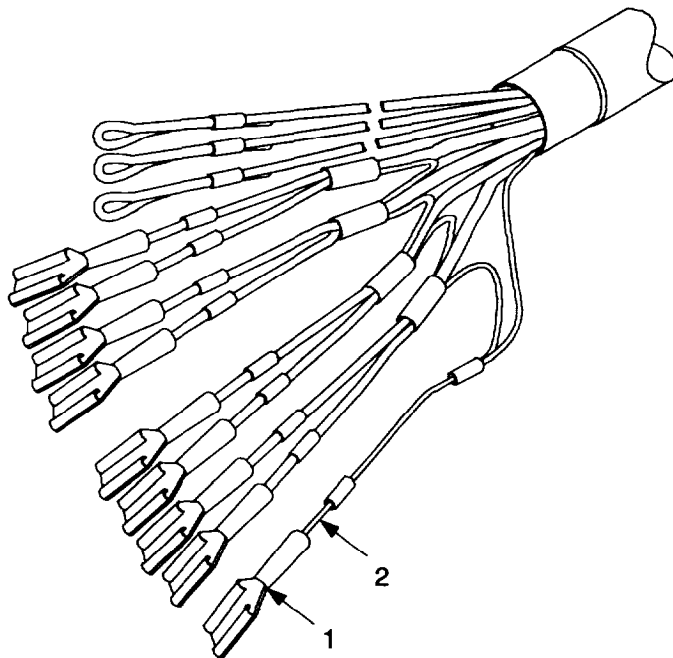

- (5) Cut terminal lug (1) from lead (2) as close to terminal lug as possible.
- (6) Strip back insulation 1/4 inch (.653 cm) from end of lead.
- (7) Install new terminal lug and crimp tight.
- (8) Install lead to TB7 terminal.
- (9) Repeat procedure for other terminal lugs being replaced.
- (10) Install cover assembly and fasten latches.
- (11) Apply power to 240 vac incoming power line.
- (12) Set CB1 to the ON position.
- (13) Test in accordance with TM 9-6920-742-14-1.

#### 5-60 ICB/LOW POWER CONNECTOR REPLACEMENT (9353932).

##### INITIAL SETUP

##### Tools and Special Tools:

General mechanic's automotive tool kit  
Crimping tool

##### Personnel Required:

2 persons (for safety purposes)

##### Materials/Parts:

Connector (9353932)

##### References:

TM 9-6920-742-14-1

- (1) Set CB1 to the OFF position.
- (2) Remove power from 240 vac incoming power line.

#### WARNING



**When working inside the equipment after power has been turned off, always ground every part before touching it. Failure to do so could result in serious injury or death.**

- (3) Release latches and remove cover assembly.
- (4) Remove leads from TB7 terminals 3, 4, 6, 7, 8, 9, 10, 11, and 12.
- (5) Remove connector P3 from J3 of ITM or J2 of TIU and remove cable assembly.
- (6) Pry connector (1) from TB7-12 and TB7-11 pair shield and 20 AWG wire (2).

5-60 ICB/LOW POWER CONNECTOR REPLACEMENT 99353932) (CONTINUED).

- (7) Install new connector over inner shield and 20 AWG wire and crimp tight.

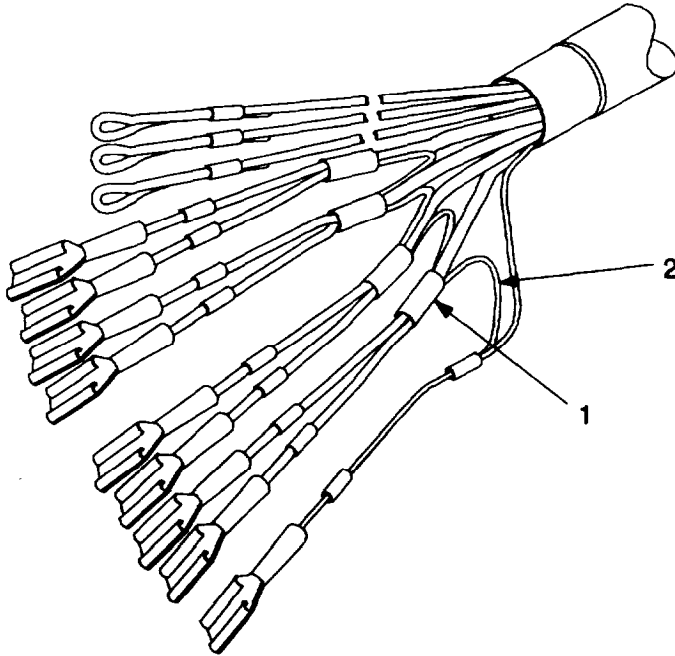

- (8) Repeat process for TB7-10 and TB7-5 pair shield, TB7-3 and TB7-8 pair shield, and TB7-6 and TB7-7 pair shield.
- (9) Install cable assembly leads to TB7 terminals 3, 4, 6, 7, 8, 9, 10, 11, and 12.
- (10) Install connector P3 to J3 of ITM or J2 of TIU.
- (11) Install cover assembly and fasten latches.
- (12) Apply power to 240 vac incoming power line.
- (13) Set CB1 to the ON position.
- (14) Test in accordance with TM 9-6920-742-14-1.

**5-61 ICB/LOW POWER CONNECTOR P2 REPLACEMENT (MS312E16-14S).****INITIAL SETUP****Tools and Special Tools:**

General mechanic's automotive tool kit  
Heat gun  
Soldering and desoldering set  
Wire strippers

**Materials/Parts (Continued):**

Wire (M22759/11-20-9)  
Solder (item 11, appendix D)  
Tape (item 13, appendix D)  
Sealing compound (item 8, appendix D)

**Materials/Parts:**

Connector (MS312E16-14S)  
Insulation sleeving (M23053/5-308-0)

**Personnel Required:**

2 persons (for safety purposes)

**References:**

TM 9-6920-742-14-1

- (1) Set CB1 to the OFF position.
- (2) Remove power from 240 vac incoming power line.

**WARNING**

**When working inside the equipment after power has been turned off, always ground every part before touching it. Failure to do so could result in serious injury or death.**

- (3) Release latches and remove cover assembly.
- (4) Remove screws and lockwashers from TB3 terminals 2, 3, 4, 5, 8, 9, and E4.
- (5) Remove leads from TB3 and E4.
- (6) Remove connector P2 from J1 of TIU or ITM and remove cable assembly.
- (7) Remove two screws (1) from strain relief (2) on backshell (3) attached to connector P2 (4).
- (8) Remove connector P2 from backshell and expose wiring.
- (9) Cut wiring as close to connector P2 as possible and remove.

**NOTE**

**If cable will be shortened to less than a serviceable length by replacing connector, cable must be replaced.**

- (10) Strip outer insulation on cable 2 inches (5.08 cm) from end.
- (11) Tape end of cable insulation and position backshell over cable.

**5-61 ICB/LOW POWER CONNECTOR P2 REPLACEMENT (MS312E16-14S) (CONTINUED).**

**(12)** Fan overall shield (5) and twist together.

**(13)** Tin end of overall shield approximately 1/2 inch (1.27 cm).

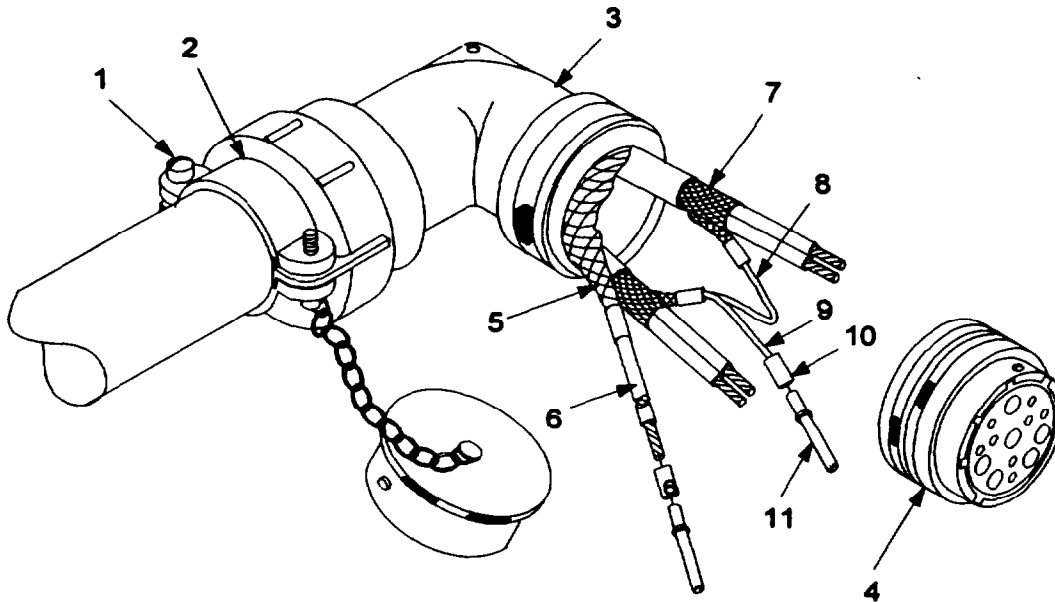

**(14)** Strip insulation back 1/4 inch (.653 cm) from end of piece of 20 AWG wire (6) and solder to tinned shield.

**(15)** Tin end of green and red pair inner shield (7) approximately 1/2 inch (1.27 cm).

**(16)** Using the same procedure, tin end of orange and blue pair inner shield and connect to green and red pair inner shield using wire (8).

**(17)** Strip insulation back 1/4 inch (.653 cm) from end of piece of 20 AWG wire (9).

**(18)** Solder 20 AWG wire to tinned inner shield.

**(19)** Remove tape from end of cable insulation.

**(20)** Strip insulation back 1/4 inch (.653 cm) from ends of 11 cable leads.

**(21)** Slide insulation sleeving (10) over ends of cable leads.

**(22)** Attach pins (11) to cable leads and solder in place.

**(23)** Slide insulation sleeving over pin connections.

**(24)** Apply heat and shrink insulation sleeving over connections.

**(25)** Using the following table, insert pins into connector P2.

PIN	WIRE COLOR
D	orn
G	blue
E	grn
H	red
K	D and G pair and E and H pair shield
A	blk
P	gray
F	overall shield

- (26) Apply sealing compound to threads of connector P2.
- (27) Install connector P2 to backshell.
- (28) Install and tighten two screws on strain relief on backshell.
- (29) Install cable leads to TB3 terminals 2, 3, 4, 5, 8, 9, and E4 and secure with screws and lockwashers.
- (30) Install connector P2 to J1 of ITM or TIU.
- (31) Install cover assembly and fasten latches.
- (32) Apply power to 240 vac incoming power line.
- (33) Set CB1 to the ON position.
- (34) Test in accordance with TM 9-6920-742-14-1.

**5-62 ICB/LOW POWER TERMINAL LUG REPLACEMENT (MS25036-156).**

**INITIAL SETUP**

**Tools and Special Tools:**

General mechanic's automotive tool kit  
Wire strippers  
Crimp connectors

**Personnel Required:**

2 persons (for safety purposes)

**References:**

TM 9-6920-742-14-1

**Materials/Parts:**

Terminal lug (MS25036-156)

---

- (1) Set CB1 to the OFF position.
- (2) Remove power from 240 vac incoming power line.

**WARNING**



When working inside the equipment after power has been turned off, always ground every part before touching it. Failure to do so could result in serious injury or death.

- (3) Release latches and remove cover assembly.
- (4) Remove screw and lockwasher from TB3 terminal lug to be replaced.
- (5) Remove terminal lug from TB3.
- (6) Cut terminal lug (1) from lead (2) as close to terminal lug as possible.
- (7) Strip back insulation 1/4 inch (.653 cm) from end of lead.
- (8) Install new terminal lug and crimp tight.
- (9) Install lead to TB3 terminal and secure using screw and lockwasher.
- (10) Repeat procedure for other terminal lugs being replaced.
- (11) Install cover assembly and fasten latches.
- (12) Apply power to 240 vac incoming power line.
- (13) Set CB1 to the ON position.
- (14) Test in accordance with TM 9-6920-742-14-1.



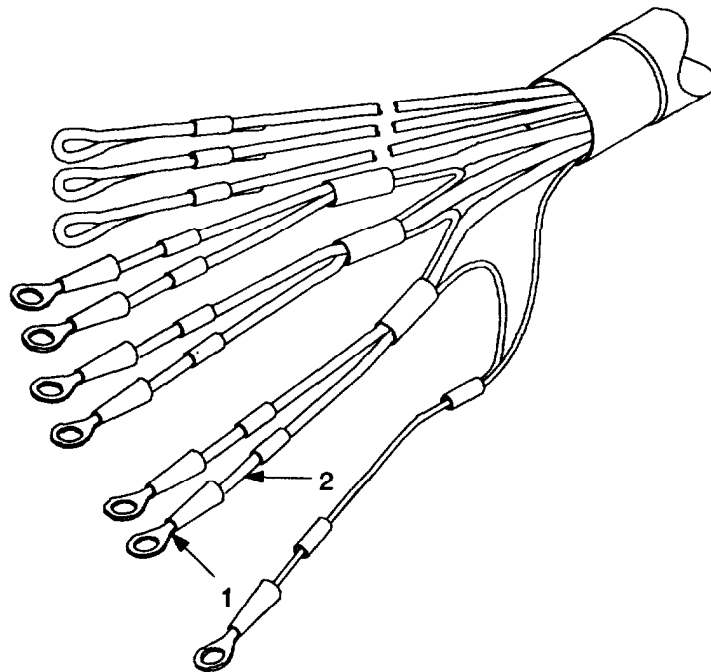

**5-63 ICB/LOW POWER TERMINAL LUG REPLACEMENT (MS25036-149).**

**INITIAL SETUP**

**Tools and Special Tools:**

- General mechanic's automotive tool kit
- Wire strippers
- Crimping tool

**Personnel Required:**

2 persons (for safety purposes)

**References:**

TM 9-6920-742-14-1

**Materials/Parts:**

Terminal lug (MS25036-149)

- (1) Set CB1 to the OFF position.
- (2) Remove power from 240 vac incoming power line.

**WARNING**



When working inside the equipment after power has been turned off, always ground every part before touching it. Failure to do so could result in serious injury or death.

**5-63 ICB/LOW POWER TERMINAL LUG REPLACEMENT (MS25036-149) (CONTINUED).**

- (3) Release latches and remove cover assembly.
- (4) Remove screw and lockwasher from E4 terminal.
- (5) Remove terminal lug from E4.

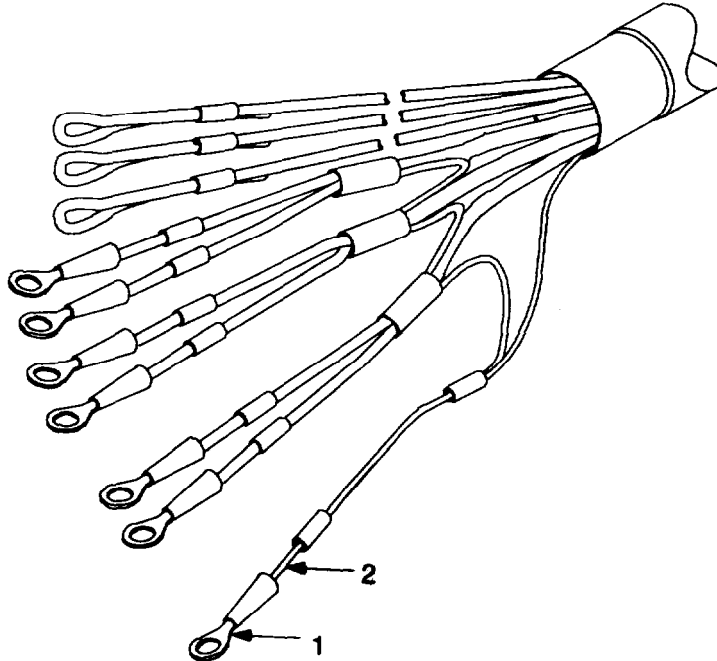

- (6) Cut terminal lug (1) from lead (2) as close to terminal lug as possible.
- (7) Strip back insulation 1/4 inch (.653 cm) from end of lead.
- (8) Install new terminal lug and crimp tight.
- (9) Install lead to E4 terminal and secure using screw and lockwasher.
- (10) Install cover assembly and fasten latches.
- (11) Apply power to 240 vac incoming power line.
- (12) Set CB1 and CB2 to the ON position.
- (13) Test in accordance with TM 9-6920-742-14-1.

**5-64 ASSEMBLY AND INITIAL INSTALLATION OF ICB/LOW POWER OUTLET ASSEMBLY (12974140).**

**INITIAL SETUP**

**Tools and Special Tools:**

- Soldering and desoldering set
- Wire strippers
- Heat gun
- Drill Motor
- Drill Bit #20
- Chassis Punch (1.578-1.609)

**Materials/Parts (Continued):**

- Outlet Cover (12974141)
- Outlet (W-C-596/81-1)
- Insulation sleeving (M23053/5-107-4)
- Insulation sleeving (M23053/5-105-4)
- Wire Electrical (M22759/11-12-5)
- Wire Electrical (M22759/11-12-9)
- Tiedown straps (MS3367-5-9)
- Solder (item 11, appendix D)

**a. Assembly.**

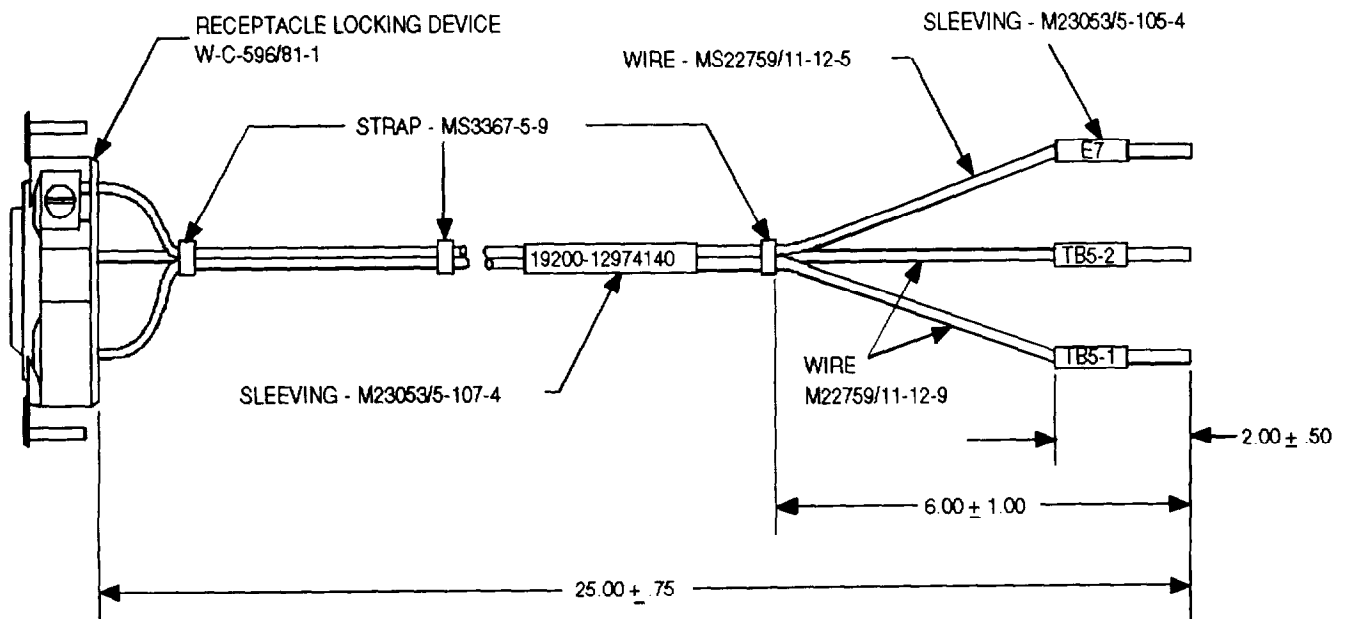

- (1) Cut two pieces of 12AWG white wire (M22759/11-12-9) to length as shown and attach them to the outlet receptacle, pins X and Y.
- (2) Cut a piece of 12AWG green wire (M22759/11-12-5) to length as shown and attach it to the outlet receptacle, pin G.
- (3) Slide a piece of insulation sleeving (marked with 19200 - 12974140) over each of the three separate ends and position as shown. Shrink to fit with a heat gun.

**NOTE**

**Ensure that tiedown straps are not applied any closer than 6 inches (15.24 cm) from the end of the wire bundle furthest from the outlet receptacle.**

**5-64 ASSEMBLY AND INITIAL INSTALLATION OF ICB/LOW POWER OUTLET ASSEMBLY (12974140) (CONTINUED).**

- (4) Install tiedown straps (as required) to secure wire bundle.
- (5) Strip ends of outlet assembly wires approximately one inch (2.54 cm) from the end as shown.
- (6) Cut and attach 3 pieces of wire indicator, insulation sleeving (mark these with E7, TB5-2, TB5-1) over the correct wires. TB5-1 connects to outlet pin Y, TB5-2 connects to outlet pin X, and E7 connects to outlet pin G. Shrink to fit with a heat gun.

**b. Installation.**

**MODIFICATIONS TO ENCLOSURE**

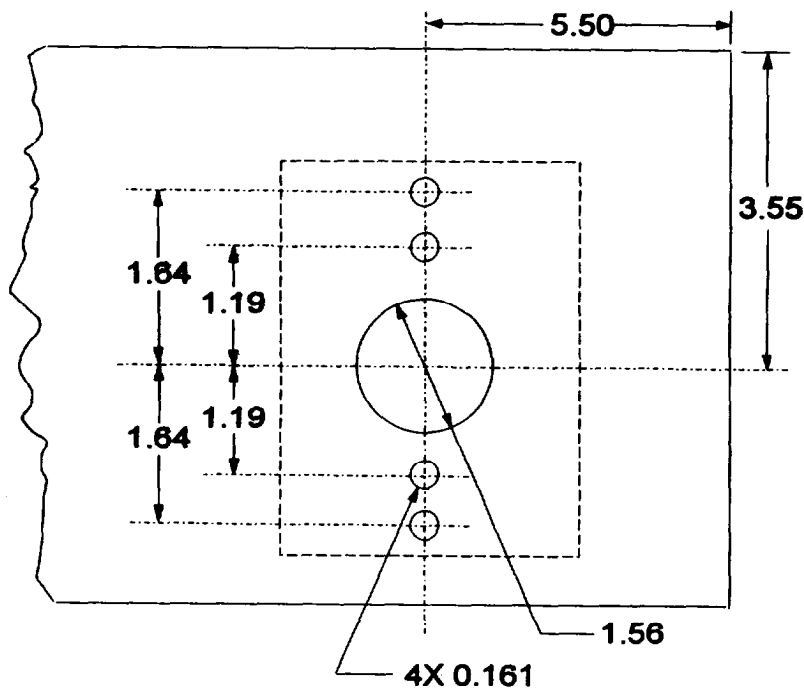

**NOTE**

The following instructions are for initial installation, when a mounting hole is not available on the ICB/Low Power enclosure.

**NOTE**

Check to see that no interference exists between the operation of the cover and the installation of the outlet. Various styles and sizes of junction boxes may require different outlet assembly installation locations.

- (1) Set CB1 on the ICB/Low Power to the **OFF** position.
- (2) Remove power from 240 vac incoming power line.

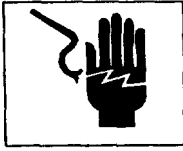
**WARNING**

When working inside the equipment after power has been turned off, always ground every part before touching it. Failure to do so could result in serious injury or death.

- (3) Release latches and remove cover assembly.
- (4) Locate outlet on your particular enclosure in the best place possible.
- (5) Drill two outlet mounting holes, two outlet cover mounting holes, and cut out one outlet receptacle opening as shown.
- (6) Clean out any metal residue filings.
- (7) Remove two outlet fastening screws that are assembled on the outlet and fasten outlet to J-Box enclosure.
- (8) Cut out opening from sealing gasket to fit outlet.

**NOTE**

**Before fastening attachment screws, be certain that gasket is seated properly between the J-Box wall and cover plate. Gasket material should be visible and protrude slightly outside the outer edge of the cover plate for proper seal.**

- (9) Assemble outlet cover and sealing gasket and fasten with outlet cover screws that come with the outlet cover.
- (10) Remove two screws and remove the power block cover on TB5.
- (11) Connect the wires marked TB5-1 and TB5-2 to TB5 and the wire marked E7 to ground lug E7.
- (12) Install power block cover on TB5 with two screws.
- (13) Install cover assembly and fasten latches.
- (14) Apply power to the 240 vac incoming power line.
- (15) Set CB1 on the ICB/Low power to the ON position.
- (16) Check the outlet assembly for 240 vac.



## APPENDIX A

### REFERENCES

#### **A-1 SCOPE.**

This appendix lists all forms, technical manuals, and miscellaneous publications referenced in this manual.

#### **A-2 PUBLICATION INDEXES.**

The following publication indexes should be consulted frequently for latest changes or revisions of references given in this appendix and for new publications relating to material covered in this manual:

Consolidated Index of Army Publications and Blank Forms . . . . . DA PAM 25-30

The Army Maintenance Management System (TAMMS) . . . . . DA PAM 738-750

#### **A-3 TECHNICAL PUBLICATIONS.**

Unit, Direct Support, and General Support Maintenance Repair Parts and Special Tool Lists/ Illustrated Parts Breakdown (Including Depot Repair Parts and Special Tools), Enhanced Remoted Target System (ERETS) Interconnecting Box, Target Interface; Interconnecting Box, High Power; and Interconnecting Box, Low Power . . . . . TM 9-6920-742-24P-4

Operator, Unit, Direct Support, and General Support Maintenance Manual, Enhanced Remoted Target System (ERETS) Simulator, Armor Target Kill . . . . . TM 9-6920-742-14-2

Operator, Unit, Direct Support, and General Support Maintenance Manual, Enhanced Remoted Target System (ERETS) Console, Target Training Set-ERETS . . . . . TM 9-6920-742-14-1

Soldering Techniques . . . . . TB SIG 222

Destruction of Army Materiel to Prevent Enemy Use . . . . . TM 750-244-3

Painting . . . . . TM 43-0139

Safety Requirements for Maintenance of Electrical and Electronics Equipment . . . . . TB 385-4

#### **A-4 FIELD MANUALS.**

First Aid for Soldiers . . . . . FM 21-11

#### **A-5 FORMS.**

Product Quality Deficiency Report . . . . . SF 368

Accident Report . . . . . DA Form 285

Recommended Changes to Publications and Blank Forms . . . . . DA Form 2028





## APPENDIX B

### MAINTENANCE ALLOCATION CHART

#### SECTION I. INTRODUCTION

##### **B-1 GENERAL.**

This section provides a general explanation of all maintenance and repair functions authorized at various maintenance levels.

The MAC in Section II designates overall authority and responsibility for the performance of maintenance functions on the Interconnecting Box, Target Interface (TIU); Interconnecting Box, High Power (ICB/High Power); and Interconnecting Box, Low Power (ICB/Low Power). The application of the maintenance functions to the TIU, ICB/High Power, and ICB/Low Power will be consistent with the capacities and capabilities of the designated maintenance levels.

Section III lists the tools and test equipment (both special tools and common tool sets) required for each maintenance function as referenced from Section II.

Section IV contains supplemental instructions and explanatory notes for a particular maintenance function.

##### **B-2 MAINTENANCE FUNCTIONS.**

Maintenance functions will be limited to and defined as follows:

- a. **Inspect.** To determine the serviceability of an item by comparing its physical, mechanical, and/or electrical characteristics with established standards through examination (e.g., by sight, sound, or feel).
- b. **Test.** To verify serviceability by measuring the mechanical, pneumatic, hydraulic, or electrical characteristics of an item and comparing those characteristics with prescribed standards.
- c. **Service.** Operations required periodically to keep an item in proper operating condition, i.e., to clean (includes decontaminate when required), to preserve, to drain, to paint, or to replenish fuel, lubricants, chemical fluids or gases.
- d. **Adjust.** To maintain or regulate, within prescribed limits, by bringing into proper or exact position or by setting the operating characteristics to specified parameters.
- e. **Align.** To adjust specified variable elements of an item to bring about optimum or desired performance.
- f. **Calibrate.** To determine and cause corrections to be made or to be adjusted on instruments or test, measuring, and diagnostic equipments used in precision measurement. Consists of comparisons of two instruments, one of which is a certified standard of known accuracy, to detect and adjust any discrepancy in the accuracy of the instrument being compared.

## **B-2 MAINTENANCE FUNCTIONS (CONTINUED).**

**g. Remove/Install.** To remove and install the same item when required to perform service or other maintenance functions. Install may be the act of emplacing, seating, or fixing into position a spare, repair part, or module (component or assembly) in a manner to allow the proper functioning of an equipment or system.

**h. Replace.** To remove an unserviceable item and install a serviceable counterpart in its place. Replace is authorized by the MAC and is shown as the 3rd position code of the SMR code.

**i. Repair.** The application of maintenance services<sup>1</sup>, including fault location/troubleshooting<sup>2</sup>, removal/installation, and disassembly/assembly<sup>3</sup> procedures, and maintenance actions<sup>4</sup> to identify troubles and restore serviceability to an item by correcting specific damage, fault, malfunction or failure in a part, subassembly, module (component or assembly), end item or system.

**i. Overhaul.** That maintenance effort (service/action) prescribed to restore an item to a completely serviceable/operational condition as required by maintenance standards in appropriate technical publications. Overhaul is normally the highest degree of maintenance performed by the Army. Overhaul does not normally return an item to like-new condition.

**i. Rebuild.** Consists of those services/actions necessary for the restoration of unserviceable equipment to a like-new condition in accordance with original manufacturing standards. Rebuild is the highest degree of materiel maintenance applied to Army equipment. The rebuild operation includes the act of returning to zero those age measurements (hours/miles, etc) considered in classifying Army equipment/components.

## **B-3 EXPLANATION OF COLUMNS IN THE MAC. SECTION II.**

**a. Column 1, Group Number.** Column 1 lists functional group code numbers, the purpose of which is to identify maintenance significant components, assemblies, subassemblies, and modules with the next higher assembly. End item group number shall be 00.

**b. Column 2, Component/ Assembly.** Column 2 contains the names of components, assemblies, subassemblies, and modules for which maintenance is authorized.

**c. Column 3, Maintenance Function.** Column 3 lists the functions to be performed on the item listed in column 2. (For detailed explanation of these functions, see paragraph B-2.)

---

**1** Services - inspect, test, service, adjust, align, calibrate, and/or replace.

**2** Fault locate/troubleshoot - the process of investigating and detecting the cause of equipment malfunctioning; the act of isolating a fault within a system or unit under test.

**3** Disassemble/assemble - encompasses the step-by-step taking apart (or breakdown) of a spare/functional group coded item to the level of its least componency identified as maintenance significant (i.e., assigned an SMR code) for the level of maintenance under consideration.

**4** Actions - welding, grinding, riveting, straightening, facing, remachining, and/or resurfacing.

d. **Column 4. Maintenance Level.** Column 4 specifies, by the listing of a work time figure in the appropriate subcolumn( the level of maintenance authorized to perform the function listed in column 3. This figure represents the active time required to perform that maintenance function at the indicated level of maintenance. If the number or complexity of the tasks within the listed maintenance function varies at different maintenance levels, appropriate work time figures will be shown for each level. The work time figure represents the average time required to restore an item (assembly, sub-assembly, component, module, end item, or system) to a serviceable condition under typical field operating conditions. This time includes preparation time (including any necessary disassembly/assembly time), troubleshooting/fault location time, and quality assurance/quality control time in addition to the time required to perform the specific tasks identified for the maintenance functions authorized in the maintenance allocation chart. The symbol designations for the various maintenance levels are as follows:

- C .....Operator or crew
- O .....Unit maintenance
- F ..... Direct support maintenance
- H ..... General support maintenance
- L ..... Specialized repair activity (SRA)
- D ..... Overhaul/depot level maintenance

e. **Column 5. Tools and Equipment.** Column 5 specifies, by code, those common tool sets (not individual tools) and special tools, TMDE, and support equipment required to perform the designated function.

f. **Column 6. Remarks.** This column shall, when applicable, contain a letter code, in alphabetic order, which shall be keyed to the remarks contained in Section IV.

**B-4 EXPLANATION OF COLUMNS IN TOOL AND TEST EQUIPMENT REQUIREMENTS, SECTION III.**

a. **Column 1, Reference Code.** The tool and test equipment reference code correlates with a code used in the MAC, Section II, column 5.

b. **Column 2, Maintenance Level.** The lowest level of maintenance authorized to use the tool or test equipment.

c. **Column 3, Nomenclature.** Name or identification of the tool or test equipment.

d. **Column 4, National Stock Number.** The national stock number of the tool or test equipment.

e. **Column 5, Tool Number.** The manufacturer's part number.

**B-5 EXPLANATION OF COLUMNS IN REMARKS, SECTION IV.**

a. **Column 1, Reference Code.** The code recorded in column 6, Section II.

b. **Column 2, Remarks.** This column lists information pertinent to the maintenance function being performed as indicated in the MAC, Section II.

**SECTION II. MAINTENANCE ALLOCATION CHART.**

(1) Group Number	(2) Component/Assembly	(3) Maintenance Function	(4) Maintenance Category					(5) Tools and Equipment	(6) Remarks
			C	O	F	H	D		
00	INTERCONNECTING BOX, TARGET INTERFACE (9353787)	INSPECT		.1					
		REMOVE AND REPLACE		.1				9	
		REPAIR		.1	.2			9,13	A
001	POWER SUPPLY ASSEMBLY (9353789)	REMOVE AND REPLACE		.4				9	
		REPAIR		.2				8,9,10	A
002	CARD HOLDER ASSEMBLY (9353816)	REMOVE AND REPLACE			.3			9	
		REPAIR			.2			9	A
00201	SUPPRESSOR ASSEMBLY (9354186-3)	REMOVE AND REPLACE			.1			9	
		ASSEMBLE			.2			4,7,8,9,10	
003	WIRING HARNESS (9353793)	REMOVE AND REPLACE			1.3			9,13	
		REPAIR			.9			4,7,8,9,10,13	A
004	WIRING HARNESS (9353958)	REMOVE AND REPLACE			.2			9	
		ASSEMBLE			.5			4,7,8,9,10	
005	CABLE ASSEMBLY (9363185)	REMOVE AND REPLACE		.1					
		REPAIR			.6			4,7,8,9,10,11, 12	A
01	INTERCONNECTING BOX, HIGH POWER (9353786)	INSPECT		.1				9	
		REMOVE AND REPLACE REPAIR		.1	.1			9	A
0101	TRANSFORMER ASSEMBLY (9353821)	REMOVE AND REPLACE			.2			9	
		REPAIR			.1			8,9,10	A
0102	CIRCUIT BREAKER ASSEMBLY (9354038-1)	REMOVE AND REPLACE		.2				9	
		ASSEMBLE			.2			4,7,8,9,10	A
0103	WIRING HARNESS (9354132)	REMOVE AND REPLACE		.2				9	
		ASSEMBLE		.2				8,9,10	

(1) Group Number	(2) Component/Assembly	(3) Maintenance Function	(4) Maintenance Category					(5) Tools and Equipment	(6) Remarks
			C	O	F	H	D		
0104	JUMPER ASSEMBLY (9387197-1)	REMOVE AND REPLACE ASSEMBLE			.1			9	
					.1			8,9,10	
0105	JUMPER ASSEMBLY (9387197-2)	REMOVE AND REPLACE ASSEMBLE			.1			9	
					.1			8,9,10	
0106	CABLE ASSEMBLY (9354096-2)	REMOVE AND REPLACE REPAIR	.1						
					.3			4,7,8,9,10	A
0107	CABLE ASSEMBLY (9354098-2)	REMOVE AND REPLACE REPAIR	.1						
					.2			4,7,8,9,10	A
02	INTERCONNECTING BOX, LOW POWER (9341190)	INSPECT REMOVE AND REPLACE REPAIR	.1						
			.1	.6				9	
					.1			9	A
0201	CIRCUIT BREAKER ASSEMBLY (9354038-2)	REMOVE AND REPLACE ASSEMBLE	.2					9	
					.2			4,7,8,9,10	
0202	TRANSFORMER ASSEMBLY (9354036)	REMOVE AND REPLACE REPAIR			.2			9	
					.1			8,9,10	A
0203	WIRING HARNESS (9354132)	REMOVE AND REPLACE ASSEMBLE	.2					9	
			.2					8,9,10	
0204	JUMPER ASSEMBLY (9387197-1)	REMOVE AND REPLACE ASSEMBLE			.1			9	
					.1			8,10	
0205	JUMPER ASSEMBLY (9387197-2)	REMOVE AND REPLACE ASSEMBLE			.1			9	
					.1			8,10	
0206	CABLE ASSEMBLY (9354096-1)	REMOVE AND REPLACE REPAIR	.1						
					.3			4,7,8,9,10	A

**SECTION II. MAINTENANCE ALLOCATION CHART (CONTINUED).**

(1) Group Number	(2) Component/Assembly	(3) Maintenance Function	(4) Maintenance Category					(5) Tools and Equipment	(6) Remarks
			C	O	F	H	D		
0207	CABLE ASSEMBLY (9354098-1)	REMOVE AND REPLACE REPAIR		.1				4,7,8,9,10	A
					.2				
0208	OUTLET ASSEMBLY (12974140)	REMOVE AND REPLACE ASSEMBLE		.2				9	
					.2			4,7,8	

**SECTION III. TOOL AND TEST EQUIPMENT REQUIREMENTS**

**FOR**

**TIU, ICB/HIGH POWER, AND ICB/LOW POWER**

TOOL OR TEST EQUIPMENT REF CODE	MAINTENANCE CATEGORY	NOMENCLATURE	NATIONAL/NATO STOCK NUMBER	TOOL NUMBER
1	C	BRUSH, WIRE	7920-00-044-4857	1182
2	C	GLOVES, RUBBER	4240-01-066-9067	MIL-G-44005S
3	C	GOGGLES, INDUSTRIAL	4240-00-052-3776	A-A-1110
4	F	HEATER, GUN-TYPE, ELECTRIC	4940-01-181-5876	1264T585
5	C	MASK, AIR FILTERING	4240-01-105-8995	11-875-54
6	O	MULTIMETER	6625-01-265-6000	AN/PSM-45A
7	F	SOLDERING AND DESOLDERING SET	3439-00-460-7198	W-TCP-K

TOOL OR TEST EQUIPMENT REF CODE	MAINTENANCE CATEGORY	NOMENCLATURE	NATIONAL/NATO STOCK NUMBER	TOOL NUMBER
8	F	STRIPPERS, WIRE	5110-00-175-8730	13143304
9	O	TOOL KIT, GEN MECHANIC'S AUTOMOTIVE	5180-00-177-7033	SC5180-90-CL-N26
10	F	TOOL, CRIMPER	5120-00-165-3912	11-3284-2
11	F	TOOL, INSERTION/EXTRACTION	5120-00-915-4588	M81969/14-03
12	F	TOOL, INSERTION/EXTRACTION	5120-01-300-0095	M81969/14-11
13	F	WRENCH, TORQUE	5120-00-001-3733	28414

**SECTION IV. REMARKS.**

REFERENCE CODE	REMARKS
A	Repair consists of replacing subassemblies and component parts.





**APPENDIX C**

**UNIT MAINTENANCE**

**COMMON TOOLS AND SUPPLEMENTS**

**AND SPECIAL TOOLS/FIXTURES LIST**

Not Applicable



## APPENDIX D

### EXPENDABLE AND DURABLE ITEMS LIST

#### SECTION I. INTRODUCTION

##### D-1 SCOPE.

This appendix lists expendable and durable items that you will need to operate and maintain the Interconnecting Box, Target Interface (TIU); Interconnecting Box, High Power (ICB/High Power); and Interconnecting Box, Low Power (ICB/Low Power). This listing is for information only and is not authority to requisition the listed items. These items are authorized to you by CTA 50-790, Expendable/Durable Items.

##### D-2 EXPLANATION OF COLUMNS.

- a. **Column (1) - Item Number.** This number is assigned to the entry in the listing.
- b. **Column (2) - Level.** This column identifies the lowest level of maintenance that requires the item.
- c. **Column (3) - National Stock Number.** This is the National stock number assigned to the item and is used to requisition it.
- d. **Column (4) - Item Name, Description, Commercial and Government Entity Code (CAGEC), and Part Number.** This provides the other information you need to identify the item.
- e. **Column (5) - Unit of Measure.** This code shows the physical measurement or count of an item, such as gallon, dozen, gross, etc.

#### SECTION II. EXPENDABLE AND DURABLE ITEMS LIST

(1) ITEM NUMBER	(2) LEVEL	(3) NATIONAL STOCK NUMBER	(4) ITEM NAME, DESCRIPTION CAGEC, PART NUMBER	(5) U/M
1	F	8040-00-832-6173	Adhesive 04963 (EC-1357-5 OZ)	OZ
1a	O	8040-01-281-2729	Adhesive 81349 (M46050-13-2-50)	EA
2	O	9150-00-965-2408	Grease 19200 (9362987)	OZ
3	O	8010-00-297-2124	Enamel 96906 (MS35530-2)	GL

## SECTION II. EXPENDABLE AND DURABLE ITEMS LIST (CONTINUED).

(1) ITEM NUMBER	(2) LEVEL	(3) NATIONAL STOCK NUMBER	(4) ITEM NAME, DESCRIPTION CAGEC, PART NUMBER	(5) U/M
4	O	5350-00-186-8858	Paper, Abrasive 58536 (A-A-1049)	PG
5	O	8010-00-899-8825	Primer, Coating 83421 (8010-00-899-8825)	PT
6	C	7920-00-205-3570	Rag, Wiping 58536 (A-A-2522)	BE
7	F	8030-00-823-7917	Sealing Compound 05972 (08431)	CC
8	F	8030-01-025-1692	Sealing Compound 05972 (242-41)	OZ
9	O	8030-01-044-5527	Sealing Compound 05972 (07331)	OZ
10	F	8040-00-843-0802	Adhesive 19200 (9363004)	EA
11	F	3439-00-108-7578	Solder, Rosin Core 81348 (SN63WRMAP3)	OZ
12	O	6850-00-110-4498	Solvent, Dry Cleaning 81348 (PD680)	PT
13	F	6920-01-235-0250	Tape, Filament 19200 (11784588)	EA
14	O	8040-01-303-3082	Adhesive 05972 40104	GM

## APPENDIX E

### TORQUE LIMITS

#### SECTION I. INTRODUCTION.

##### E-1 GENERAL.

This appendix contains the torque standards for specific type and size of hardware. It defines the different types of bolts by grade.

#### SECTION II. TORQUE TABLE.

HOW TO USE TORQUE TABLE:

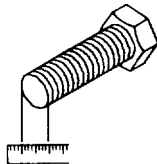

a. Measure the diameter of the screw you are installing.

c. Under the SIZE, look down the left-hand column until you find the diameter of the screw you are installing. There will usually be two lines beginning with the same size.)

d. In the second column under SIZE find the number of threads per inch that matches the number of threads you counted in step 2. (Not required for metric screws.)

##### CAPSCREW HEAD MARKINGS

Manufacturer's marks may vary. These are all SAE Grade 5 (3-line).

Metric screws are of three grades: 8.8, 10.9, and 12.9. Grades & Manufacturer's marks appear on the screw head

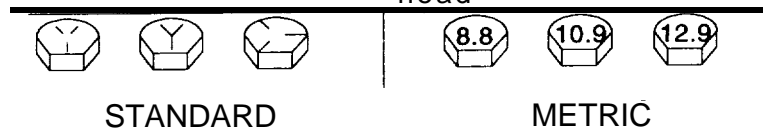

STANDARD

METRIC

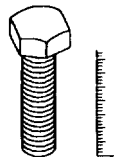

b. Count the number of threads per inch or use a pitch gage.

e. To find the grade screw you are installing, match the markings on the head to the correct picture of CAPSCREW HEAD MARKINGS on the torque table.

f. Look down the column under the picture you found in step 5 until you find the torque limit (LB-IN./FT or N.M) for the diameter and threads per inch of the screw you are installing.

TORQUE LIMITS FOR DRY FASTENERS

CAPSCREW HEAD MARKINGS			TORQUE							
 <p>Manufacturer's marks may vary. These are all SAE Grade 5 (3-line).</p>			SAE GRADE NO. 2		SAE GRADE NO. 5		SAE GRADE NO. 6 OR 7		SAE GRADE NO. 8	
			Dia. Inches	Threads Per Inch	Millimeters	Pound Newton-Feet	Newton-Meters	Pound Newton-Feet	Newton-Meters	Pound Newton-Feet
1/4	20	6.35	5	7	7	8	10	14	12	16
1/4	28	6.35	6	9	9	10	12	16	14	19
5/16	18	7.94	11	15	15	17	21	28	25	34
5/16	24	7.94	12	16	16	19	24	22	25	34

TORQUE LIMITS FOR WET FASTENERS

CAPSCREW HEAD MARKINGS			TORQUE							
 <p>Manufacturer's marks may vary. These are all SAE Grade 5 (3-line).</p>			SAE GRADE NO. 2		SAE GRADE NO. 5		SAE GRADE NO. 6 OR 7		SAE GRADE NO. 8	
			Dia. Inches	Threads Per Inch	Millimeters	Pound Newton-Feet	Newton-Meters	Pound Newton-Feet	Newton-Meters	Pound Newton-Feet
1/4	20	6.35	4	6	6	8	8	11	9	12
1/4	28	6.35	5	7	7	9	9	12	10	14
5/16	18	7.94	8	11	3	18	16	22	18	24
5/16	24	7.94	9	12	14	19	18	24	20	27

## TIGHTENING METAL FASTENERS

When torquing a fastener, select a wrench whose range fits the required torque value. A torque wrench is most accurate from 25% to 75% of its stated range. A wrench with a stated range of 0 to 100 will be most accurate from 25 to 75 Pound-Feet. The accuracy or readings will decrease as you approach 0 Pound-Feet or 100 Pound-Feet. The following ranges are based on this principle.

### TORQUE RANGES

STATED RANGE		MOST EFFECTIVE RANGE	
0-200	lb-ft	4-13	lb-ft
0-600	lb-ft	50-450	lb-ft
0-170	lb-ft	44-131	lb-ft
15-75	lb-ft	30-60	lb-ft

FASTENER SIZE AND THREAD PATTERN

Threaded fasteners are categorized according to diameter of the fastener shank. Thread styles are divided into broad groups, the two most common being coarse (Unified Coarse-UNC) and fine (Unified Fine-UNF). These groups are defined by the number of threads per inch on the bolt shanks. In addition, threads are categorized by thread class, which is a measure of the degree of fit between the threads of the bolt or screw (external threads) and the threads of the attaching nut or tapped hole (internal threads). The most common thread class for bolts and screws is Class 2.

THREAD CLASSES AND DESCRIPTION

EXTERNAL	INTERNAL	FIT
1A	1B	LOOSE FIT
2A	2B	MEDIUM FIT
3A	3B	CLOSE FIT

Thread patterns are designated as follows:

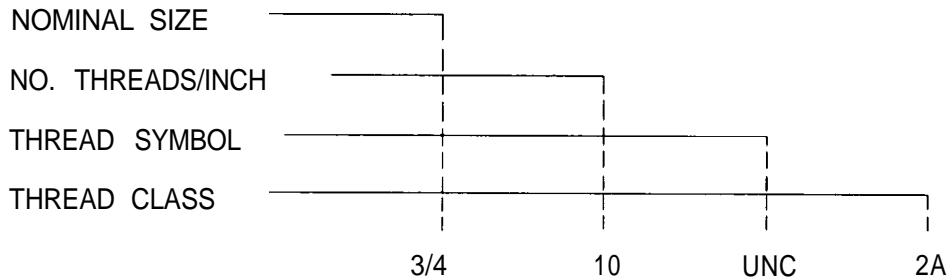

NOTE: Unless followed with -LH (eg, 3/4-10UNC-2a-LH), threads are right-hand.

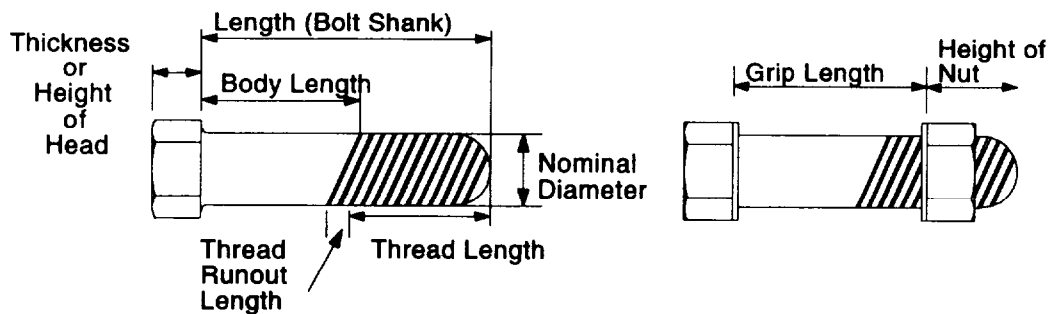



## FASTENER GRADE

In addition to being classified by thread type, threaded fasteners are also classified by material. The most familiar fastener classification system is the SAE grading system.

### SAE SCREW AND BOLT MARKINGS

SCREWS	BOLTS
SAE GRADE 2 NO MARKING	SAE GRADE 6 4 RADIAL DASHES 90° APART
SAE GRADE 3 2 RADIAL DASHES 180° APART	SAE GRADE 7 5 RADIAL DASHES 72° APART
SAE GRADE 5 3 RADIAL DASHES 120° APART	SAE GRADE 8 6 RADIAL DASHES 60° APART
	GRADE 8.2 6 RADIAL DASHES 30° APART

NOTE  
Torque values for Grade 8.2 bolts  
are the same as for Grade 8.

### MARKINGS ON HEX LOCKNUTS

GRADE A - No Marks	GRADE A - No Mark
GRADE B - 3 Marks	GRADE B - Letter B
GRADE C - 6 Marks	GRADE C - Letter C
GRADE A - No Notches	
GRADE B - One Notch	
GRADE C - Two Notches	

TORQUE VALUE GUIDE

SCREW DIAMETER	TORQUE NO DASHES (SAE GRADE 2)	TORQUE 3 DASHES (SAE GRADE 5)	TORQUE 6 DASHES (SAE GRADE 8)	SOCKET SIZE
1/4-20 UNC	3-5 ft-lb (4-7 N.m)	6-8 ft-lb (8-11 N.m)	10-12 ft-lb (14-16 N.m)	7/16
1/4-28 UNF	4-6 ft-lb (5-8 N.m)	8-10 ft-lb (11-14 N.m)	9-14 ft-lb (12-19 N.m)	7/16
5/16-18 UNC	7-11 ft-lb (9-15 N.m)	13-17 ft-lb (18-23 N.m)	19-24 ft-lb (26-33 N.m)	1/2
5/16-24 UNF	7-11 ft-lb (9-15 N.m)	14-19 ft-lb (19-26 N.m)	23-28 ft-lb (31-38 N.m)	1/2
3/8-16 UNC	14-18 ft-lb (19-24 N.m)	26-31 ft-lb (35-32 N.m)	39-44 ft-lb (53-60 N.m)	9/16
3/8-24 UNF	15-19 ft-lb (20-26 N.m)	30-35 ft-lb (41-47 N.m)	46-51 ft-lb (62-69 N.m)	9/16
7/16-14 UNC	23-28 ft-lb (31-38 N.m)	44-49 ft-lb (60-66 N.m)	65-70 ft-lb (88-95 N.m)	5/8
7/16-20 UNF	23-28 ft-lb (31-38 N.m)	44-54 ft-lb (60-73 N.m)	69-79 ft-lb (94-107 N.m)	5/8
1/2-13 UNC	32-37 ft-lb (43-50 N.m)	65-75 ft-lb (88-102 N.m)	95-105 ft-lb (129-142 N.m)	3/4
1/2-20 UNF	34-41 ft-lb (46-56 N.m)	73-83 ft-lb (99-113 N.m)	113-123 ft-lb (153-167 N.m)	3/4
9/16-12 UNC	46-56 ft-lb (62-76 N.m)	100-110 ft-lb (136-149 N.m)	145-155 ft-lb (197-210 N.m)	13/16
9/16-18 UNF	47-57 ft-lb (64-77 N.m)	107-117 ft-lb (145-159 N.m)	165-175 ft-lb (224-237 N.m)	13/16
5/8-11 UNC	62-72 ft-lb (84-98 N.m)	140-150 ft-lb (190-203 N.m)	200-210 ft-lb (271-285 N.m)	15/16
5/8-18 UNF	67-77 ft-lb (91-104 N.m)	153-163 ft-lb (207-221 N.m)	235-245 ft-lb (319-332 N.m)	15/16
3/4-10 UNC	106-116 ft-lb (144-157 N.m)	260-270 ft-lb (353-366 N.m)	365-375 ft-lb (495-508 N.m)	1-1/4
3/4-16 UNF	115-125 ft-lb (156-169 N.m)	268-278 ft-lb (363-377 N.m)	417-427 ft-lb (565-579 N.m)	1-1/4
7/8-9 UNC	165-175 ft-lb (224-237 N.m)	385-395 ft-lb (522-536 N.m)	595-605 ft-lb (807-820 N.m)	1-5/16
7/8-14 UNF	178-188 ft-lb (241-255 N.m)	424-434 ft-lb (575-588 N.m)	663-673 ft-lb (899-912 N.m)	1-5/16
1-8 UNC	251-261 ft-lb (340-354 N.m)	580-590 ft-lb (786-800 N.m)	900-910 ft-lb (1220-1234 N.m)	1-1/2
1-14 UNF	255-265 ft-lb (346-359 N.m)	585-634 ft-lb (793-860 N.m)	943-993 ft-lb (1279-1346 N.m)	1-1/2
1-1/4-7 UNC	451-461 ft-lb (611-625 N.m)	1070-1120 ft-lb (1451-1518 N.m)	1767-1817 ft-lb (2396-2463 N.m)	1-7/8
1-1/4-12 UNF	488-498 ft-lb (662-675 N.m)	1211-1261 ft-lb (1642-1710 N.m)	1963-2013 ft-lb (2661-2729 N.m)	1-7/8
1-1/2-6 UNC	727-737 ft-lb (986-999 N.m)	1899-1949 ft-lb (2575-2642 N.m)	3111-3161 ft-lb (4218-4286 N.m)	2-1/4
1-1/2-12 UNF	816-826 ft-lb (1106-1120 N.m)	2144-2194 ft-lb (2907-2975 N.m)	3506-3556 ft-lb (4753-4821 N.m)	2-1/4

By Order of the Secretary of the Army:

DENNIS J. REIMER  
General, United States Army  
Chief of Staff

Official:

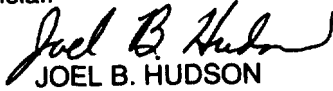

JOEL B. HUDSON

Administrative Assistant to the  
Secretary of the Army  
03279

**DISTRIBUTION:** To be distributed in accordance with the initial distribution number (IDN) 372427, requirements for TM 9-6920-742-14-4.



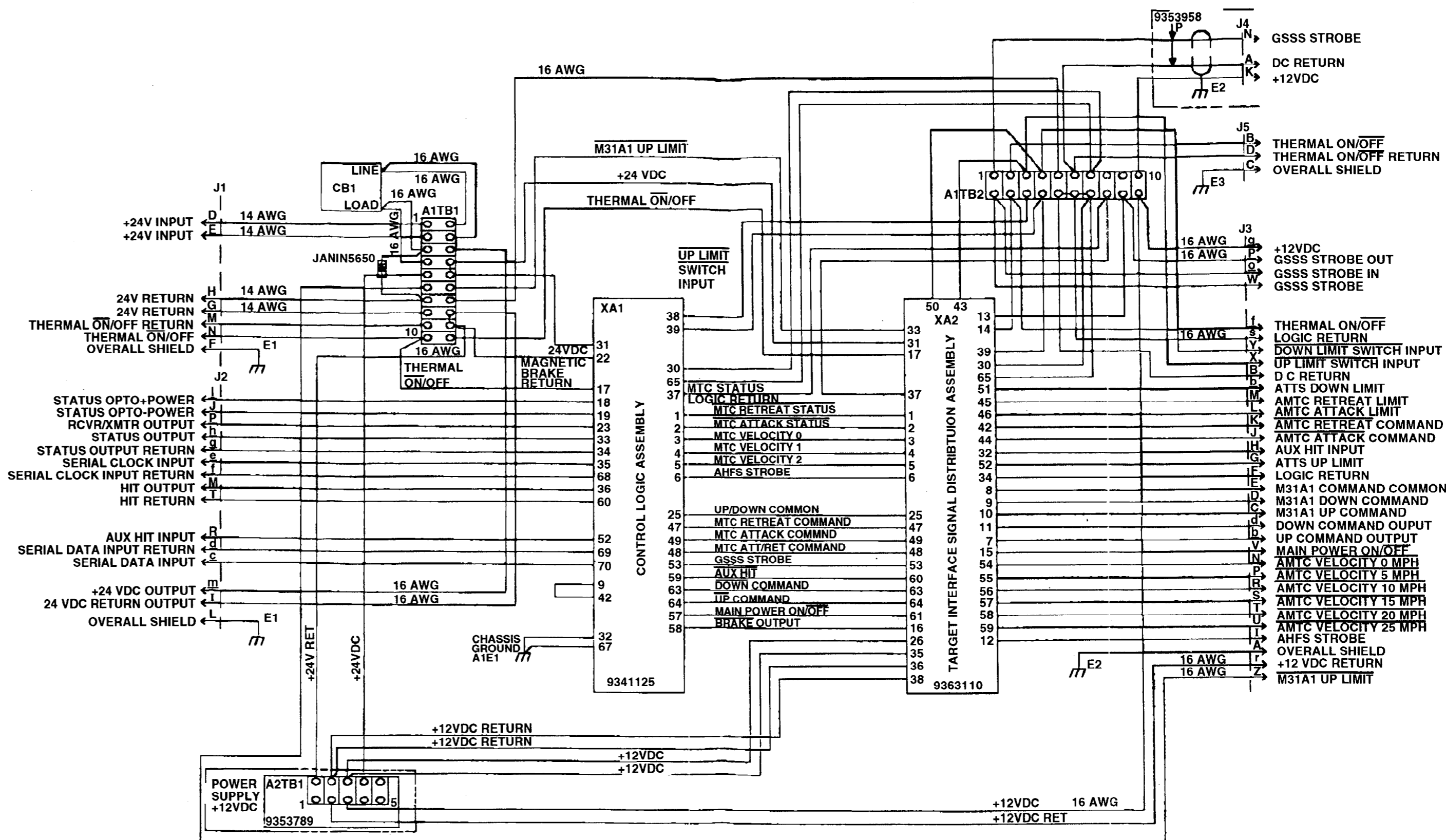

FO-1. TIU Wiring Diagram

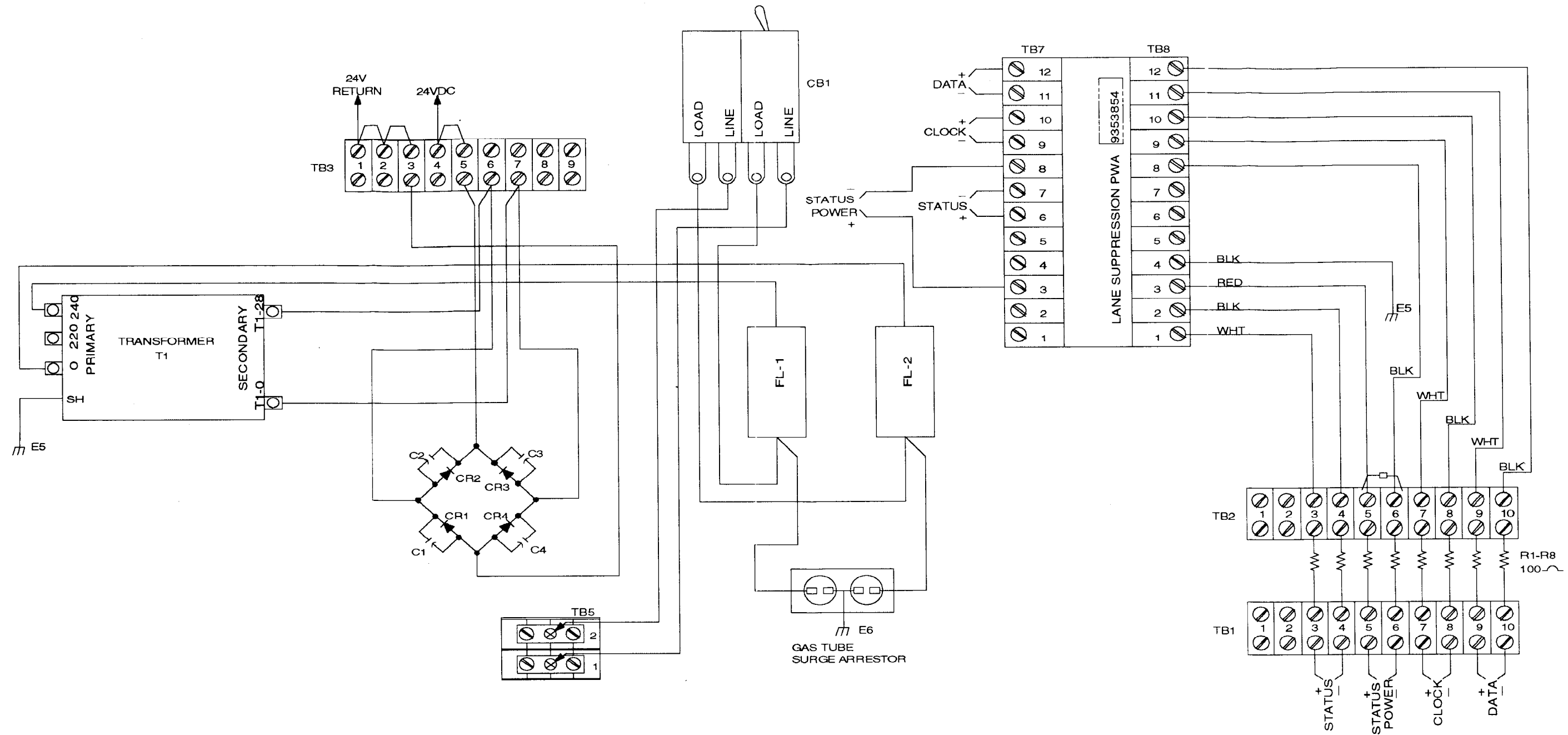

FO-2. ICB/High Power Wiring Diagram

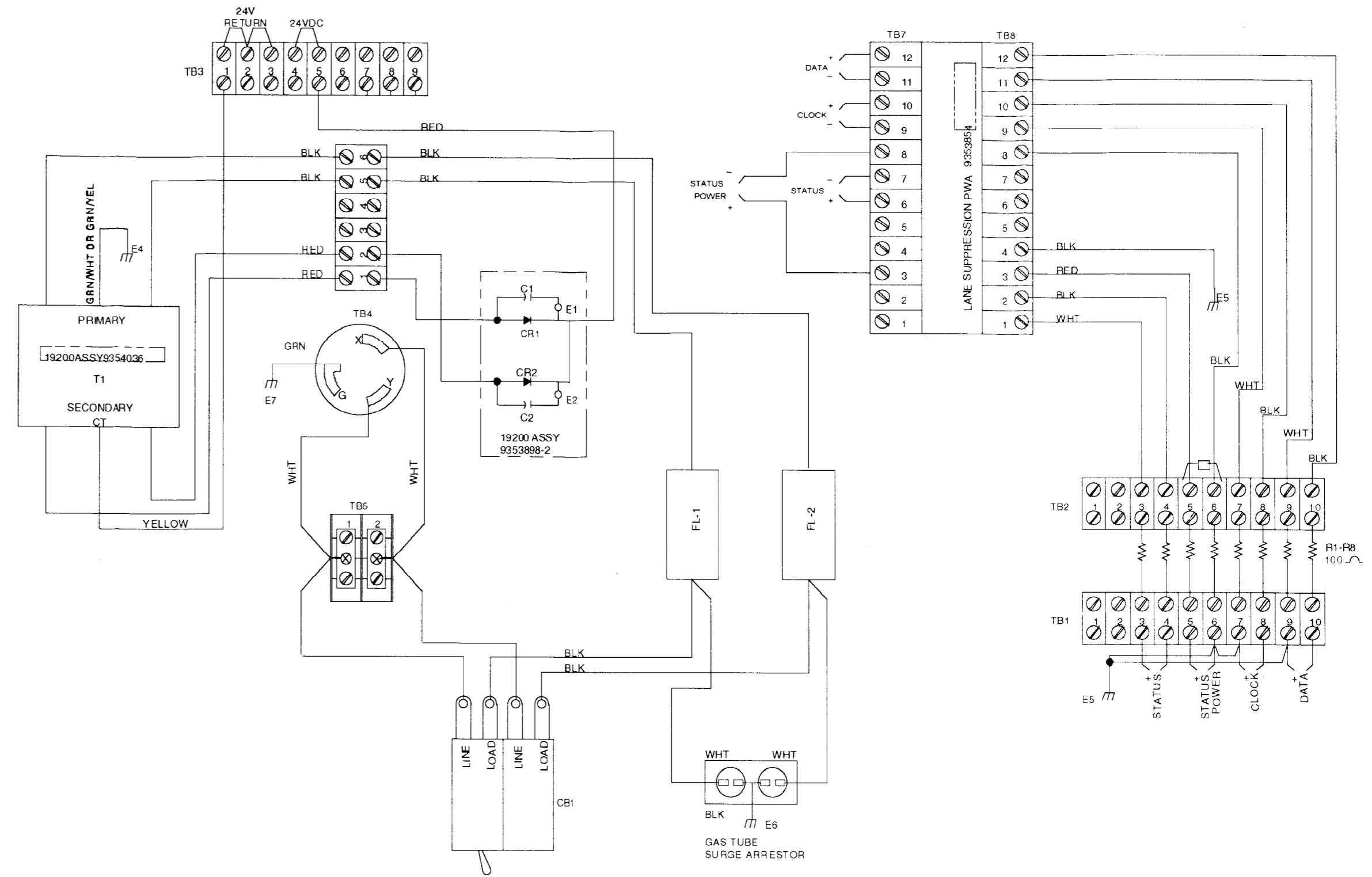

FO-3. ICB/low Power Wiring Diagram

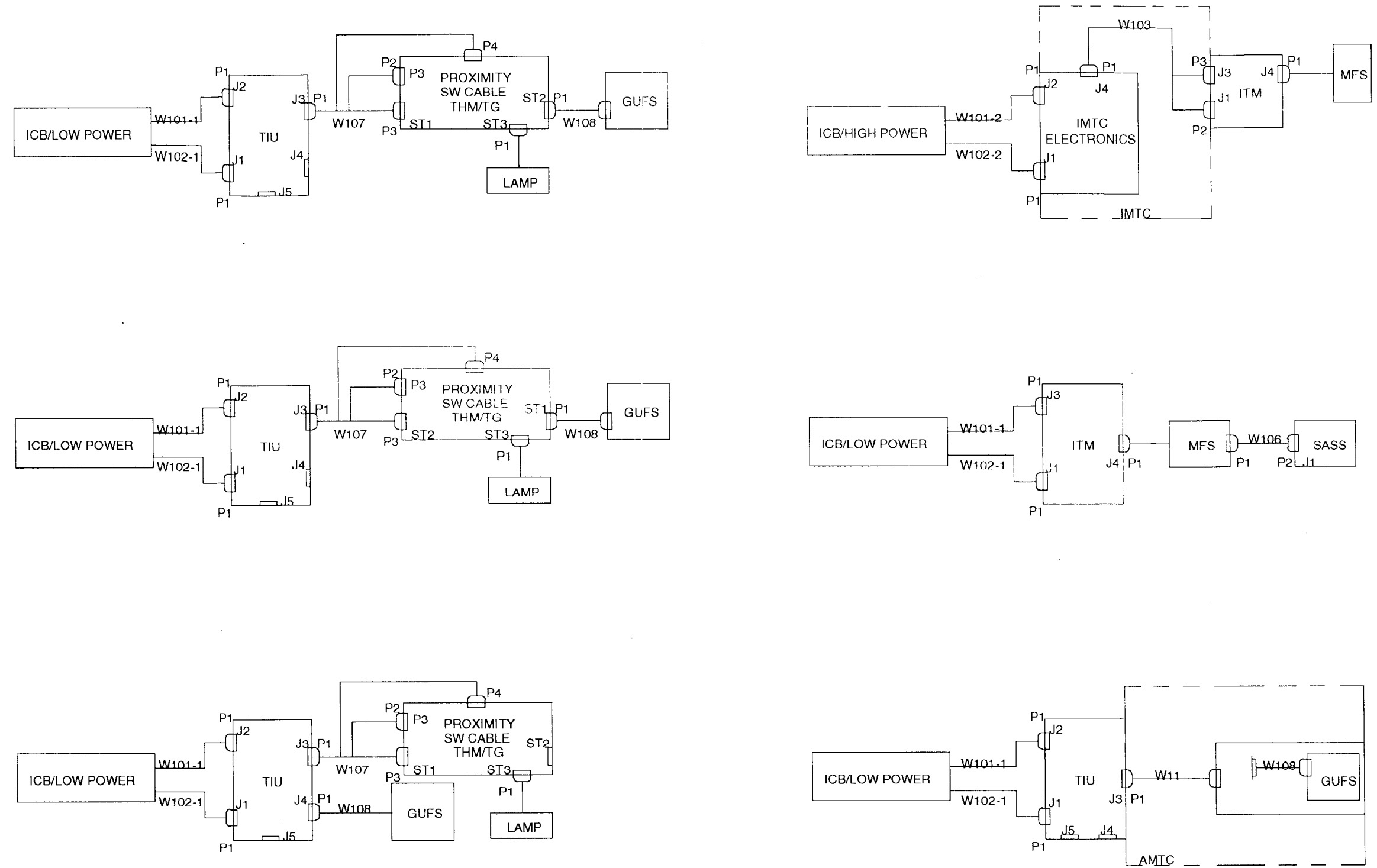

FO-4. System Wiring Diagram.



RECOMMENDED CHANGES TO EQUIPMENT TECHNICAL PUBLICATIONS



## SOMETHING WRONG WITH THIS PUBLICATION?

**THEN... JOT DOWN THE DOPE ABOUT IT ON THIS FORM. CAREFULLY TEAR IT OUT, FOLD IT AND DROP IT IN THE MAIL!**

**FROM: (PRINT YOUR UNIT'S COMPLETE ADDRESS)**  
Your mailing address

**DATE SENT**  
Date you filled out this form

<b>PUBLICATION NUMBER</b> TM 9-6920-742-14-4	<b>PUBLICATION DATE</b> 13 Feb 97	<b>PUBLICATION TITLE</b> ERETS Interconnecting Boxes
---	--------------------------------------	---

BE EXACT. PIN-POINT WHERE IT IS				IN THIS SPACE TELL WHAT IS WRONG AND WHAT SHOULD BE DONE ABOUT IT:
PAGE NO	PARA-GRAPH	FIGURE NO	TABLE NO	
1-4	1-5d (7)			At the end of subparagraph (7) add:  "See TM 43-0139."

SAMPLE

<b>PRINTED NAME, GRADE OR TITLE AND TELEPHONE NUMBER</b> Your name	<b>SIGN HERE</b> Your signature
---	------------------------------------



RECOMMENDED CHANGES TO EQUIPMENT TECHNICAL PUBLICATIONS



THEN JOT DOWN THE DOPE ABOUT IT ON THIS FORM. CAREFULLY TEAR IT OUT, FOLD IT AND DROP IT IN THE MAIL.

**SOMETHING WRONG WITH THIS PUBLICATION?**

FROM (PRINT YOUR UNIT'S COMPLETE ADDRESS)

DATE SENT

PUBLICATION NUMBER

TM 9-6920-742-14-4

PUBLICATION DATE

13 Feb 97

PUBLICATION TITLE

ERETS Interconnecting Boxes

BE EXACT PIN-POINT WHERE IT IS

PAGE NO

PARA-GRAPH

FIGURE NO

TABLE NO

IN THIS SPACE TELL WHAT IS WRONG AND WHAT SHOULD BE DONE ABOUT IT:

TEAR ALONG PERFORATED LINE

PRINTED NAME GRADE OR TITLE AND TELEPHONE NUMBER

SIGN HERE

DA FORM 2028-2  
1 JUL 79

PREVIOUS EDITIONS ARE OBSOLETE  
AMSMC OP-103-85

P.S. IF YOUR OUTFIT WANTS TO KNOW ABOUT YOUR RECOMMENDATION MAKE A CARBON COPY OF THIS AND GIVE IT TO YOUR HEADQUARTERS

FILL IN YOUR  
UNITS ADDRESS



DEPARTMENT OF THE ARMY

OFFICIAL BUSINESS



NO POSTAGE  
NECESSARY  
IF MAILED  
IN THE  
UNITED STATES

**BUSINESS REPLY MAIL**  
FIRST CLASS      PERMIT NO. 82      ROCK ISLAND IL

POSTAGE WILL BE PAID BY ROCK ISLAND ARSENAL



Director  
Armament and Chemical Acquisition  
and Logistics Activity  
ATTN: AMSTA-AC-NML  
Rock Island, IL 61201-9948

TEAR ALONG PERFORATED LINE





FILL IN YOUR  
UNITS ADDRESS



DEPARTMENT OF THE ARMY

OFFICIAL BUSINESS



NO POSTAGE  
NECESSARY  
IF MAILED  
IN THE  
UNITED STATES

**BUSINESS REPLY MAIL**  
FIRST CLASS      PERMIT NO. 82      ROCK ISLAND IL

POSTAGE WILL BE PAID BY ROCK ISLAND ARSENAL

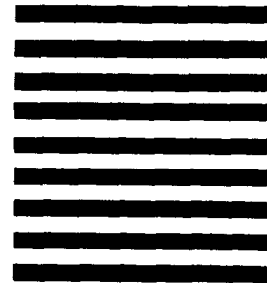

**Director  
Armament and Chemical Acquisition  
and Logistics Activity  
ATTN: AMSTA-AC-NML  
Rock Island, IL 61201-9948**



TEAR ALONG PERFORATED LINE



FILL IN YOUR  
UNITS ADDRESS



DEPARTMENT OF THE ARMY

OFFICIAL BUSINESS



NO POSTAGE  
NECESSARY  
IF MAILED  
IN THE  
UNITED STATES

**BUSINESS REPLY MAIL**  
FIRST CLASS      PERMIT NO. 82      ROCK ISLAND IL

POSTAGE WILL BE PAID BY ROCK ISLAND ARSENAL



Director  
Armament and Chemical Acquisition  
and Logistics Activity  
ATTN: AMSTA-AC-NML  
Rock Island, IL 61201-9948

TEAR ALONG PERFORATED LINE











